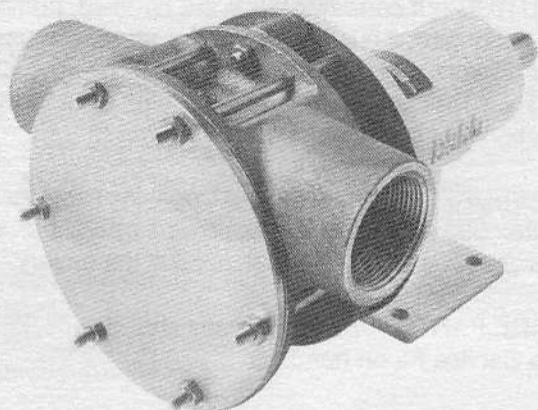

**JABSCO**<sup>®</sup>**Models: 340-0001  
347-0001**

Model 340-0001

## SELF-PRIMING PUMPS FEATURES

<b>Body:</b>	316 Stainless Steel
<b>Impeller:</b>	Neoprene
<b>Seal:</b>	Carbon-Stainless Steel Face Type
<b>Shaft:</b>	316 Stainless Steel
<b>Bearings:</b>	Sealed, Pre-lubricated Ball Bearings
<b>Pedestal:</b>	Model 340-0001 - 316 Stainless Steel Model 347-0001 - Cast Iron, Painted
<b>Ports:</b>	1-1/2" Internal Pipe Thread
<b>Weight:</b>	25 lb (approx) (11,4 kg)

MODEL: 340-0001 &amp; 347-0001

## TYPICAL APPLICATIONS

**INDUSTRIAL:** Circulating and transferring corrosive liquids. Returning spilled liquids to process. Transferring foaming solutions with entrained air, such as soaps and detergents. Industrial and process filling systems. Ideal for sampling and pilot plant installations. Circulating abrasive and non-abrasive slurries (low speed). Transferring inks, dyes, sizes, starches, etc. Circulating through various type filters; pumping solids in suspension; transferring viscous materials such as honey, gelatins and toothpaste.

**PHARMACEUTICAL:** Processing medicines, lotions, preparations. Filtering thick and thin liquids such as cosmetic lotions and pharmaceuticals.

**PAPER PROCESSING:** Transferring and applying starches, sizes, etc. Circulating and processing wood pulp slurries (pilot and test plant operation). Freeness testing of wood pulp slurries (low speed).

Applying and transferring coatings and processing. Removing sulphide solutions from process.

**FOOD, BEVERAGE & DAIRY:** Transfer brines, vinegar, syrups during processing. Pumping beet sugars and cane pulp liquors. Removal of brewery slop and distillery wort from process. Transferring liquids containing solids in suspension such as chopped tomatoes, nuts, etc. Dispensing fruit juices, punch, cider, etc. Processing viscous materials such as peanut butter, mayonnaise,

ketchup, honey, gelatins (low speed). Pumping whiskey, wine and rums. Returning spilled liquids to process. Transferring citric acid and flavorings in soft drink processing.

**AGRICULTURAL:** Transferring liquid fertilizer components (Phosphoric Acid). Applying liquid fertilizers driven by tractor power take-off. As a transfer pump at liquid fertilizer distributing stations.

**CHEMICAL:** Circulating and transferring various chemicals such as alcohols, ammonia, barium, copper sulphate, cyanide solutions, glycerine, nickel chloride, silver nitrate, sodium bicarbonate, sodium thiosulphate, etc. Circulating and transferring various acids such as boric, carbonic, citric, phosphoric, tartaric, etc. Transferring and processing natural latex (low speed). Circulating photo processing solutions including fix and developer. Recirculating through electro-plating filters. Circulating and transferring alkaline solutions.

See the Jabsco Pump "Chemical Resistance Table" in the Industrial Catalog which has been prepared to help you select the most suitable impeller and pump material.

**NOTE:** Food, beverage, dairy and pharmaceutical applications may require sanitary pumps. Ref. ITT Jabsco Pureflo<sup>®</sup> Pump Series.

## OPERATING INSTRUCTIONS

1. **INSTALLATION** --- Pump may be mounted in any position. Intake and discharge ports are determined by the direction of shaft rotation (refer to Dimensional Drawing). Before installing, turn the pump shaft in the direction of the operating rotation.

2. **DRIVE** --- Belt or direct with flexible coupling.  
**BELT DRIVE** -- Overtight belt load will reduce pump bearing life.  
**DIRECT DRIVE** -- Clearance should be left between drive shaft and pump shaft when installing coupling. Always mount pump and align pump and drive shaft before tightening the coupling set screw.

3. **SPEEDS** --- 100 RPM to the maximum shown in the performance table. Consult the factory for operation at speeds above those shown. For longer pump life, operate at the lowest possible speeds.

4. **SELF-PRIMING** --- Primes at low or high speeds. For vertical dry suction lift of 10 feet, a minimum of 800 RPM is required. Pump will produce suction lifts up to 22 feet

when wetted. **BE SURE SUCTION LINES ARE AIR-TIGHT OR PUMP WILL NOT SELF-PRIME.**

5. **DISCHARGE LINE** -- When transferring liquids further than 25 ft., use 2" discharge line.

6. **RUNNING DRY** -- Unit depends on liquid pumped for lubrication. **DO NOT RUN DRY** for more than 30 seconds. Lack of liquid will burn the impeller.

7. **CAUTION** -- If corrosive fluids are handled, pump life will be prolonged, if flushed with water after each use or after each work day. Consult Jabsco Pump Chemical Resistance Table in the Industrial Catalog. For further information, contact factory.

8. **PRESSURES** -- Consult Head Capacity Table for recommended maximum for continuous operation. If pressures exceed those shown, consult the factory.

9. **SPARE PARTS** -- To avoid costly shut-downs, keep a Jabsco Service Kit on hand.

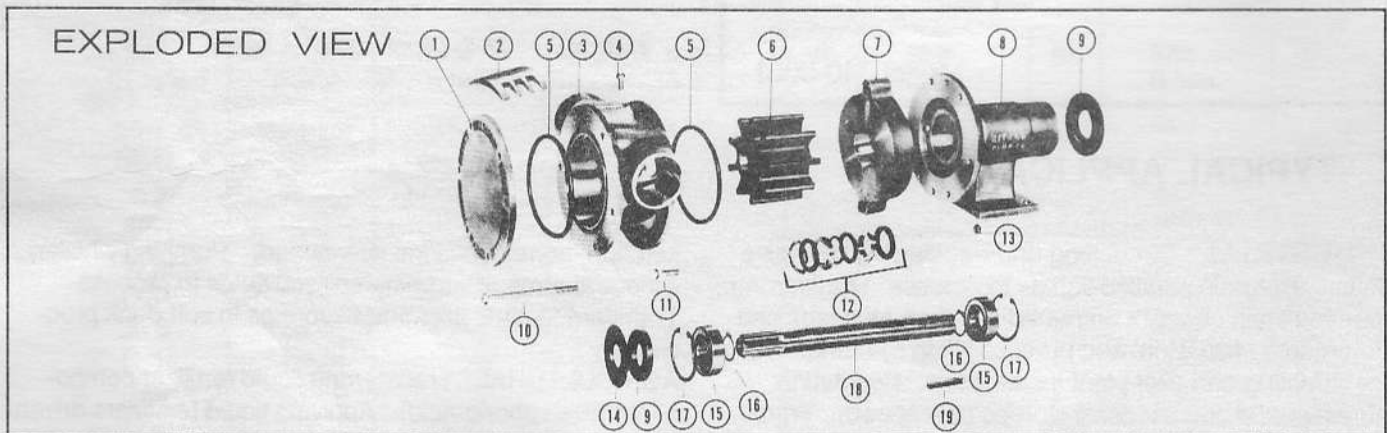

### PART LIST

Key	Description	Part Number	Qty. Req.
1	End Cover	313-0000	1
2	Cam	604-0000	1
3	Body	292-0000	1
4	Screw (cam)	91025-0010	2
5*	O-ring	92000-0300	1
6*	Impeller (standard) Impeller (SS insert)	331-0001 18018-0001	1
7	Seal Housing	687-0000	1
8	Pedestal Stainless Steel Model 340-0001 Pedestal Cast Iron-Painted Model 347-0001	290-0000 649-0000	1
9	Bearing Seal	449-0000	1
10	Bolts	91095-0140	6

Key	Description	Part Number	Qty. Req.
11	Bolts	91094-0040	2
12*	Seal Assembly	1817-0000	1
13	Nut	91085-0050	8
14	Slinger	3181-0000	1
15	Ball Bearing	92600-0020	2
16	Retaining Ring	91700-0980	2
17	Retaining Ring	91701-0260	2
18	Shaft	680-0000	1
19	Key	91402-0110	1
Not Shown	Service Kit, Neoprene	90007-0001	

\*Parts supplied in Service Kit

## SERVICE INSTRUCTIONS

### DISASSEMBLY

1. Remove end cover nuts, long bolts (6), end cover and O-ring gasket from body.
2. Remove impeller.
3. Remove nuts and short bolts (2) holding body and seal housing to pedestal.
4. Remove body, seal housing and O-ring gasket from body.
5. Seal removal:
  - a. Seal will be removed when the housing is removed.
  - b. Seal seat and gasket will remain in the seal housing while the other parts drop free.
  - c. Remove seal seat and gasket from seal housing.
6. Loosen cam screw and remove cam. Clean off sealant.
7. Remove slinger from shaft.
8. Using extreme care *not to mar the pedestal bore*, insert screwdriver between O.D. of inner seal and pedestal bore and pry out the seal. Repeat for outboard seal.
9. Remove inboard and outboard retaining rings from pedestal.
10. Tap drive end of shaft lightly with a soft nosed mallet and remove shaft and bearing assembly.
11. Remove retaining ring from shaft groove behind outboard bearing and slide along shaft towards inboard bearing and supporting outboard bearing inner race, press shaft through bearing from keyway end.
12. Remove inboard and outboard retaining rings from shaft.
13. Supporting inboard bearing inner race, press shaft through bearing from keyway end.  
(do not press bearing over shaft splines.)

NOTE: Inspect all parts for wear or damage and replace if necessary.

### ASSEMBLY

1. Supporting inner race of bearing, press pump drive (keyway) end of shaft through inboard bearing and beyond second retaining ring groove until groove is visible. Lubricate shaft with oil to ease assembly.
2. Install inboard retaining ring in shaft groove and press shaft from opposite end until retaining ring seats lightly against the bearing.
3. Install retaining ring in outboard retaining ring groove.
4. Oil shaft and supporting inner race of bearing, press shaft into bearing (in the same manner as Step #1) until it seats lightly against the retaining ring.
5. Install inboard retaining ring in pedestal.
6. Lubricate O. D. of bearing with a light film of oil and install shaft and bearing assembly (splined end first) from outboard end of pedestal. Use care to keep bearings aligned with bore.
7. Install outboard retaining ring in pedestal.
8. Pack area between seal and bearing (inboard and outboard) with water pump grease. Lubricate seal lip and O.D., and press bearing seals into pedestal. Seal lip faces away from the bearings.
9. Install slinger on shaft, leaving approximately 1/16" between inboard seal and slinger.
10. Install seal seat and gasket assembly in seal housing until it bottoms with gasket inward. Moisten gasket O.D. with water or petroleum jelly to ease assembly.
11. Assemble seal housing and body with O-ring gasket in groove to pedestal with two short bolts and hex nuts. Top bolt is installed from pump drive end and bottom bolt is installed from the body end.
12. Apply a thin coat of sealant to cam screw threads and top side of cam and install in body.
13. Position ferrule and carbon ring assembly on shaft with carbon against the seal seat. Install marcel washer on shaft and down against rubber washer cemented to the ferrule.
14. Lubricate impeller bore with water or petroleum jelly and install impeller with a rotary motion until the splines engage and then push into bore.
15. Install O-ring gasket in body.
16. Install long bolts through assembly from the pump drive end.
17. Install end cover and secure with hex nuts.

## DIMENSIONAL DRAWING

inches (millimetres)

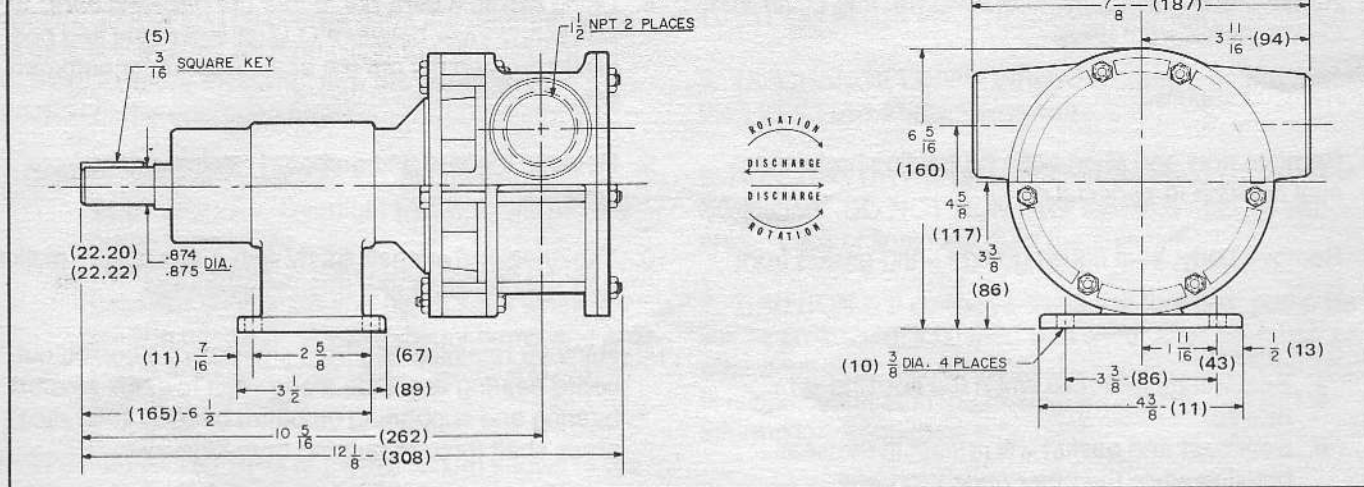

## CAPACITY TABLE

MODELS 340-0001 & 347-0001

TOTAL HEAD		500 RPM		870 RPM		1160 RPM		1750 RPM	
P.S.I. (kg/sq cm)	Ft. of Water (metre)	GPM (L/min)	HP	GPM (L/min.)	HP	GPM (L/min.)	HP	GPM (L/min.)	HP
4.3 (0,3)	10 (3,0)	15 (56,8)	1/2	27,0 (102,2)	3/4	36.3 (137,4)	3/4	54.7 (207,0)	1 1/2
8.7 (0,6)	20 (6,1)	13.7 (51,8)	1/2	25.5 (96,5)	3/4	34.8 (131,7)	3/4	52.7 (199,5)	1 1/2
17.3 (1,2)	40 (12,2)	10.8 (40,9)	1/2	21.8 (82,5)	1	31.5 (119,2)	1	47.2 (178,7)	2
26.0 (1,8)	60 (18,3)			16.8 (63,6)	1	27.0 (102,2)	1 1/2	40.5 (153,3)	2
34.6 (2,4)	80 (24,4)							33.0 (124,9)	3

Progressively longer life may be expected as operating speeds and pressures are reduced. Use high starting torque motor. For operations at speeds not shown, contact factory for application engineering assistance. Table shows approximate head flow for new pump in U. S. Gallons, and metric equivalents.

### ITT JABSCO

A Unit of ITT Corporation  
1485 Dale Way, P.O. Box 2158  
Costa Mesa, CA 92628-2158  
Telephone: (714) 545-8251