

**JABSCO**<sup>®</sup>

## Models 30560-0XXX 30560-1XXX

Models 30560-0XXX / 30560-1XXX

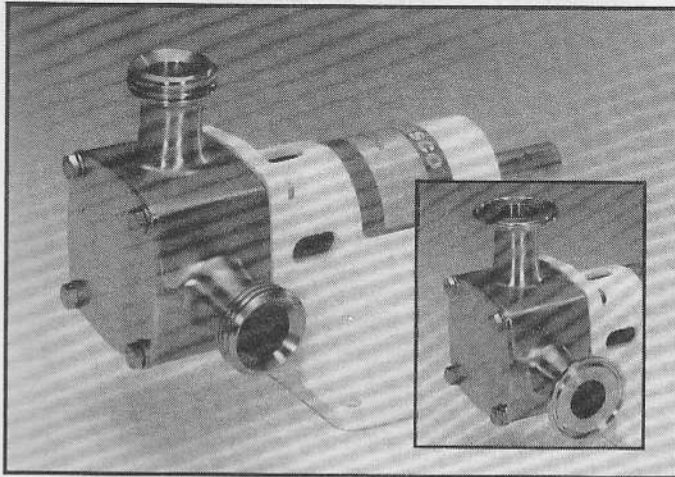

### SELF-PRIMING PUMPS

#### FEATURES

**Pump Type:** Pedestal Pump  
**Body:** 316 Stainless Steel  
**Impeller:** Neoprene  
**Shaft Seal:** Mechanical; Carbon-on-Ceramic or Tungsten Carbide; Nitrile  
**Ports:** 1" ACME Threads with Bevel Seat or Clamp Type  
**Shaft:** 316 Stainless Steel  
**Weight:** 8.5 lb (3,9kg) Approx.

#### APPLICATIONS

**DAIRY:** Transfer and processing of raw milk, cream, milk whey, buttermilk, condensed milk.

**FOODS:** Processing of eggs, sugar liquors, brines, catsup, chocolate, glaze, gelatin, honey, jams, jellies, mayonnaise, molasses, mustard, pickle relish, vinegar, water, yeast slurries, syrups, liquids containing solids in suspension such as chopped tomatoes, nuts, peanut butter.

**BEVERAGE:** Circulating and transferring alcohols, beers, brewery slop, cider, distillery wort, extracts, flavors, juice, mash, soft drink syrups, wines.

**PHARMACEUTICAL:** Moving medicines, cosmetics, process chemicals, lotions, preparations, filtering solutions, used as a filling line supply pump.

**WARNING:** Do not pump solvents, thinners, or gasoline as explosion may result causing property damage, severe personal injury or death.

#### OPERATING INSTRUCTIONS

- 1. INSTALLATION** – Pump may be mounted in any position. The rotation of the pump shaft determines the location of the pump's intake and discharge ports. Refer to dimensional drawing. Pump is normally assembled at factory for clockwise rotation looking at end cover. If counterclockwise rotation is desired, follow steps 1 and 2 of disassembly and step 9 of assembly instructions to change direction of impeller blade deflection under cam.
- 2. DRIVE** – Belt or direct with flexible coupling.  
Belt Drive: Overtight belt load will reduce pump bearing life.  
Direct Drive: Clearance should be left between drive shaft and pump shaft when installing coupling. Always mount and align pump and drive shaft before tightening the coupling set screw. If pulley or coupling must be pressed on shaft, remove end cover and impeller to support shaft from impeller end during press operation. Do not hammer pulley or coupling on shaft; this may damage bearing or seal.  
Capacitor start motor is required to overcome starting torque of impeller.

**WARNING:** Exposed pulley and belts can cause injury, install shield around pulleys and belts.

#### VARIATIONS AVAILABLE

| MODEL      | DESCRIPTION  |
|------------|--|
| 30560-0005 | Standard Pressure, Neoprene Impeller, Carbon Seal, ACME Ports            |
| 30560-0015 | High Pressure, Neoprene Impeller, Carbon Seal, ACME Ports                |
| 30560-0105 | Standard Pressure, Neoprene Impeller, Tungsten Carbide Seal, ACME Ports  |
| 30560-0115 | High Pressure, Neoprene Impeller, Tungsten Carbide Seal, ACME Ports      |
| 30560-1005 | Standard Pressure, Neoprene Impeller, Carbon Seal, Clamp Ports           |
| 30560-1015 | High Pressure, Neoprene Impeller, Carbon Seal, Clamp Ports               |
| 30560-1105 | Standard Pressure, Neoprene Impeller, Tungsten Carbide Seal, Clamp Ports |
| 30560-1115 | High Pressure, Neoprene Impeller, Tungsten Carbide Seal, Clamp Ports     |

3. SPEEDS – 100 RPM to the maximum shown in the performance curves. For longer pump life, operate at lowest possible speeds. Lower speeds are required for viscous liquids. Consult the factory for proper speeds and horsepower requirements.
4. SELF-PRIMING – Primes at low or high speeds. For vertical dry suction lift of 10 feet, a minimum of 800 RPM is required. Pump will produce suction lift up to 22 feet when wet. BE SURE SUCTION LINES ARE AIRTIGHT OR PUMP WILL NOT SELF-PRIME.
5. DISCHARGE - When transferring liquids further than 25', use one size larger discharge line than discharge port size.
6. RUNNING DRY – Unit depends on liquid pumped for lubrication. DO NOT RUN DRY for more than 30 seconds. Lack of liquid will damage the impeller.
7. PUMPAGE COMPATIBILITY – Consult the Chemical Resistance Guide in the JABSCO Industrial Pump Catalog (available upon request from ITT Jabsco) or factory for proper body materials and impeller compounds. If corrosive fluids are handled, pump life will be prolonged if pump is flushed with a neutralizing solution after each use or after each work day. A Tungsten Carbide Seal variation is available for pumping liquids that contain abrasives or are highly corrosive.
8. PRESSURES – Consult Performance Curves for maximum recommended pressures for pump in continuous operation. If pressures exceed those shown, consult the factory.
9. TEMPERATURES – The operating temperature limits of the pump depends on the impeller compound. The following ranges apply: Neoprene - 45° to 150° F (7° to 65° C).
10. CLEANING – Before using pump it should be disassembled and cleaned to remove any dust and dirt resulting from storage or shipping. Wash parts in standard cleaning solutions approved for handling stainless steel. Thoroughly rinse before reassembly. DO NOT USE IODINE BASED SANITIZERS as the iodine attacks the elastomer materials used in the impeller.  
  
All parts have been expertly machined and polished. HANDLE WITH CARE. DO NOT DROP OR MISHANDLE.
11. IMPELLER TORQUE – The torque required to initiate rotation of a new impeller in a dry pump body is:  
Standard Pressure Impeller (8981-SERIES):  
Forward = 1.5 pounds force – feet  
Reverse = 4.3 pounds force – feet  
High Pressure Impeller (8840-SERIES):  
Forward = 3.0 pounds force – feet  
Reverse = 6.0 pounds force – feet  
These values may vary slightly due to impeller compounding, blade set, and body material of construction. Consult factory for more information.
12. SPARE PARTS – To avoid costly shutdowns, keep a spare JABSCO impeller, seal and O-ring set on hand.

## SERVICE INSTRUCTIONS

### DISASSEMBLY

1. Remove the four end cover screws. Remove end cover and O-ring.
2. Remove the four screws, holding the body to the bearing housing flange. Slide body, complete with impeller and wearplate, from pedestal and shaft assembly.
3. Remove mechanical seal by inserting two screwdrivers behind seal collar, and gently lever collar and seal assembly forward on shaft. Use extreme care not to mar shaft surface. Remove seal seat and rubber cup from recess in wearplate.
4. From the drive end of the bearing housing, pry out bearing seal by inserting a screwdriver blade between OD of the seal and housing. Remove retaining ring. Very carefully withdraw shaft and bearing assembly.
5. Remove inner bearing seal and retaining ring.
6. To remove bearings from shaft an arbor press is required. If an arbor press is not available then a bearing extractor may be used. Supporting inner race of bearing, apply a steady pressure on shaft until bearing slides free. Repeat this procedure to remove second bearing.

### ASSEMBLY

1. To replace bearing on shaft. Support ball bearing on its inner race and locate shaft onto bearing. Apply a steady pressure to the shaft until bearing locates against shoulder on shaft. Repeat for second bearing.
2. Fit retaining ring and bearing seal into impeller end of bearing housing. Spring on bearing seal to face outwards.
3. Apply bearing grease around and between bearings, filling cavity between bearings two thirds full. Smear grease on shaft where bearing seal locates. Push shaft and bearing assembly into bearing housing.
4. Replace retaining ring and outer bearing seal with spring facing outwards.
5. Replace mechanical seal by sliding spacer onto shaft up to locating shoulder, then smear shaft with light lubricating oil. Push on seal gently until it engages with spacer. Fit rubber cup and seal seat into wearplate.
6. Insert impeller in pump body, fit O-ring in each end of the pump body. Fit wearplate to body.
7. Slide wearplate and body assembly over shaft, position wearplate in housing. Fit body to pedestal with screws. Torque screws to 60 in. lbs.

Note: A gap should be maintained between bearing housing and body. DO NOT overtighten screws.

8. Fit end cover and end cover screws. Torque screws to 60 in. lbs.
9. Changing Pump Rotation (looking at end cover):  
Clockwise Rotation: Insert impeller into pump body with blades bending counterclockwise  
Counterclockwise Rotation: Insert impeller into pump body with blades bending clockwise.

## PARTS LIST

| KEY | DESCRIPTION  | QTY. REQ. | PART NO.                 |
|-----|--|-----------|--------------------------|
| 1   | Bearing Housing  | 1         | 18753-0184               |
| 2   | Body:<br>2-A. Clamp Ports<br>2-B. ACME Ports   | 1         | 18753-0359<br>18753-0360 |
| 3   | End Cover  | 1         | 18753-0361               |
| 4   | Wearplate  | 1         | 18753-0200               |
| 5   | Shaft  | 1         | 18753-0205               |
| 6   | Impeller:<br>Standard Pressure – Neoprene<br>High Pressure – Neoprene  | 1         | 8981-0005<br>8840-0005   |
| 7   | Spacer   | 1         | 18753-0225               |
| 8   | Seal Seat: Nitrile   | 1         | 18753-0362               |
| 9   | Seal Mech.:<br>Carbon – Nitrile<br>Tungsten Carbide – Nitrile  | 1         | 18753-0363<br>18753-0364 |
| 10  | Bearing Seal   | 2         | 18753-0258               |
| 11  | O-Ring: Nitrile  | 2         | 18753-0263               |
| 12  | Retaining Ring   | 2         | 18753-0270               |
| 13  | Bearing  | 2         | 18753-0274               |
| 14  | Screw Kit:<br>Consists of<br>Screw, Hex Hd. M6 x 20mm (4)<br>Screw, Pan Hd. M6 x 20mm (4)<br>Washer, Flat M5 (4) | 1         | 18753-0281               |

### EXPLODED VIEW

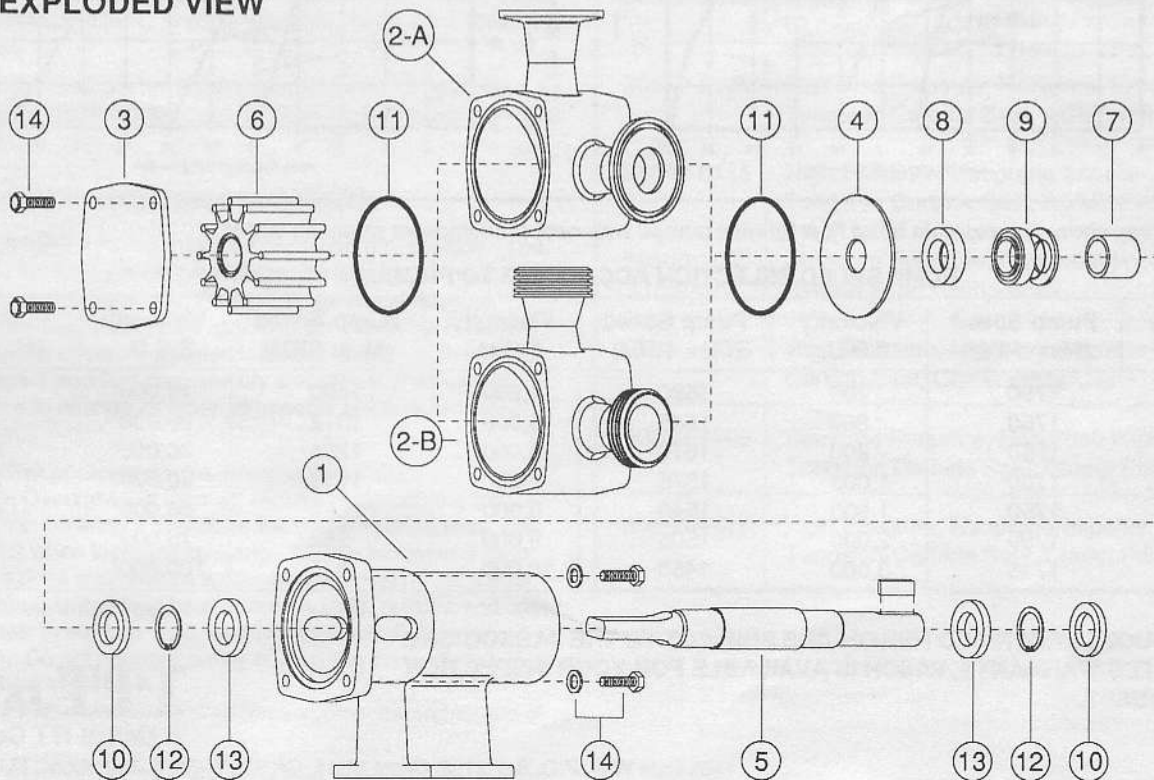

## DIMENSIONAL DRAWINGS

INCHES (Millimetres)

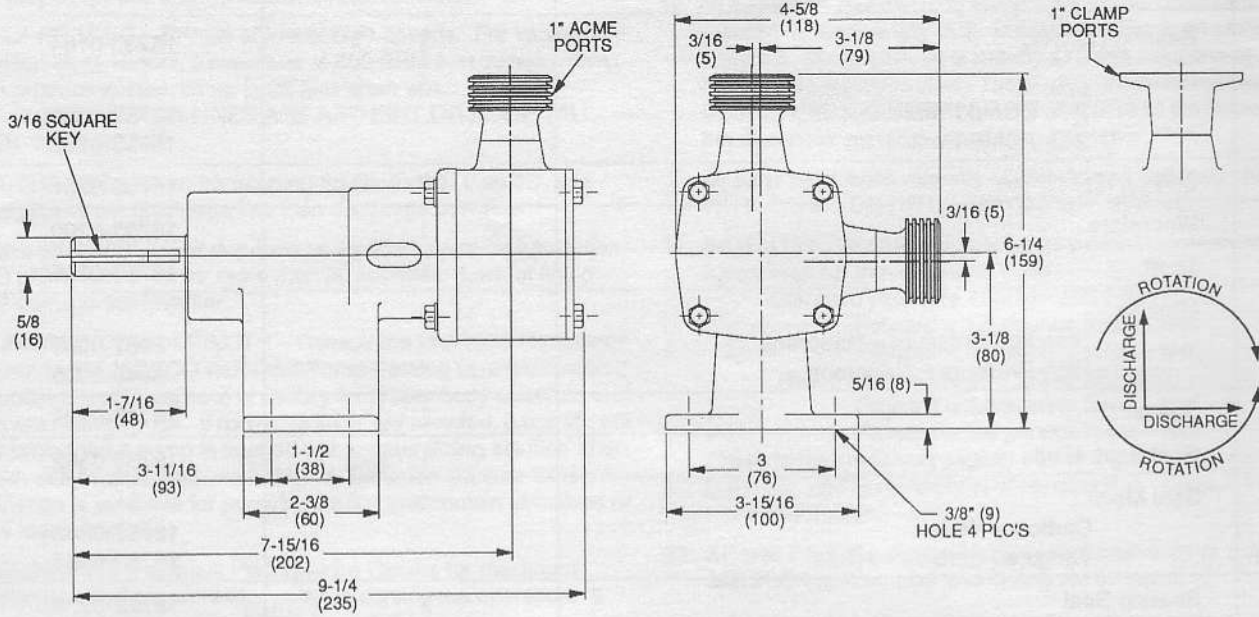

## PERFORMANCE CURVES

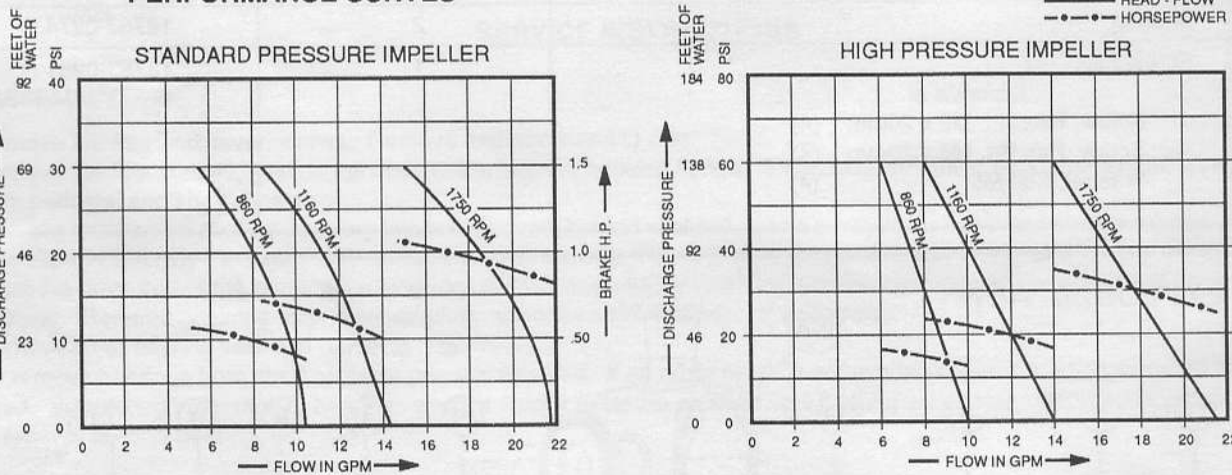

NOTE: Curves show approximate head flow for new pumps with neoprene impeller pumping water.

### PUMP SPEED SELECTION ACCORDING TO PRODUCT VISCOSITY

| Viscosity<br>S.S.U. | Pump Speed<br>(Max. RPM) | Viscosity<br>S.S.U. | Pump Speed<br>(Max. RPM) | Viscosity<br>S.S.U. | Pump Speed<br>(Max. RPM) | Viscosity<br>S.S.U. | Pump Speed<br>(Max. RPM) |
|---------------------|--------------------------|---------------------|--------------------------|---------------------|--------------------------|---------------------|--------------------------|
| 50                  | 1750                     | 700                 | 1680                     | 4,000               | 1400                     | 15,000*             | 787                      |
| 100                 | 1750                     | 800                 | 1645                     | 5,000               | 1312                     | 20,000*             | 700                      |
| 200                 | 1750                     | 900                 | 1610                     | 6,000               | 1225                     | 30,000*             | 612                      |
| 300                 | 1750                     | 1,000               | 1575                     | 7,000               | 1138                     | 40,000*             | 525                      |
| 400                 | 1750                     | 1,500               | 1540                     | 8,000               | 1050                     | 50,000*             | 437                      |
| 500                 | 1750                     | 2,000               | 1505                     | 9,000               | 962                      | 75,000*             | 298                      |
| 600                 | 1715                     | 3,000               | 1450                     | 10,000              | 875                      | 100,000*            | 175                      |

\* Use High Pressure Impeller

**THE PRODUCTS DESCRIBED HEREIN ARE SUBJECT TO THE JABSCO ONE YEAR LIMITED WARRANTY, WHICH IS AVAILABLE FOR YOUR INSPECTION UPON REQUEST.**

**ITT JABSCO**  
A Unit of ITT Corporation

1485 Dale Way, P.O. Box 2158, Costa Mesa, CA 92628-2158, Telephone: (714) 545-8251  
Bingley Road, Hoddesdon, Hertfordshire EN11 0BU England, Telephone: +44-992-467191