

JABSCO®

Models 30520-4XXX 30520-2XXX

Models 30520-4XXX, 30520-2XXX

SELF-PRIMING PUMPS

FEATURES

- Pump Type:** 30520-4XXX Close Coupled
30520-2XXX Pump Head
- Body:** 316 Stainless Steel
- Impeller:** Neoprene, Nitrile or Viton*
- Shaft Seal:** Mechanical, Carbon-on-Ceramic;
or Tungsten Carbide; Nitrile and Viton
- Ports:** 1" NPT Internal
- Shaft:** 316 Stainless Steel
- Motor:** 230 Vac, Single Phase, 60Hz, 2 HP,
1750 RPM, TEFC, C-Face, 145TC Frame,
Overload Protected, Capacitor Start.
- Weight:** 30520-4XXX 56.0 lbs (25,4 kg) Approx.
30520-2XXX 12.0 lbs (5,5 kg) Approx.

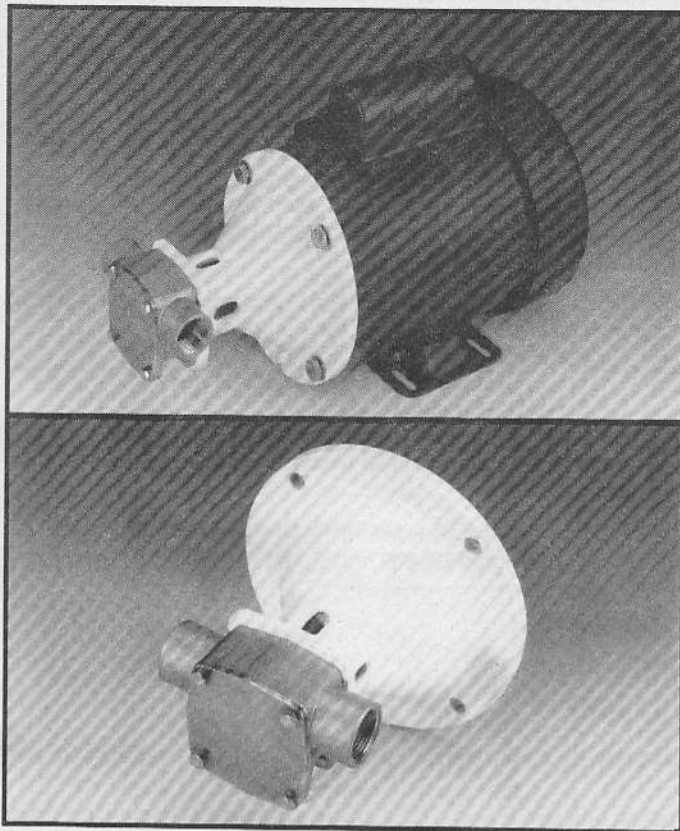

MOTOR WARNING



MOTOR CAN SPARK.
EXPLOSION & DEATH
CAN OCCUR.

DO NOT USE WHERE
FLAMMABLE VAPORS
ARE PRESENT.

APPLICATIONS

INDUSTRIAL: Circulating and transferring, velocity-mixing, pumping machine tool coolants, spill return, sump drainage, chemicals, pharmaceuticals, soap, liquors, ink, dyes, alcohol, dilute acids, tanning liquors, glycerine, brine, etc.

PHARMACEUTICAL: Processing medicines, lotions and preparations. Filtering pharmaceutical solutions. Filling line supply pump.

PAPER PROCESSING: Transferring and applying starches, sizes, etc. Circulating and processing wood pulp slurries.

FOOD, BEVERAGE & DAIRY: Transfer brines, vinegar, syrups during processing, liquids containing solids in suspension such as chopped tomatoes, nuts, etc. Removal of distillery wort and brewery slop. Processing viscous materials such as peanut butter, mayonnaise, ketchup, honey, etc. (low speed). Pumping whisky, wine, rums, juices and ciders.

AGRICULTURAL: Transferring liquid fertilizers, herbicides and pesticides.

WARNING: Do not pump flammable solvents, thinners or gasoline as explosion may result causing property damage, severe personal injury or death.

VARIATIONS AVAILABLE

MODEL	DESCRIPTION
30520-4001 30520-2001	Standard Pressure, Neoprene Impeller, Carbon Seal
30520-4003 30520-2003	Standard Pressure, Nitrile Impeller, Carbon Seal
30520-4004 30520-2004	Standard Pressure, Viton Impeller, Carbon Seal
30520-4101 30520-2101	Standard Pressure, Neoprene Impeller, Tungsten Carbide Seal
30520-4103 30520-2103	Standard Pressure, Nitrile Impeller, Tungsten Carbide Seal
30520-4104 30520-2104	Standard Pressure, Viton Impeller, Tungsten Carbide Seal

Viton* is a trademark of E.I. Du Pont de Nemours and Company.

OPERATING INSTRUCTIONS

1. **INSTALLATION** – Pump may be installed in any position. The rotation of the pump shaft determines the location of the pump's intake and discharge ports. (Refer to dimensional drawing.) Pump is normally assembled at factory for clockwise rotation (looking at end cover). If counter clockwise rotation is desired, follow steps 1 and 2 of disassembly and step 7 of assembly instructions to change direction of impeller blade deflection under cam.
2. **MOTOR SELECTION** – Pump head is designed to fit a 145TC Frame NEMA C-face motor. Motor should be rated 2 horsepower at 1750 RPM with a service factor of one. Due to high bearing loads, motor should be ball bearing equipped with the front bearing locked against axial movement. Motor should be capacitor start and foot mounted.
3. **SPEEDS** – 100 RPM to the maximum shown in the performance curves. Consult the factory for operation at speeds above these shown. For longer pump life, operate at lowest possible speeds. Lower speeds are required for viscous liquids. Consult the factory for proper speeds and horsepower requirements.
4. **SELF-PRIMING** – Pump will produce suction lift up to 22 feet when wet. **BE SURE SUCTION LINES ARE AIRTIGHT OR PUMP WILL NOT SELF-PRIME.**
5. **DISCHARGE** – When transferring liquids further than 25', use one size larger discharge line than discharge port size.
6. **RUNNING DRY** – Unit depends on liquid pumped for lubrication. **DO NOT RUN DRY** for more than 30 seconds. Lack of liquid will damage the impeller and seal.
7. **CHEMICAL COMPATIBILITY** – Consult the Chemical Resistance Guide in the JABSCO Industrial Pump Catalog (available upon request from the ITT Jabsco) or factory for proper body materials and impeller compounds. If corrosive fluids are handled, pump life will be prolonged if pump is flushed with a neutralizing solution after each use or after each work day. Tungsten Carbide Seal variation is available for pumping liquids that contain abrasives or are highly corrosive.
8. **PRESSURES** – Consult Performance Curves for maximum recommended pressures for pumps in continuous operation. If pressures exceed those shown, consult the factory.
9. **TEMPERATURE** – The operating temperature limits of the pump depends on the impeller compound. The following ranges apply: Neoprene impeller - 45° to 180° F (7° to 82° C), Nitrile impeller - 50° to 180° F (10° to 82° C), Viton impeller - 60° to 180° F (15° to 82° C).
10. **IMPELLER TORQUE** – The torque required to initiate rotation of a new impeller in a dry pump body is:
Standard Pressure Impeller (14282-Series):
Forward = 4.8 pounds force - feet
Reverse = 11.2 pounds force - feet
These values may vary slightly due to impeller compounding, blade set, and body material of construction. Consult factory for more information.
11. **SPARE PARTS** – To avoid costly shutdowns, keep a spare Jabsco impeller, seal and O-ring set on hand.

SERVICE INSTRUCTIONS

DISASSEMBLY

1. Remove the four end cover screws. Remove end cover and O-ring.
2. Remove the four screws holding the body to the adapter flange. Slide body, complete with impeller and wearplate, from adapter and shaft.
3. Remove mechanical seal by inserting two screwdrivers behind seal collar, and gently lever collar and seal assembly forward on shaft. Use extreme care not to mar shaft surface. Remove seal seat and rubber cup from recess in wearplate.
4. Remove the four screws holding the adapter to the motor and remove the adapter.
5. The stub shaft is held in place with set screws and Loctite* RC/680 retaining ring compound. Extreme care must be taken not to damage the motor shaft and bearings when removing the stub shaft. Heat shaft joint area to facilitate disassembly of set screws and stub shaft from motor shaft. **DO NOT EXCEED 300°F** when heating joint area. Once joint area has been heated, remove set screws and slide stub shaft from motor shaft.

ASSEMBLY

1. Liberally apply Loctite RC/680 retaining compound to the motor shaft and slide the stub shaft on, positioning the base of the stub shaft 0.37" from the bolt mounting surface of the motor and two of the four set screw holes over the keyway in the motor shaft. For clarification refer to Figure 1 below. Loctite aids in preventing fretting and subsequent shaft failure. Apply Loctite to the two dog point (flat point) set screws, position in the set screw holes aligned with the keyway of the motor shaft and torque to 55 - 60 in. lbs. Apply Loctite to the two cup point set screws and torque to 85 - 90 in. lbs. Wipe off excess Loctite.
2. Replace the adapter on the motor and torque the four mounting screws to 20 ft. lbs.
3. Replace mechanical seal by sliding spacer onto shaft up to locating shoulder, then smear shaft with light lubricating oil. Push on seal gently until it engages with spacer. Fit rubber cup and seal seat into wearplate.
4. Insert impeller in pump body, fit O-ring in each end of the pump body.
5. Slide wearplate and body assembly over shaft, position wearplate in housing. Fit body to pedestal with screws. Torque screws to 60 in. lbs.
Note: A gap should be maintained between bearing housing and body. **DO NOT** overtighten screws.
6. Fit end cover and end cover screws. Torque screws to 60 in. lbs.
7. Changing Pump Rotation (looking at end cover):
 - a. Clockwise Rotation: Insert impeller into pump body with blades bending counterclockwise.
 - b. Counterclockwise Rotation: Insert impeller into pump body with blades bending clockwise.

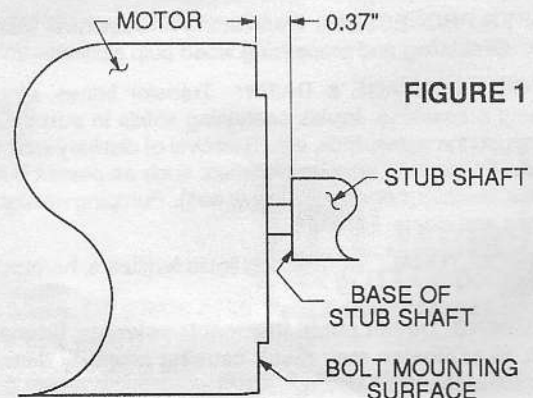

PARTS LIST

KEY	DESCRIPTION	QTY. REQ.	MODEL 30520-4XXX PART NO.	QTY. REQ.	MODEL 3052-2XXX PART NO.
1	Adapter	1	18753-0216	1	18753-0216
2	Body	1	18753-0189	1	18753-0189
3	End Cover	1	18753-0195	1	18753-0195
4	Wearplate	1	18753-0200	1	18753-0200
5	Shaft	1	18753-0211	1	18753-0211
6	Impeller: Standard Pressure - Neoprene Standard Pressure - Nitrile Standard Pressure - Viton	1	14282-0001 14282-0003 14282-0004	1	14282-0001 14282-0003 14282-0004
7	Motor, 2 HP, 230 Vac, 1Ph, 60Hz, TEFC, C-Face, 145 TC Frame	1	18753-0339		
8	Spacer: Carbon or Tungsten Carbide	1	18753-0227	1	18753-0227
9	Seal Seat: Nitrile Viton	1	18753-0235 18753-0236	1	18753-0235 18753-0236
10	Seal Mech.: Carbon - Nitrile Carbon - Viton Tungsten Carbide - Nitrile Tungsten Carbide - Viton	1	18753-0245 18753-0246 18753-0247 18753-0248	1	18753-0245 18753-0246 18753-0247 18753-0248
11	O-Ring: Nitrile Viton	2	18753-0263 18753-0264	2	18753-0263 18753-0264
12	Screw Kit: consists of Screws, Hex Hd. 3/8-16 x 1" (4) Screws, Hex Hd. M6 x 16mm (4) Screws, Hex Hd. M6 x 10mm (4) Set Screw, Cup Pt. 1/4-20 x 3/8 (2) Set Screw, Dog Pt. 1/4-20 x 3/8 (2) Washers, Flat 3/8 (4) Washers, Flat M6 (4)	1	18753-0282	1	18753-0282

EXPLODED VIEW

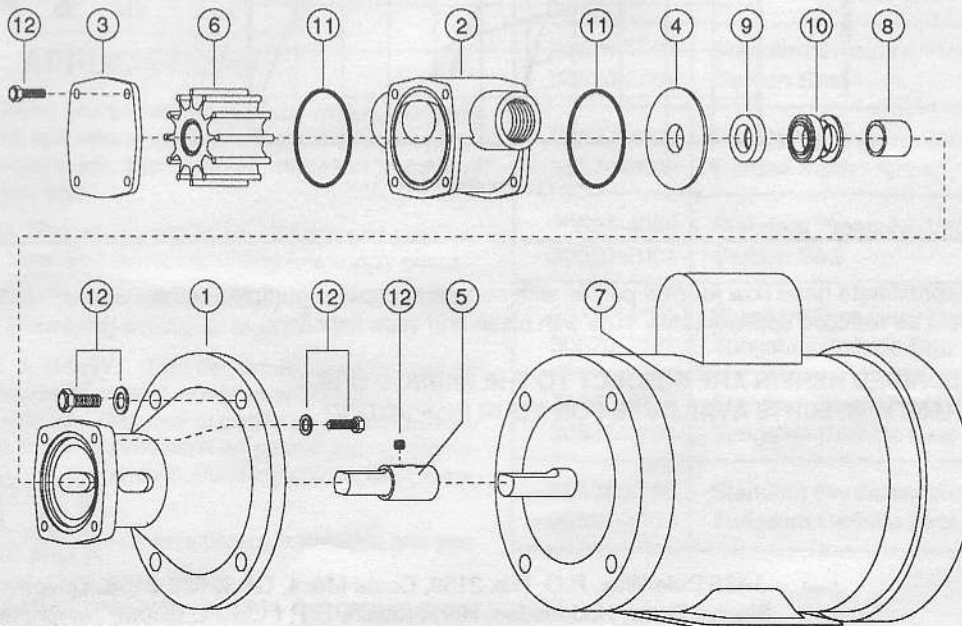

DIMENSIONAL DRAWINGS INCHES (Millimetres)

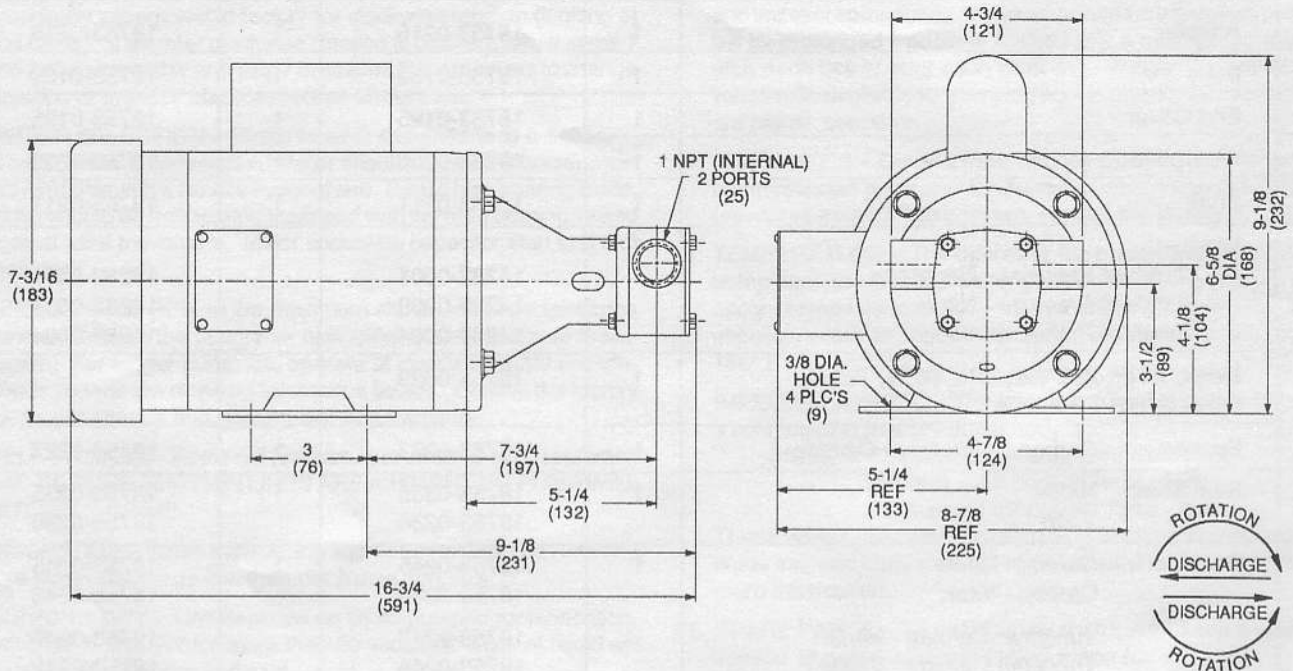

PERFORMANCE CURVES

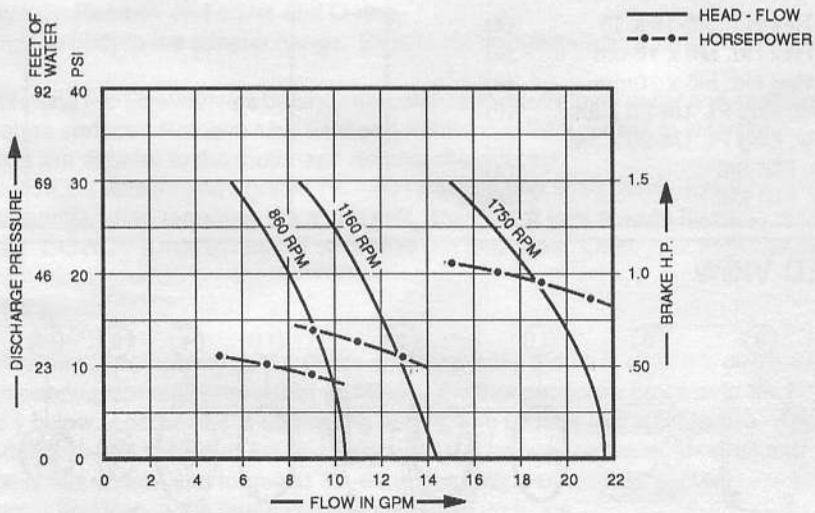

NOTE: Curve shows approximate head flow for new pumps with neoprene impeller pumping water. Capacities should be reduced approximately 10% with nitrile and viton impellers.

THIS PRODUCTS DESCRIBED HEREIN ARE SUBJECT TO THE JABSCO ONE YEAR LIMITED WARRANTY, WHICH IS AVAILABLE FOR YOUR INSPECTION UPON REQUEST.

ITT JABSCO
A Unit of ITT Corporation

1485 Dale Way, P.O. Box 2158, Costa Mesa, CA 92628-2158, Telephone: (714) 545-8251
Bingley Road, Hoddesdon, Hertfordshire EN11 0BU England, Telephone: +44-992-467191