



# Model 30450-Series

## 'CENTRI-MAX'

### 10 GPM Automatic Multi-Outlet Water System Pump

Ideal for 5 or more Outlets or as a Washdown Pump

#### FEATURES

- Super Quiet
- Ultra Smooth Flow
- Compact and Easy To Install
- High Capacity
- Check Valve (included)
- Easy Flow Strainer (included)
- Automatic Dry Tank Shut-Off
- Unique Flow Sensor Shut-Off
- Meets USCG Electrical Requirements including Ignition Protection

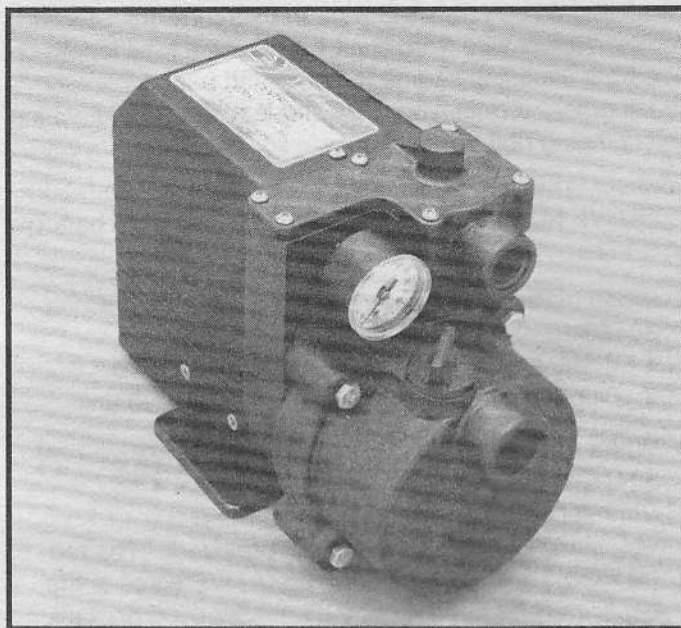

Model 30450-Series

Optional 'Run Dry' warning alarm and on-off control is available. Order MODEL 30440-1000.



#### APPLICATIONS/PERFORMANCE

PAR Model 30450-Series Water Pressure System provides "at home" convenience for the larger pleasure boat, motor coach/bus conversion and commercial vessels. Maximum flow from a very compact size. Provides up to 10 gallons of fresh water per minute to service multiple outlets.

#### SPECIFICATIONS

- Flow - 10 GPM/38 LPM
- Pump Body - Noryl®
- Pump Design - Self Priming Centrifugal
- Suction Lift - 4 feet (1.2 m)
- Ports - 3/4" NPT/BSP inlet  
1/2" NPT/BSP outlet  
(Note: Adaptor for 3/4" outlet supplied)
- Motor - Permanent Magnet with Thermal Overload and Ignition Protection
- Shipping weight - 7.5 lb (3.5 kg) - approx.

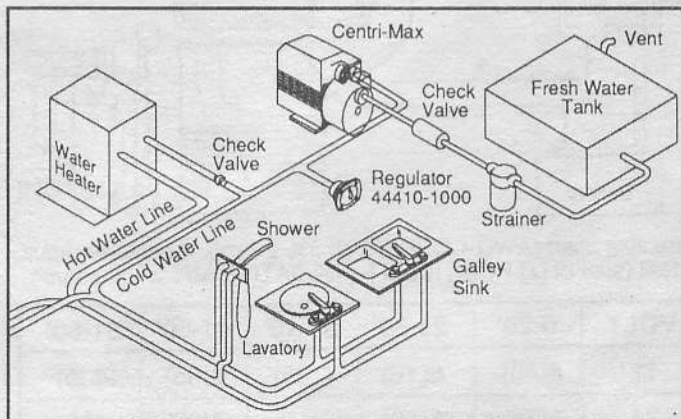

#### ELECTRICAL DATA

MODEL	GPM/ LPM	VOLTS	Nominal psi (bar)		AMP DRAW @ 10 psi (.7 bar)	FUSE/ BREAKER*
			CUT-IN	CUT-OUT		
30450-0012	10/38	12 Vdc	15 (1.0)	40 (2.8)	30	40
30450-0024	10/38	24 Vdc	15 (1.0)	40 (2.8)	17	25
30450-0212	10/38	12 Vdc	10 (0.7)	30 (2.1)	24	30
30450-0224	10/38	24 Vdc	10 (0.7)	30 (2.1)	14	20

\* Customer supplied, not included with pump.

Noryl is a registered trademark of General Electric Company.

# INSTALLATION

## WIRING

CENTRI-MAX pumps have a relatively high amperage draw and must be powered from an independent circuit of adequate capacity to keep voltage drop to a minimum. Particular attention must be paid to proper size wiring to ensure optimum operation of the pump. The electrical circuit should be protected with an overcurrent protection device. Select wire from chart below. Use total length of wire from electrical source to pump and back. Install rubber terminal boot on wire leads before attaching and crimping ring terminals.

Connect (+) POSITIVE lead from power source to (+) POSITIVE terminal and (-) NEGATIVE lead from battery ground to (-) NEGATIVE terminal.

- When using optional alarm/on-off switch model 30440-1000:
  1. Remove wiring pigtail from unit. **DISCARD.**
  2. Plug optional cable from alarm/switch into unit.

- When **not** using optional alarm/switch model 30440-1000:
 

Connect green and white wires of the pigtail to vessel/vehicle on/off switch (not provided). The red (+) POSITIVE and black (-) NEGATIVE wires of the pigtail may be used with customer supplied dry tank alarm but current draw must not exceed 2 amperes.

When an alarm is not used, the red and black wires of the pigtail should be cut off and the ends covered to protect from shorting out.

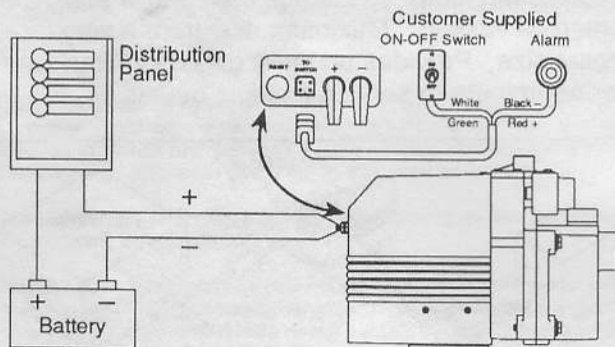

Wire size chart (AWG-COPPER) @ 3% V Drop. Length of circuit in feet (sum of [+] POSITIVE & [-] NEGATIVE wire lengths mm<sup>2</sup>).

VOLT	0-20'	21-30'	31-40'	41-50'	51-60'
12	8(10)	6(16)	4(25)	2(35)	2(35)
24	10(6)	8(10)	6(16)	4(25)	4(25)

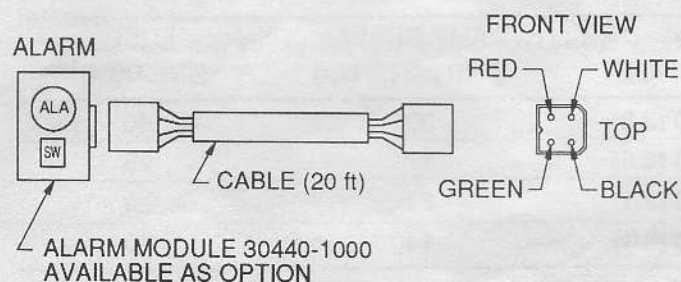

## PLUMBING

Basic Pump Connections

Inlet: 3/4" NPT/BSP

Outlet: 1/2" NPT/BSP

Note: Full flow performance is dependent on proper plumbing.

### ACCUMULATOR

AN ACCUMULATOR TANK IS NOT REQUIRED NOR EVEN DESIRED WITH THE CENTRI-MAX PUMP.



The **CENTRI-MAX** is a self-priming centrifugal pump that must be initially manually primed. The pump may be mounted above the level of the water supply, however, **below the water supply level is the preferred location.**

1. Mount the pump securely on a solid, level surface.
2. Use pipe sealant on all pipe threads before installing check valve, strainer, or plumbing. **DO NOT USE TEFLON\* (PTFE) TYPE TAPE ON THREADS.** Pieces of tape may enter pump and clog small water passages.
3. For installations where the pump is mounted at the same level or below the full tank water level (**THIS IS THE PREFERRED METHOD**), reinforced hose or flexible tubing may be used. Avoid kinks or fittings that could cause restrictions.
  - Install plumbing from water supply to Pumpgard strainer (36300-1000, provided, 3/4" NPT/BSP male threads).
  - Install plumbing from strainer to check valve (30473-1000, provided), install check valve (3/4" NPT/BSP female threads) in the line as close to the pump inlet as possible using rigid fittings or pipe.
4. For installations where the pump is mounted above the high level of the water supply (a maximum of 4 ft [1.2 m] to the center line of the pump is allowed), rigid inlet piping is **REQUIRED**. Do **NOT** use flexible piping or hose.
  - Install the check valve (30473-1000, provided, 3/4" NPT/BSP female threads) as close to the water supply tank as possible.
  - Install rigid 3/4" piping, keeping length and fittings to a minimum, (a maximum vertical height above the full tank water level of 4 ft [1.2 m] is allowed).
  - Install the Pumpgard strainer (36300-1000, provided, 3/4" NPT/BSP male threads) in the line before the pump. The strainer may be installed at any convenient location in the inlet line.
5. Outlet port is 1/2" NPT/BSP female thread. Any type plumbing may be used on the discharge side of the pump. Generally, optimum performance will be achieved with no less than 1/2 inch ID line size. For installations with long runs or multiple bends, 5/8 to 3/4 inch ID tube or 3/4 inch pipe size should be used.

\* TEFLON is a registered trademark of E.I. DuPont de Nemours and Company.



## WIRING DIAGRAM

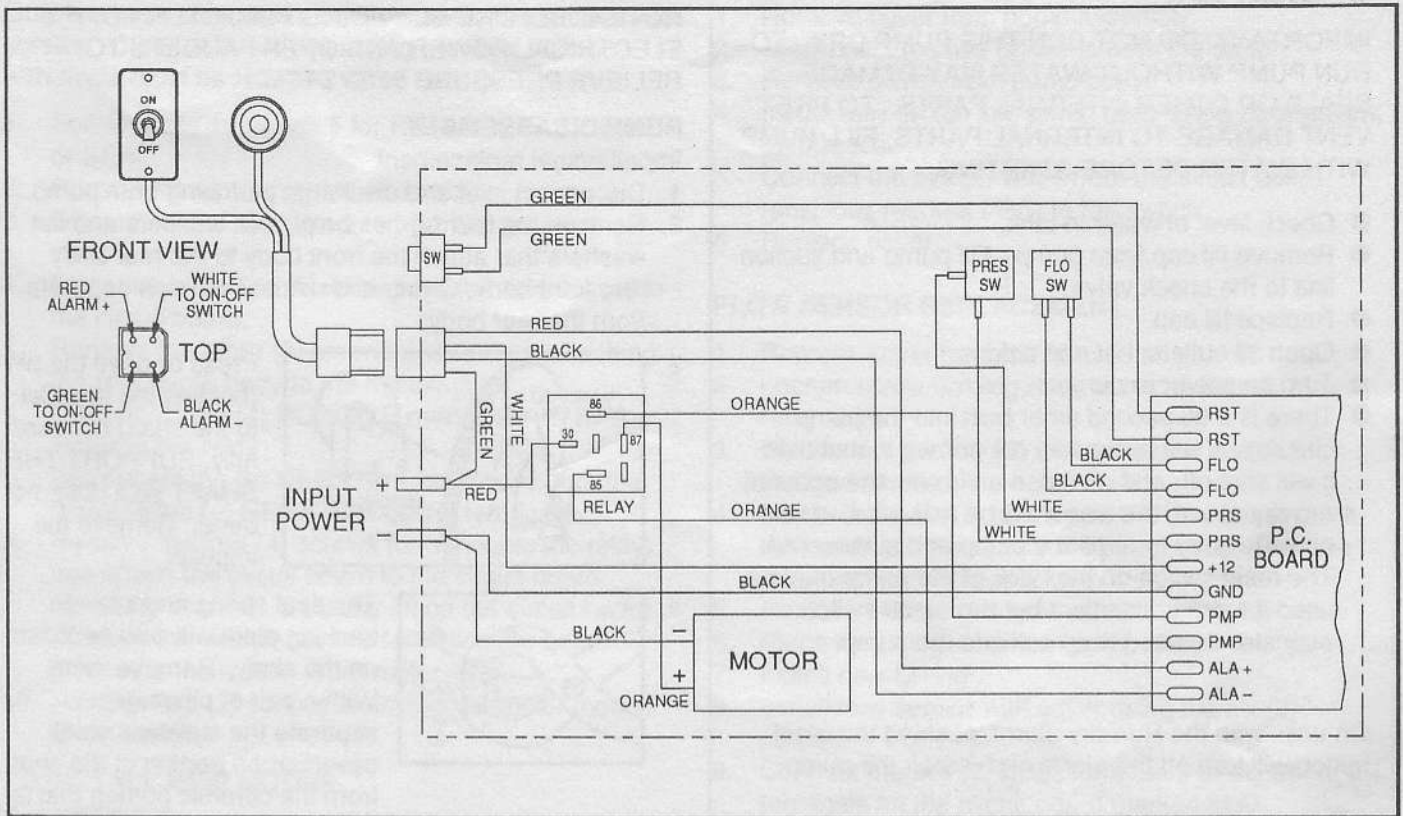

## PLUMBING DIAGRAM

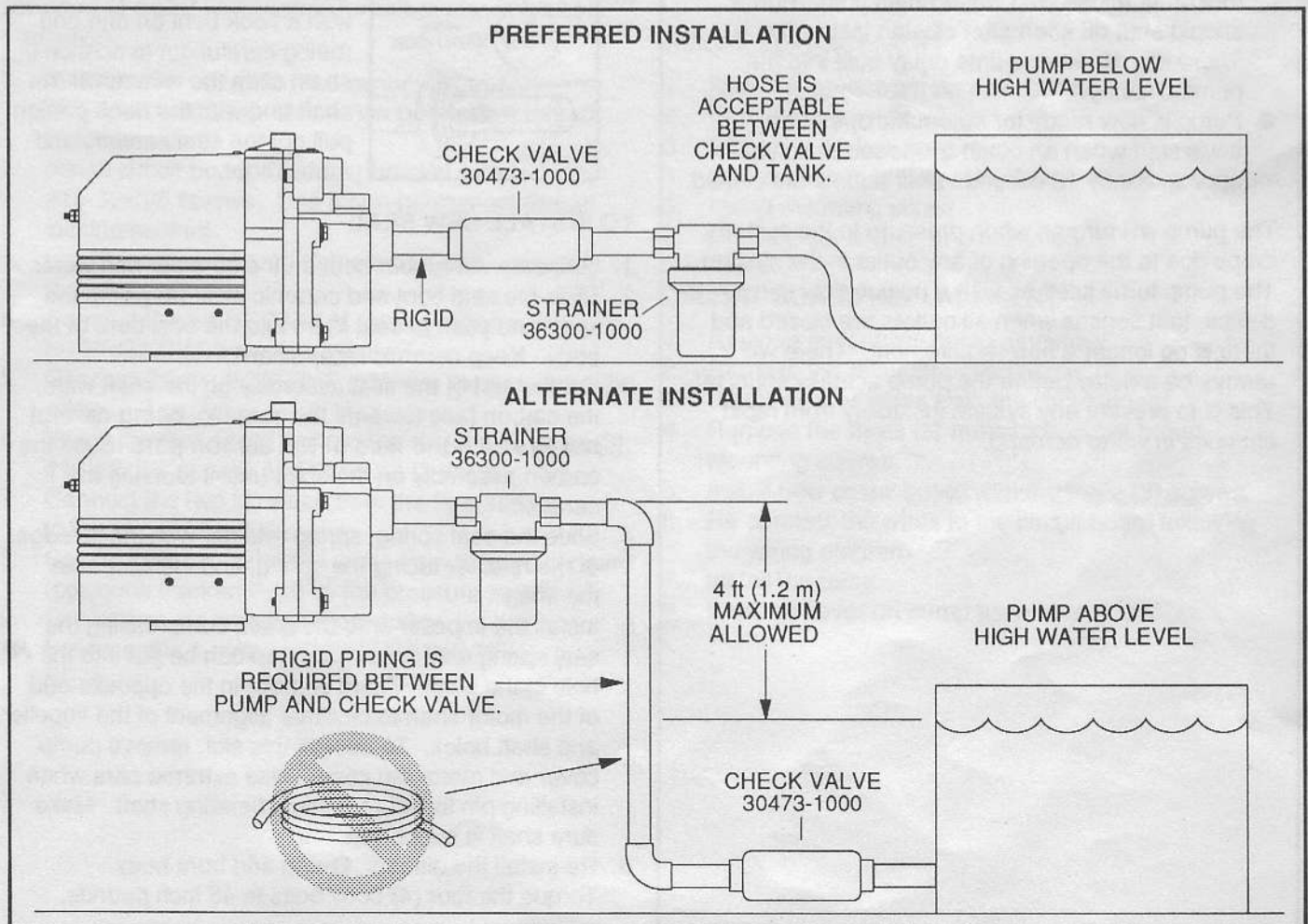

## OPERATION

**IMPORTANT: DO NOT RUN THIS PUMP DRY. TO RUN PUMP WITHOUT WATER MAY DAMAGE SEALS OR OTHER INTERNAL PARTS. TO PREVENT DAMAGE TO INTERNAL PARTS, FILL PUMP WITH WATER BEFORE STARTING.**

- Check level of water in tank.
- Remove fill cap from pump. Fill pump and suction line to the check valve.
- Replace fill cap.
- Open all outlets, hot and cold.
- Turn on power to pump.
- There is a 90 second timer built into the pump circuitry. If the pump has not primed in that time it will shut off, and on those units with the optional run-dry alarm, the alarm will be activated. It will be necessary to re-fill the pump and suction line. The reset switch on the back of the pump may be used if more convenient but the on-off switch may also be used to re-activate the pump.

On units with the Run-dry alarm, pushing the reset button will turn off the alarm and restart the pump.

- Close each outlet as flow becomes steady and free of air (close cold water outlet first). Pump should shut off soon after closing last outlet. There is a 10 second time delay built into the pump circuitry.
- Pump is now ready for automatic operation. It will start when an outlet is opened and stop approximately 10 seconds after outlets are closed.

The pump will turn on when pressure in the system drops due to the opening of any outlet in the system. The pump turns itself off with a unique flow sensor device, that senses when all outlets are closed and there is no longer a flow requirement. There will always be a delay before the pump actually shuts off. This is to prevent any system instability from rapid changes in water demand.

## SERVICE INSTRUCTIONS

**NOTICE: BEFORE SERVICING PUMP, TURN OFF ELECTRICAL POWER AND OPEN FAUCETS TO RELIEVE PRESSURE IN SYSTEM.**

### PUMP DISASSEMBLY

#### Impeller/seal replacement

1. Disconnect inlet and discharge plumbing from pump.
2. Remove the four (4) hex bolts, lock washers and flat washers that attach the front body to the rear body. The front body, O-ring and diffuser will now separate from the rear body.

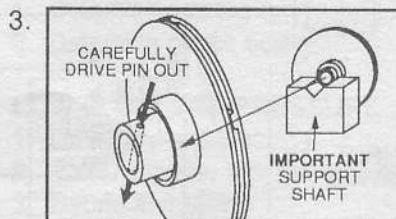

Press or drive the pin (holding the impeller to the shaft) out carefully, SUPPORT THE SHAFT so it does not bend. Remove the impeller.

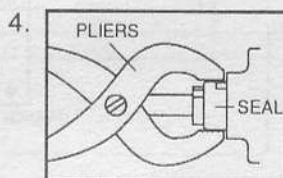

The seal spring and spring backing plate will now be loose on the shaft. Remove them. With a pair of pliers gently separate the stainless steel case/carbon portion of the seal from the ceramic portion that is seated in the pump body.

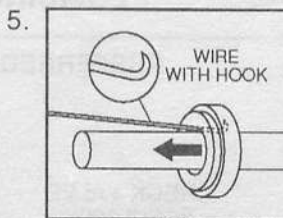

Using a small piece of stiff wire with a hook bent on one end (being careful not to scratch the shaft) slide the wire down the shaft and with the hook portion pull out the seal ceramic and rubber boot.

### TO INSTALL NEW SEAL

1. Lubricate the rubber boot on the ceramic with water.
2. Slide the seal boot and ceramic assembly onto the shaft and push to seat them into the seal bore of the body. Keep ceramic face "clean".
3. Put the rest of the seal assembly on the shaft with the carbon face towards the ceramic, **being careful not to touch the face of the carbon part**. Slide the carbon assembly on the shaft until it touches the ceramic.
4. Slide the seal spring, spring retainer with the lip edge of the retainer facing the spring, and impeller onto the shaft.
5. Install the impeller onto the shaft, compressing the seal spring until the impeller pin can be put into the hole in the shaft. There is a slot in the opposite end of the motor shaft to facilitate alignment of the impeller and shaft holes. To access this slot, remove pump cover and motor fan cover. Use extreme care when installing pin to insure against bending shaft. Make sure shaft is supported.
6. Re-install the diffuser, O-ring and front body. Torque the four (4) body bolts to 45 inch pounds.



## MOTOR REPLACEMENT

Only for those units with mounting brackets attached with screws. Other units with mounting brackets attached with rivets must be returned to the factory.

1. Follow steps 1 through 5 for REPLACING IMPELLER or SEAL.
2. Remove cover from pump assembly.
3. Disconnect the two (2) wires from the pressure switch.
4. Disconnect the two (2) wires from the flow sensor to the circuit board.
5. Remove the three (3) screws and O-rings attaching the rear pump body to the motor.
6. Disconnect the (+) POSITIVE orange wire from the motor to the relay.
7. Disconnect the (-) NEGATIVE black wire from the motor to the (-) NEGATIVE power terminal.
8. Remove the four (4) screws (one mounts the relay) that attach the circuit board to the circuit board mounting bracket. Carefully lift off the circuit board.
9. Remove the two (2) screws fastening the board bracket to the motor. Turn motor over.
10. Remove two (2) screws attaching the motor mount to the motor.

## TO INSTALL NEW MOTOR

**⚠ CAUTION** *IGNITION PROTECTION! Motor mount and circuit board mounting bracket **MUST** be securely fastened to motor with proper screws to insure ignition protection.*

1. Install motor mount to new motor with two (2) #10-32x3/8 screws. Use a non-permanent thread locking sealant.
2. Install circuit board mounting bracket with two (2) #10-32x3/8 screws. Use a non-permanent thread locking sealant.
3. Install the circuit board to the circuit board bracket including the relay.
4. Connect the (-) NEGATIVE (black) motor wire to the (-) NEGATIVE power terminal.
5. Connect the (+) POSITIVE (orange) motor wire to the relay.
6. Install the rear pump body to the motor with three (3) #10-32x5/8 screws and three (3) O-rings.
7. Connect the two (2) wires from the flow sensor to the circuit board.
8. Connect the two (2) white wires from the circuit board (positions marked PRS) to the pressure switch.
9. Replace cover onto pump assembly.
10. Follow steps 1 through 6 INSTALLING NEW SEAL.

## PRESSURE SWITCH REPLACEMENT

1. Remove cover from pump assembly.
2. Disconnect the two (2) wires from the switch.
3. Remove switch from pump body.
4. Install new switch into pump body using pipe sealant on threads.
5. Connect the two (2) wires from the circuit board (positions marked PRS) to the switch.
6. Replace cover.

## FLOW SENSOR REPLACEMENT

1. Remove cover from pump assembly.
2. Loosen screw holding relay to circuit board. Move relay aside.
3. Disconnect the two (2) wires from the switch to the circuit board.
4. Remove the six (6) screws on the flow sensor. Lift the cover and sensor off the pump body. Remove magnet disc from pump body.
5. Remove O-ring from groove.
6. Place new magnet disc in pump body.
7. Install new O-ring.
8. Install new sensor with cover using the six (6) screws.
9. Connect the two (2) wires from the flow sensor to the terminals on the circuit board marked FLO.
10. Re-position the relay and tighten the mounting screw.
11. Replace cover on pump assembly.

## RELAY REPLACEMENT

1. Remove cover from pump assembly.
2. Remove mounting screw.
3. Disconnect wires from relay.
4. Connect wires to new relay following wiring diagram.
5. Install mounting screw.
6. Replace cover on pump assembly.

## CIRCUIT BOARD REPLACEMENT

1. Remove cover from pump assembly.
2. Remove the relay mounting screw.
3. Disconnect all wires from the circuit board.
4. Remove the three (3) remaining circuit board mounting screws.
5. Install new circuit board with the three (3) screws.
6. Re-connect the wires to the circuit board following the wiring diagram.
7. Install the relay.
8. Replace cover on pump assembly.

## **TROUBLESHOOTING**

### **PULSATING FLOW - PUMP CYCLES ON AND OFF**

1. Too much air in system
2. Leak in system
3. Inlet piping too flexible
4. Inlet check valve leaks
5. Flow switch is defective.

### **FAILURE TO PRIME - MOTOR OPERATES, BUT NO FLOW AT OUTLET**

1. System is airlocked. Make sure that outlets are open and pump has been completely filled with water.
2. Leak in suction line
3. Pump impeller is defective or has come loose.

### **MOTOR FAILS TO TURN ON**

1. Incorrect polarity on power leads
2. Defective relay
3. Defective circuit board
4. Defective motor

### **PUMP FAILS TO TURN OFF AFTER ALL OUTLETS ARE CLOSED**

1. Defective flow switch
2. Defective circuit board

### **LOW FLOW AND PRESSURE**

1. Defective motor
2. Pump impeller has become loose or is defective.
3. Debris in impeller

## **WINTER STORAGE**

The entire water system should be protected from freezing during winter storage. Pump should be drained, using the following directions:

- Turn on power to pump.
- Open all faucets and drains and allow pump to empty water tank and intake line. The pump will automatically turn off.
- Turn off power to pump. Remove the priming and drain plugs.
- Allow time for the water heater to empty.
- Reinstall the drain plug, using pipe sealant not Teflon (PTFE) type tape on threads, and leave outlets open.
- Reinstall the fill plug. Do not use sealant or tape on the threads.

The system is now dry and ready for winter storage.

An alternate method is to use potable water system anti-freeze solution.

**⚠ WARNING DO NOT USE AUTOMOTIVE TYPE ANTI-FREEZE. IT IS POISONOUS AND MAY CAUSE ILLNESS OR DEATH.**



# EXPLODED VIEW

WIRING OMITTED  
FOR CLARITY

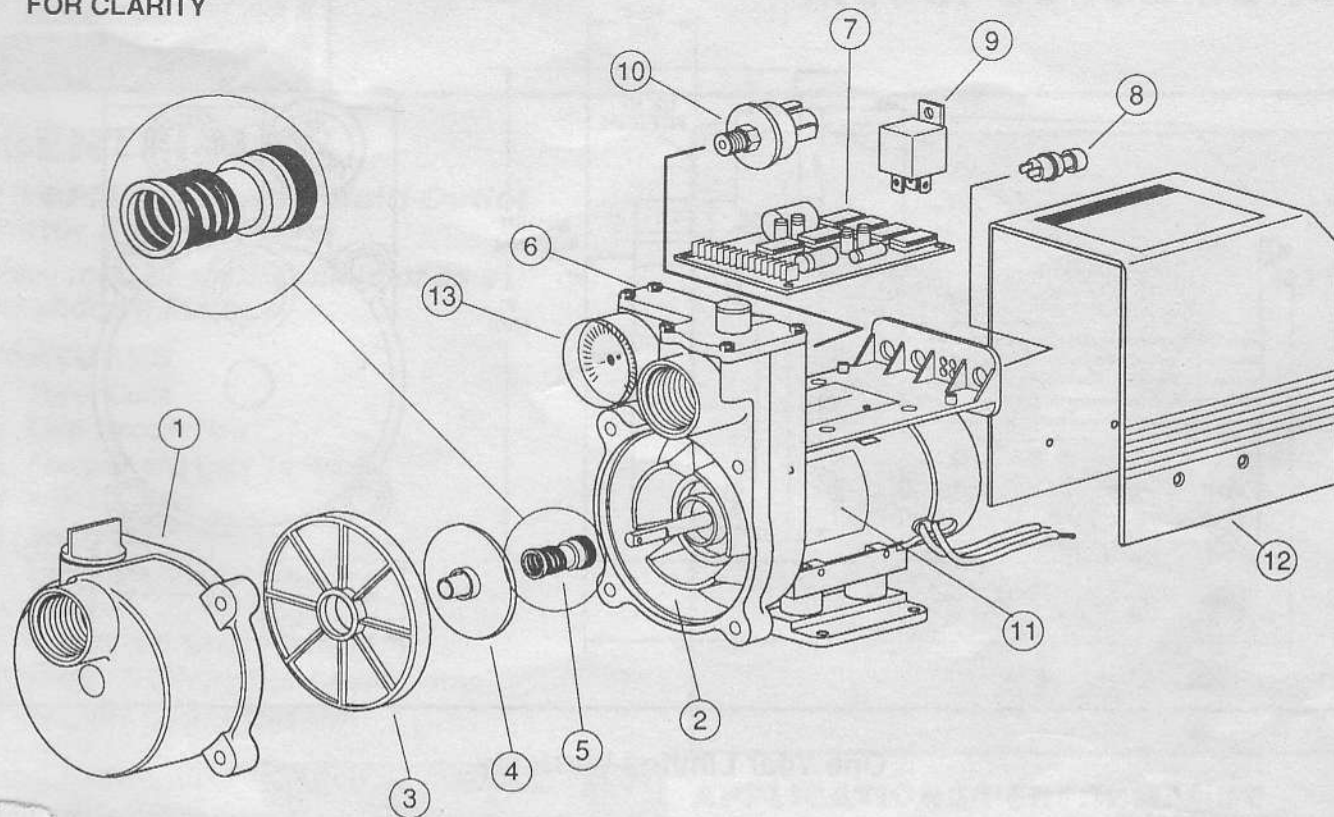

## PARTS LIST

KEY#	DESCRIPTION	QTY	PART NUMBER
1	Body (front)	1	30453-1000
2	Body (rear)	1	30454-1000
3	Diffuser	1	30452-1000
4	Impeller	1	30451-1000
5	Shaft Seal Assembly with Body O-ring	1	18753-0465
6	Flow Switch w/Cover Mag Disc & O-ring	1	30467-1000
7	Circuit Board	1	30443-1000
8	Reset Switch	1	18753-0466
9	Relay	1	18753-0467
10	Pressure Switch	1	18753-0468
11	Motor - 12 Volt dc	1	30446-1012
	24 Volt dc	1	30446-1024
12	Cover	1	30468-1000
13	Pressure Gauge	1	30472-1000
	(Not Shown)		
	Optional Alarm with cable	1	30440-1000
	Check Valve	1	30473-1000
	Strainer	1	36300-1000

**DIMENSIONAL DRAWINGS**  
inches (millimetres)

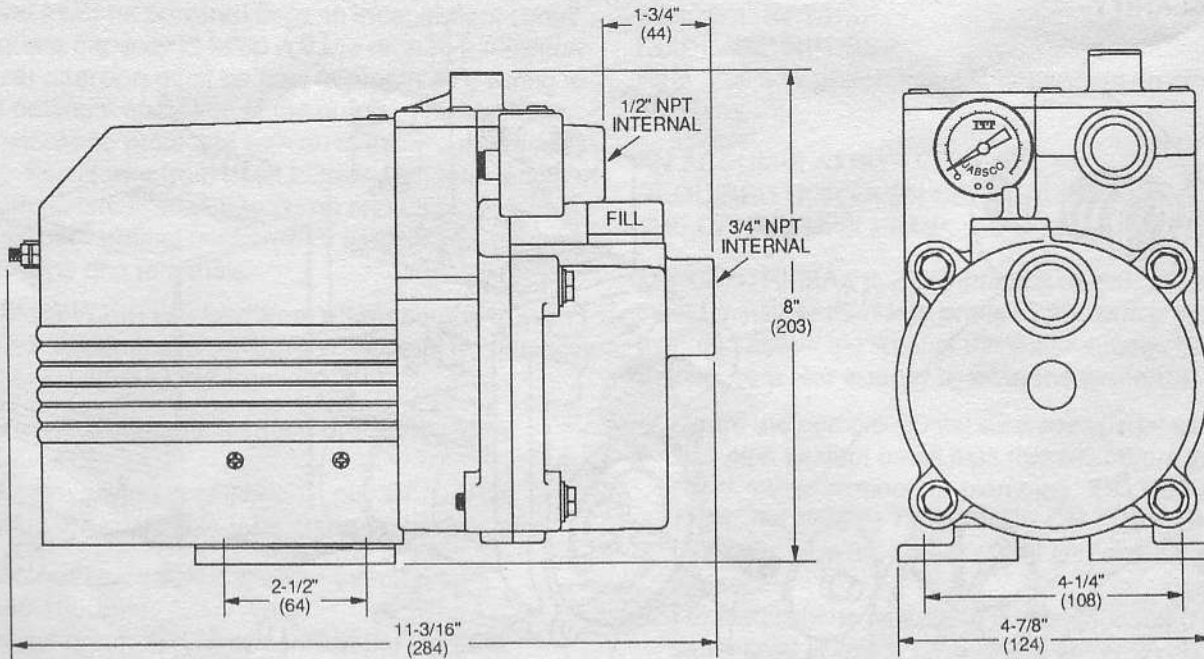

**One Year Limited Warranty**

**A. LIMITED WARRANTY:** ITT warrants that at the time of shipment, the products manufactured by ITT and sold hereunder shall be in conformity with applicable written specifications and descriptions referred to or set forth herein, free from defects in material and workmanship, merchantable, and suitable for a particular purpose, provided such is implied by State law under the circumstances of this sale.

**B. WARRANTY ADJUSTMENT:**

1. ITT agrees to repair or furnish a replacement for, but not to remove or install, any product or component thereof which, within one (1) year from date of purchase, shall upon test and examination by ITT prove defective within the above warranty. Receipt verifying purchase date is required to obtain adjustment.
2. Buyer shall notify ITT of any defect within this warranty no later than ninety (90) days after the defect is discovered.
3. No product will be accepted for return or replacement without the prior written authorization of ITT. Upon such authorization, and in accordance with instructions from ITT, the product will be returned to ITT, shipping charges prepaid by Buyer. Products returned to ITT will be addressed as follows:

**ITT JABSCO**  
1485 Dale Way  
Costa Mesa, California 92626-3998

Or to such alternate locations as may be designated on the product, its container, or this sheet.  
Repair or replacement made under this warranty will be shipped prepaid to Buyer.

**C. EXCLUSIONS FROM WARRANTY AND LIMITATION OF LIABILITY:**

1. The foregoing warranty is limited solely as set forth herein and applies only for the period designated above.

2. ITT SHALL NOT BE LIABLE FOR ANY LOSS, DAMAGE, SPECIAL OR CONSEQUENTIAL DAMAGE OF ANY KIND, WHETHER BASED UPON WARRANTY, CONTRACT, NEGLIGENCE, OR STRICT LIABILITY ARISING IN CONNECTION WITH THE SALE, USE, OR REPAIR OF THE PRODUCT.
3. THE MAXIMUM LIABILITY OF ITT IN CONNECTION WITH THIS WARRANTY SHALL NOT IN ANY CASE EXCEED THE CONTRACT PRICE FOR THE PRODUCT CLAIMED TO BE DEFECTIVE OR UNSUITABLE.
4. This warranty does not extend to any product manufactured by ITT which has been subjected to misuse, neglect, accident, improper installation, or use in violation of instructions furnished by ITT.
5. This warranty does not extend to or apply to any unit which has been repaired or altered at any place other than ITT's factory, or by persons not expressly approved by ITT, nor to any unit the serial number, model number, or identification of which has been removed, defaced or changed.
6. Components manufactured by any supplier other than ITT shall bear only that warranty made by the manufacturer of that product.
7. This warranty applies to products defined as "consumer products" by the Consumer Product Warranties Act as from time to time amended.

**D. CONSUMER RIGHTS:** This warranty gives you specific legal rights, and you may have other rights which vary from state to state. Some states do not allow exclusion or limitation of damages.

**STANDARD WARRANTY:** If the products manufactured and sold hereunder are not Consumer Products, the warranty extended to Buyer shall be as set forth in subparagraphs (A), (B), and (C), EXCEPT THAT ALL EXPRESS OR IMPLIED WARRANTIES OR MERCHANTABILITY OR SUITABILITY FOR ANY PARTICULAR PURPOSE ARE EXCLUDED.

**ITT Jabsco**

ITT Fluid Technology Corporation  
1485 Dale Way, P.O. Box 2158, Costa Mesa, CA 92628-2158  
Tel: (714) 545-8251; Fax: (714) 957-0609  
Bingley Road, Hoddesdon, Hertfordshire EN11 0BU England  
Tel: 0992-467191; Tlx: 263251 G; Fax: 0992-467132