

JABSCO

Model 30430-SERIES

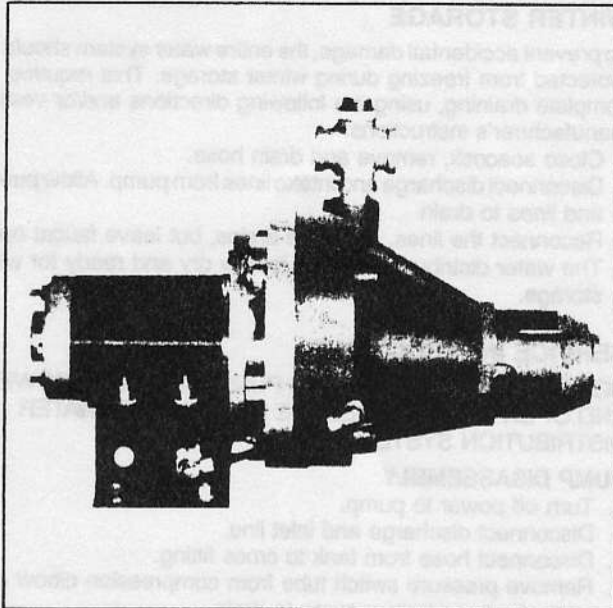

RAW WATER WASHDOWN PUMP

FEATURES

- High Capacity
- Stainless Steel Hardware
- 1" Check Valve Included
- Heavy Duty Construction

SPECIFICATIONS

Flow:	Up to 10 GPM
Pump:	Jet Type Centrifugal
Motor:	1/2 HP Permanent Magnet
Vertical Suction	
Lift:	6' (1,8 m)
Ports:	1" NPT Inlet, 3/4" NPT Outlet
Dimensions:	18" (457mm) x 12" (305mm) x 8 3/4" (222mm)
Weight:	29 lbs. (13,2 kg)

Meets Title 33, Chapter 1, Part 183, Subpart I, United States Coast Guard Electrical Regulations, including paragraph 183.410 covering ignition protection.

Model 30430-SERIES

APPLICATION/PERFORMANCE

Model 30430 Washdown pump is ideal for anchor and general deck washdown. The heavy duty unit is a jet type centrifugal pump capable of supplying up to 10 GPM at open flow.

Meets Title 33, Chapter 1, Part 183, Subpart I, United States Coast Guard Electrical Regulations, including paragraph 183.410 covering ignition protection.

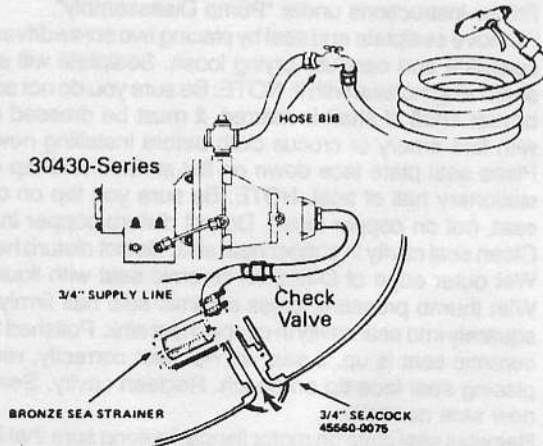

INSTALLATION

WARNING: DO NOT OPERATE WITH SCREWS REMOVED FROM MOTOR CASE WHICH MOUNTS MOTOR TO BRACKET. EXPLOSION RESULTING IN PERSONAL INJURY, DEATH OR PROPERTY DAMAGE MAY OCCUR, CASE OPENINGS MUST BE SEALED TO AVOID EXPLOSION AND MAINTAIN IGNITION PROTECTION RATING. Mount raw water washdown unit on solid, level surface with four (4) 3/8 bolts. Install check valve as close to hull inlet or seacock as possible. **IMPORTANT:** Use teflon tape for making all threaded connections to pump itself. Do not use pipe joint compounds on pump; they can react with plastic in pump compound.

For maximum performance, inlet lines must be 1" ID non-collapsible or reinforced hose. The seacock and plumbing fittings must be 1" ID. a bronze sea strainer with 1" hose fittings should be installed to protect check valve from debris. Maximum supply length should be limited to 20 feet (6m). Double clamp all connections. Avoid any kinks or fittings which could cause excessive restriction.

Model	Voltage	Amp. Draw Nom.	Circuit Breaker*	Open Flow	Pressure (Nom.)	
					Cut-in	Cut-off
30430-0012	12 Vdc	36	50 Amp	9.5 GPM	18 PSI	30 PSI
30430-0024	24 Vdc	25	35 Amp	10 GPM	26 PSI	40 PSI
30430-0032	32 Vdc	20	25 Amp	10 GPM	26 PSI	40 PSI

* Manual Reset

WIRING

PROPER POLARITY MUST BE MAINTAINED TO ENSURE CORRECT OPERATION OF PUMP. REVERSE POLARITY WILL DAMAGE PUMP. IMPELLER IS ATTACHED TO SHAFT AND WILL LOOSEN IF OPERATED IN REVERSE ROTATION.

Due to the large flow of water, these units have a high amperage draw and require an electrical circuit independent of all other accessories. Particular attention must also be paid to proper size wiring to ensure optimum operation of unit. For longer runs, increase wire size in accordance with wire selection chart. For proper electrical connections, refer to the polarity label (+ -) on unit, and diagram below.

Install rubber terminal boot on wire leads before attaching and crimping ring terminals. Connect ground wire, if used, to green grounding terminal using ring terminal. Connect positive (+) lead from power source to positive terminal and negative (-) lead from battery ground to negative terminal.

WIRING DIAGRAM

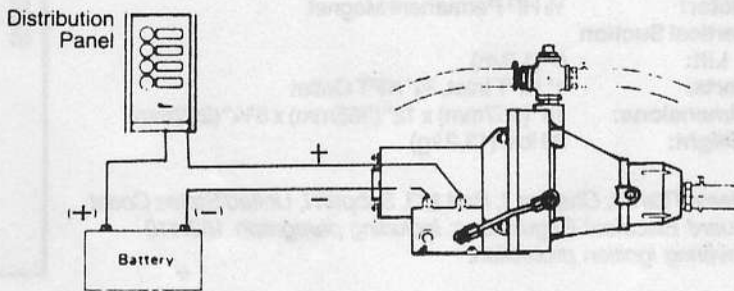

Wire size chart (AWG-COPPER) @ 3% V Drop
Length of circuit in feet (sum of Positive & Negative wire lengths)

VOLT	0-20'	21-30'	31-40'	41-50'	51-60'
12	# 6	# 4	# 2	# 2	# 1
24	#10	# 8	# 6	# 6	# 6
32	#12	#10	#10	# 8	# 8

OPERATION

IMPORTANT: NEVER RUN PUMP DRY. TO RUN PUMP WITHOUT WATER MAY DAMAGE SEALS OR OTHER INTERNAL PARTS. TO PREVENT DAMAGE TO INTERNAL PARTS, FILL PUMP WITH WATER BEFORE STARTING.

- Remove priming plug located on top of system and fill pump and suction pipe with water.
- Replace priming plug, using teflon tape on plug threads.
- Open seacock to plumbing inlet.
- Open valve and nozzle on washdown hose.
- Turn on power to pump— DO NOT run pump for more than 60 seconds. Unit should pump water; if not, repeat above steps. On first use of pump, it may be necessary to reprime pump two or three times.
- Close valve when it begins to flow. Bleed air from all raw water valves.
- Observe the pump. Check to be sure pump stops soon after the valve is closed (about 30 seconds).
- Pump is now ready for automatic operation. It will start when system pressure drops to 18 PSI (12V) [26 PSI (24/32V)] and shut off when system pressure reaches 30 PSI (12 V) [40 PSI (24/32V)].
- Turn off power to pump and close seacock when vessel is left unattended.

CAUTION: Motor case will get hot. Prolonged contact during operation may cause a burn.

MAINTENANCE

It is recommended, as with other major systems aboard, that periodic inspections are made of the Jabsco Washdown System. The following checklist may be helpful:

- Inspect sea water strainer for debris which could restrict suction flow.
- Observe mechanical function of pump.
- No lubrication to unit is necessary. The shaft seal in the pump is water lubricated and self-adjusting.

WINTER STORAGE

To prevent accidental damage, the entire water system should be protected from freezing during winter storage. This requires complete draining, using the following directions and/or vessel manufacturer's instructions:

- Close seacock, remove and drain hose.
- Disconnect discharge and intake lines from pump. Allow pump and lines to drain.
- Reconnect the lines, close the drains, but leave faucet open. The water distribution system is now dry and ready for winter storage.

SERVICE INSTRUCTIONS

NOTICE: BEFORE SERVICING PUMP, TURN OFF POWER AND OPEN VALVE TO RELIEVE PRESSURE IN WATER DISTRIBUTION SYSTEM.

PUMP DISASSEMBLY

1. Turn off power to pump.
2. Disconnect discharge and inlet line.
3. Disconnect hose from tank to cross fitting.
4. Remove pressure switch tube from compression elbow on pump body and allow pump to drain.
5. Remove (4) four hex nuts which hold pump body to the motor.
6. Separate pump body from motor. Note: Seal plate, impeller, diffuser and pad remain attached to motor.
7. Remove (2) two hex head screws fastening diffuser to seal plate; remove diffuser.
8. Place screwdriver in slot on back of motor and hold firmly while turning impeller counterclockwise (when facing impeller) to remove.

REPLACING SHAFT SEAL

1. Follow instructions under "Pump Disassembly".
2. Remove sealplate and seal by placing two screwdrivers under sealplate and carefully prying loose. Sealplate will slide off shaft bringing seal with it. NOTE: Be sure you do not scratch or mar shaft; if shaft is marred, it must be dressed smooth with fine emery or crocus cloth before installing new seal.
3. Place seal plate face down on flat surface and tap out stationary half of seal. NOTE: Be sure you tap on ceramic seat, not on copper insert. Do not disturb copper insert.
4. Clean seal cavity in copper heat sink. Do not disturb heat sink.
5. Wet outer edge of O-ring on ceramic seat with liquid soap.
6. With thumb pressure, press ceramic seal half firmly and squarely into seal cavity in copper heat sink. Polished face of ceramic seat is up. If seal will not seat correctly, remove, placing seal face up on bench. Reclean cavity. Seal should now seat correctly.
7. Reinstall seal plate on motor flange, making sure that it is right side up.
8. Apply liquid soap sparingly to inside diameter of rotating seal member.
9. Slide rotating seal member (carbon face first) onto shaft until rubber drive ring hits shaft shoulder. Note: Be sure not to nick or scratch carbon face of seal when passing it over threaded shaft end or shaft shoulder. The carbon surface must remain clean or short seal life will result.
10. Hold motor securely with slotted screwdriver on back of motor and screw impeller onto motor shaft. Tightening impeller will automatically locate seal in correct position.
11. Reinstall diffuser on sealplate with two screws.
12. Install new rubber pad to top of diffuser.
13. Follow instruction under "Pump Reassembly".

PUMP REASSEMBLY

1. Install new O-ring gasket on seal plate.
2. Pick up a small amount of liquid soap on one finger and spread evenly over O-ring gasket for lubrication during reassembly. Be careful not to nick or tear O-ring.
3. Replace motor onto pump body. Be sure rubber pad stays in place on top of diffuser. Tighten four hex nuts and lockwashers snugly 35-45 inch/lbs. torque. Do not overtighten.
4. Reconnect pressure switch tube and hose from tank to cross fittings.
5. Reconnect discharge and inlet lines.
6. Reconnect motor wiring.
7. Prime pump according to instruction; see Operation.
8. Check for leaks.

MOTOR REPLACEMENT

1. Turn off power to pump.
2. Follow instructions under "Pump Disassembly" to disconnect pump from motor (steps 1 - 8).
3. Disconnect power leads from back of motor. Note: Mark wires for correct reassembly.
4. Remove two No. 1/4-20 screws located under motor mounting bracket.
5. Replace motor.
6. To reinstall motor, reverse steps 3 - 5.
7. Follow instructions under "Pump Reassembly" (steps 3 - 8).

EXPLODED VIEW

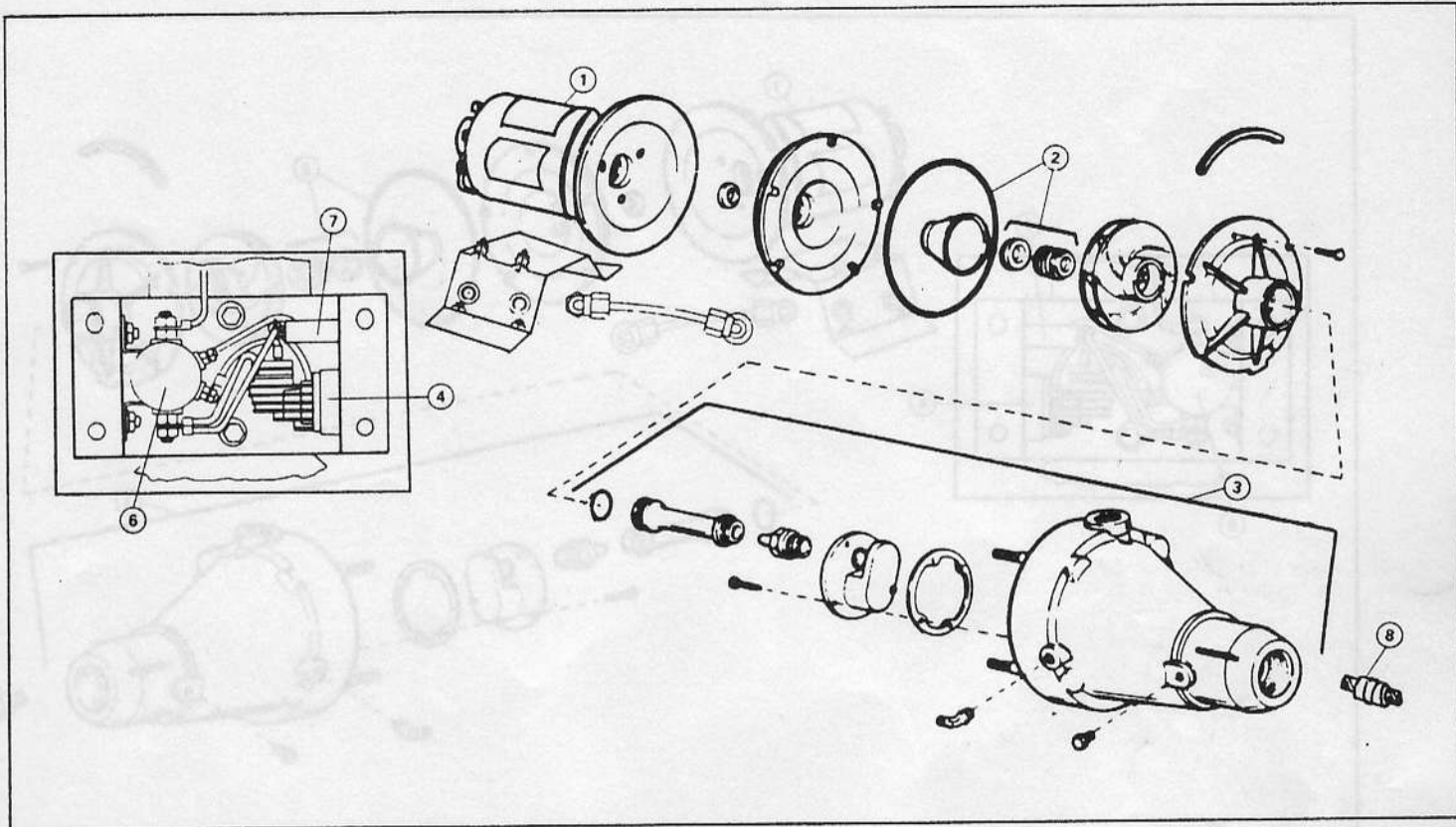

REPLACEMENT PARTS LIST

KEY	DESCRIPTION	QTY.	PART #
1	Motor 12 Vdc	1	18753-0146
	Motor 24 Vdc	1	18753-0147
	Motor 32 Vdc	1	18753-0148
2	Seal / O-ring Kit	1	18753-0149
3	Pump Assembly	1	18753-0150
4	Pressure Switch (24 & 32 V)	1	30434-1000
	Pressure Switch (12V)	1	30434-1001
5	Micro Switch (Not Shown)	1	18753-0141

KEY	DESCRIPTION	QTY.	PART #
6	Solenoid 12V	1	18753-0151
	Solenoid 24V	1	18753-0152
	Solenoid 32V	1	18753-0153
7	Circuit Breaker 12V	1	18753-0154
	Circuit Breaker 24V	1	18753-0155
	Circuit Breaker 32V	1	18753-0156
8	Check Valve 1"	1	18753-0157

DIMENSIONAL DRAWING

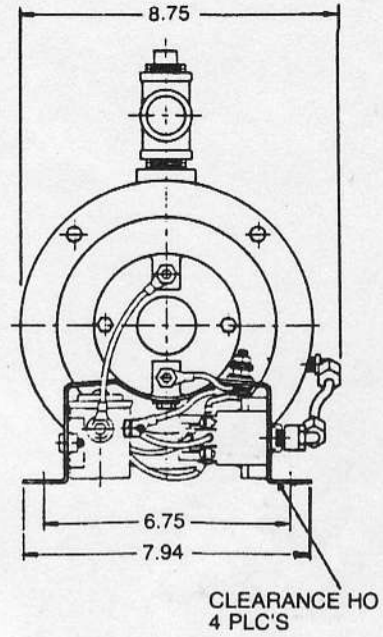
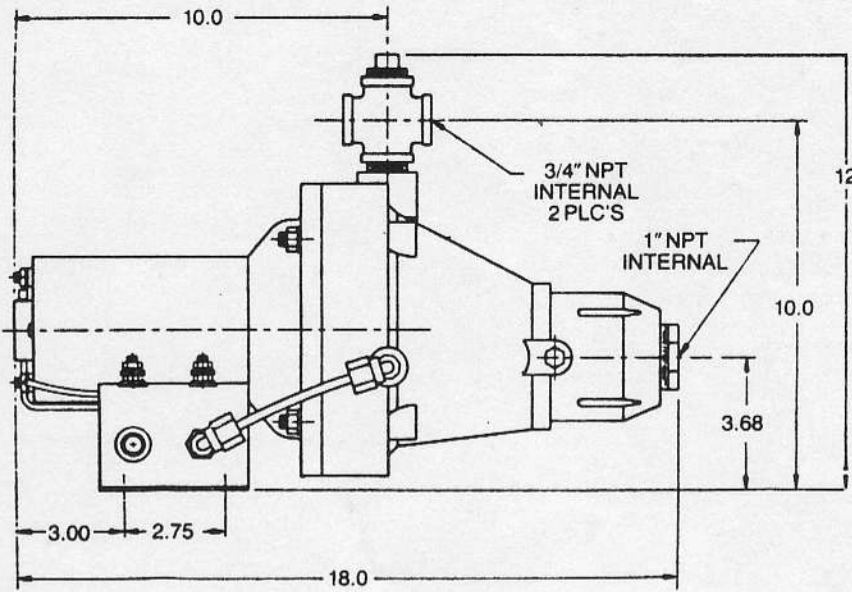

ELECTRICAL WIRING DIAGRAM

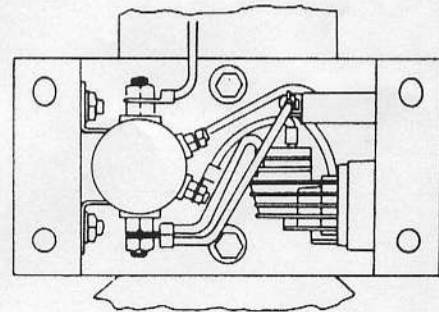
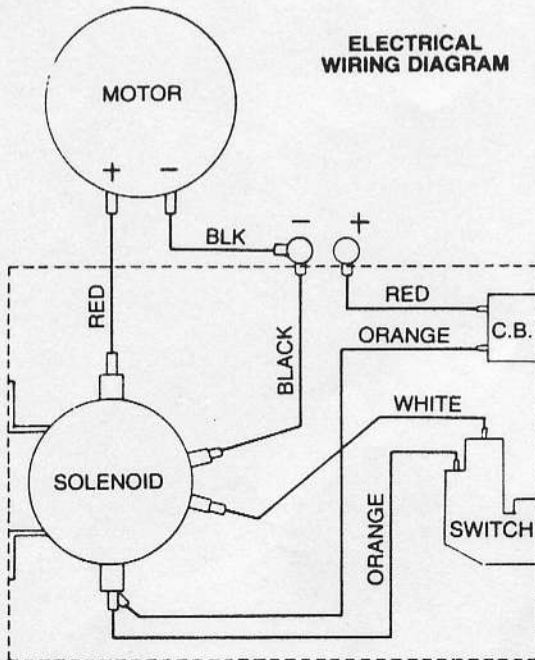

THE PRODUCTS DESCRIBED HEREIN ARE SUBJECT TO THE JABSCO ONE YEAR LIMITED WARRANTY, WHICH IS AVAILABLE FOR YOUR INSPECTION UPON REQUEST.