

JABSCO® PUMPS

Self-Priming Pumps

MODEL: 3010 - Series

Product Data

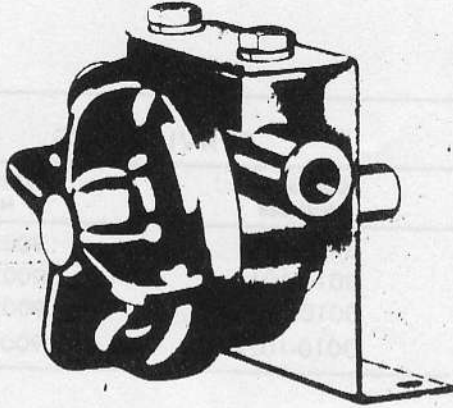

3010-1011

DESIGN FEATURES

Body:	Phenolic Type Plastic
Impellers:	Neoprene, Nitrile or Viton
Shafts:	Stainless Steel, Hastelloy, or Titanium
Seal:	Lip Type
Bearing:	Filled Teflon - Replaceable
Ports:	5/8 ID hose — slip on ports
Weight:	8 oz. (approximately) (227 grams)

VARIATIONS AVAILABLE

Model	Variation Incorporated		
3010-1011	Stainless Steel Shaft Neoprene Impeller	3010-1024	Hastelloy "B" Shaft Viton Impeller, Seal & "O" Ring
3010-1013	Stainless Steel Shaft Nitrile Impeller	3010-1151	Titanium Shaft Neoprene Impeller
3010-1014	Stainless Steel Shaft Viton Impeller, Seal & "O" Ring	3010-1153	Titanium Shaft Nitrile Impeller
3010-1021	Hastelloy "B" Shaft Neoprene Impeller	3010-1154	Titanium Shaft Viton Impeller, Seal & "O" Ring
3010-1023	Hastelloy "B" Shaft Nitrile Impeller		

APPLICATIONS

INDUSTRIAL: Designed for: Carboy and drum transfer, hazardous chemical transfer and recirculation, recirculation of de-scaling compounds through refrigeration and condenser coils, printed circuit etching, general laboratory transfer, photographic fixes and developers, barium transfer, transfer ammonia on blueprint machines, silver recovery, demineralized and distilled water. See JABSCO Pump "Chemical Resistance Table" which has been prepared to help you select the

most suitable impeller and pump material.

SHAFT MATERIAL SELECTION

The only metallic parts in the 3010 series are the shaft and drive pin. These two parts may be varied to cover a wide range of specialized chemical applications. For complete recommendations, consult Chemical Resistance Table.

316 SS—Type 18-8 stainless steel. Possesses excellent corrosion resistance to a wide range of chemical solutions including ammonia,

barium, many cyanide solutions, silver nitrate, photographic solutions including fix and developer.

Hastelloy B — (nickel-molybdenum-iron alloy). Possesses excellent resistance to certain highly corrosive fluids such as hydrochloric and muriatic acids, fluoroboric acid, oxalic acid.

Titanium — Outstanding resistance over a wide range of highly corrosive fluids including ferric chloride, sulfamic acid, copper chloride.

In the past Jabsco has offered the 3010 series with molded in carbon bearings. These are no longer available. For replacement bodies or end covers, order them with Teflon bearings as listed in parts list. All parts are interchangeable between old and new models.

JABSCO PRODUCTS **ITT**

Form 43000-0185 Rev. 6/78

MODEL: 3010 SERIES

EXPLODED VIEW

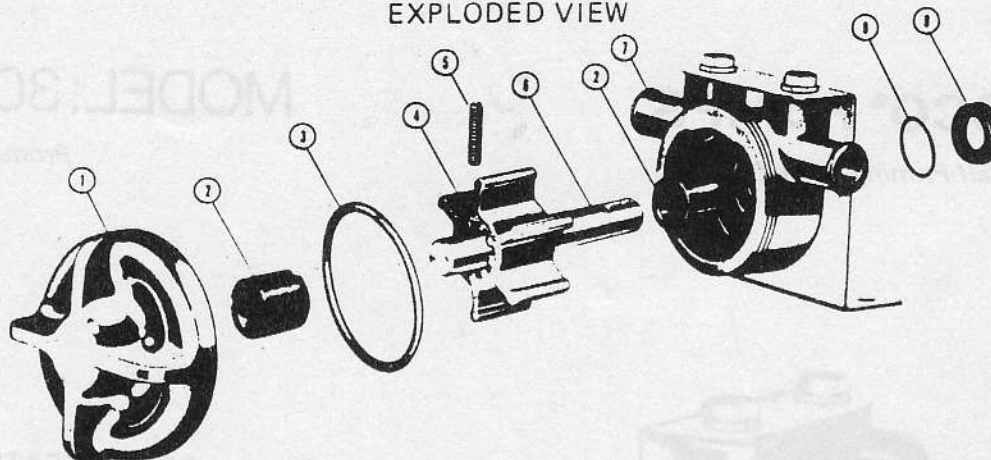

PARTS LIST

Key	Description	Qty. Req.	Part No.
1	End Cover with Teflon Bearing	1	8187-0000
2	Teflon Bearing (Replaceable)	2	3625-1150
3	"O" Ring (End Cover)	1	92000-0590 Standard Viton 92000-0790
4	*Impeller	1	3398-0001 Neoprene Nitrile 3398-0003 Viton 3398-0004
5	*Pin (Impeller)	1	91029-0070 Stainless Steel Hastelloy "B" 92850-0030 Titanium 3452-0150
6	Shaft	1	1983-0010 Stainless Steel Hastelloy "B" 1983-0020 Titanium 1983-0150
7	Body with Bearing and Bracket	1	3015-1150
8	*Seal	1	93000-0010 Standard Viton 93000-0030
9	"O" Ring (Seal)	1	92000-0120 Standard Viton 92000-0800
Not Shown	End Cover Wrench	1	7110-0000

* Parts supplied in service kit.

SERVICE KITS

PUMP MODEL NUMBER	SERVICE KIT NUMBER
3010-1011	90026-1011
3010-1013	90026-1013
3010-1014	90026-1014
3010-1024	90026-1024

HEAD CAPACITY TABLE

TOTAL HEAD				500 RPM			1160 RPM			1750 RPM		
Lbs. per Sq. In.	Kg./cm. 2	Ft. of Water	Meters of Water	GPM	l/min.	H/P	GPM	l/min.	H/P	GPM	l/min.	H/P
4.3	0.3	10	3.0	1.3	4.9	1/6	3.5	13.2	1/6	5.8	22.0	1/4
8.7	0.6	20	6.1	.5	1.9	1/6	2.5	9.5	1/5	5.0	18.9	1/4
13.0	0.9	30	9.1	-	-	-	1.4	5.3	1/4	3.8	14.4	1/4

Progressively longer life may be expected as operating speeds are reduced. Capacitor type motors are recommended.

Table shows approximate Head-Flow for new pump is U.S. gallons per minute with neoprene impeller. Capacities reduced approximately 10% for nitrile and viton impellers.

SERVICE INSTRUCTIONS
DISASSEMBLY

- Unscrew end cover with 7110 - 0000 wrench. USE CARE NOT TO BREAK RIBS.
- Withdraw impeller and shaft assembly.
- Remove impeller to shaft screw, then slide impeller off the shaft.
- Using a hooked wire, deform seal and remove from body. Use care not to mar or scratch seal bore.

NOTE: Inspect all parts for wear or damage and replace if necessary.

ASSEMBLY

- Lubricate seal. Deform and install in body. Make certain seal is properly seated after installation. Remove bearing. Install 'O' Ring into cup of seal. Replace bearing in body.
- Slide impeller on shaft, aligning holes in impeller and shaft.
- Press in impeller drive screw.
- Lightly oil drive end of shaft and install in body with rotating motion. Be sure shaft is free of burrs.
- Install "O" ring in cover.
- Screw cover onto body. TIGHTEN HAND TIGHT ONLY.

JABSCO PRODUCTS ITI

Marine and Recreation Components Division
International Telephone and Telegraph Corporation
1485 Dale Way, Costa Mesa, California 92626
Telephone (714) 545-8251