

JABSCO

Model 3010-SERIES

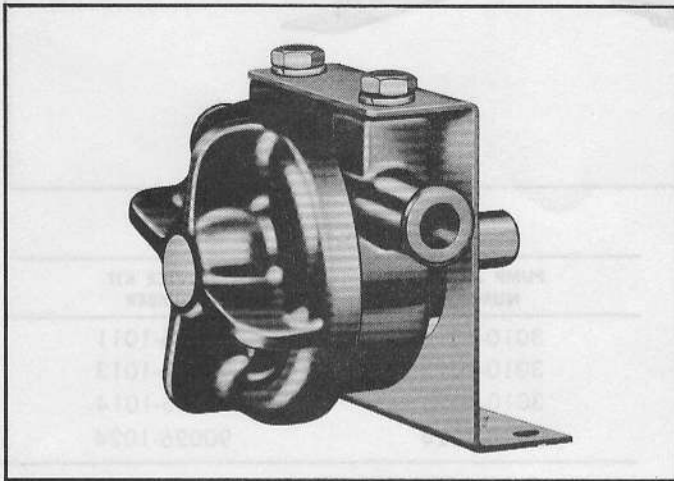

3010-1011

SELF-PRIMING PUMPS

FEATURES

Body:	Phenolic Type Plastic
Impellers:	Neoprene, Nitrile or Viton
Shafts:	Stainless Steel, Hastelloy, or Titanium
Seal:	Lip Type
Bearing:	Filled Teflon - Replaceable
Ports:	5/8 ID hose - slip on ports
Weight:	8 oz (227 grams) approx.

Model 3010-SERIES

VARIATIONS AVAILABLE

Model	Variation Incorporated	Model	Variation Incorporated
3010-1011	Stainless Steel Shaft Neoprene Impeller	3010-1024	Hastelloy "B" Shaft Viton Impeller, Seal & O-ring
3010-1013	Stainless Steel Shaft Nitrile Impeller	3010-1151	Titanium Shaft Neoprene Impeller
3010-1014	Stainless Steel Shaft Viton* Impeller, Seal & O-ring	3010-1153	Titanium Shaft Nitrile Impeller
3010-1021	Hastelloy "B" Shaft Neoprene Impeller	3010-1154	Titanium Shaft Viton Impeller, Seal & O-ring
3010-1023	Hastelloy "B" Shaft Nitrile Impeller		

APPLICATIONS

INDUSTRIAL: Designed for: Carboy and drum transfer, hazardous chemical transfer and recirculation, recirculation of descaling compounds through refrigeration and condenser coils, printed circuit etching, general laboratory transfer, photographic fixes and developers, barium transfer, transfer ammonia on blueprint machines, silver recovery, demineralized and distilled water. See Jabsco Chemical Resistance Table (available upon request from ITT Jabsco), which has been prepared to help you select the most suitable impeller

and pump material.

SHAFT MATERIAL SECTION

The only metallic parts in the 3010 series are the shaft and drive pin. These two parts may be varied to cover a wide range of specialized chemical applications. For complete recommendations, consult Chemical Resistance Table (which is available upon request from ITT Jabsco).

316 SS - Type 18-8 stainless steel. Possesses excellent corrosion resistance to a wide range of chemical solutions including

ammonia, barium, many cyanide solutions, silver nitrate, photographic solutions including fix and developer.

Hastelloy B - (nickel-molybdenum-iron alloy). Possesses excellent resistance to certain highly corrosive fluids such as hydrochloric and muriatic acids, fluoroboric acid, oxalic acid.

Titanium - Outstanding resistance over a wide range of highly corrosive fluids including ferric chloride, sulfamic acid, copper chloride.

In the past Jabsco has offered the 3010 series with molded in carbon bearings. These are no longer available. For replacement bodies or end covers, order them with Teflon* bearings as listed in parts list. All parts are interchangeable between old and new models.

Teflon* is a trademark of E. I. Du Pont de Nemours and Company.

Viton* is a trademark of E. I. Du Pont de Nemours and Company.

EXPLODED VIEW

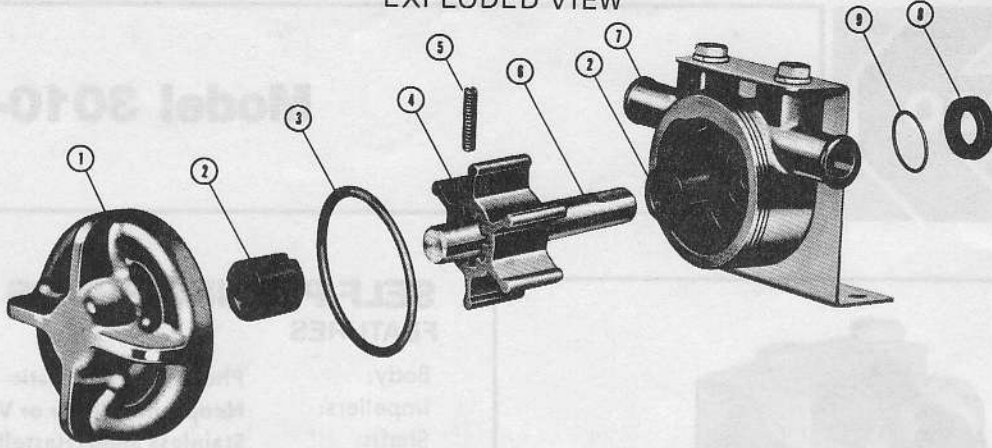

PARTS LIST

Key	Description	Qty. Req.	Part No.
1	End Cover with Teflon Bearing	1	8187-0000
2	Teflon Bearing (Replaceable)	2	18700-0000
3	* O-ring (End Cover)	1	
	Standard		92000-0590
	Viton		92000-0790
4	* Impeller	1	
	Neoprene		3398-0001
	Nitrile		3398-0003
	Viton		3398-0004
5	* Pin (Impeller)	1	
	Stainless Steel		91029-0070
	Hastelloy "B"		92850-0030
	Titanium		3452-0150
6	Shaft	1	
	Stainless Steel		1983-0010
	Hastelloy "B"		1983-0020
	Titanium		1983-0150
7	Body with Bearing and Bracket	1	3015-1150
8	* Seal	1	
	Viton		93000-0030
9	* O-ring (Seal)	1	
	Standard		92000-0120
	Viton		92000-0800

* Parts supplied in service kit.

SERVICE KITS

PUMP MODEL NUMBER	SERVICE KIT NUMBER
3010-1011	90026-1011
3010-1013	90026-1013
3010-1014	90026-1014
3010-1024	90026-1024

HEAD CAPACITY TABLE

TOTAL HEAD			500 RPM			1160 RPM			1750 RPM		
lbs per sq in.	kg/cm ²	ft of water	GPM	l/min	hp	GPM	l/min	hp	GPM	l/min	hp
4.3	0,3	10	1.3	4,9	1/6	3.5	13,2	1/6	5.8	22,0	1/4
8.7	0,6	20	.5	1,9	1/6	2.5	9,5	1/5	5.0	18,9	1/4
13.0	0,9	30	—	—	—	1.4	5,3	1/4	3.8	14,4	1/4

Progressively longer life may be expected as operating speeds are reduced. Capacitor start type motors are required.

Table shows approximate Head-Flow for new pump in U.S. gallons per minute with neoprene impeller. Capacities reduced approximately 10% for Nitrile and Viton impellers.

SERVICE INSTRUCTIONS
DISASSEMBLY

- Unscrew end cover. USE CARE NOT TO BREAK RIBS.
- Withdraw impeller and shaft assembly.
- Remove impeller to shaft screw, then slide impeller off the shaft.
- Using a hooked wire, remove bearing from body. Remove O-ring from seal. Deform seal and remove from body. Use care not to mar or scratch seal bore.

NOTE: Inspect all parts for wear or damage and replace if necessary.

ASSEMBLY

- Deform seal and install in body with lips facing impeller bore. Make sure seal is seated in its body groove. Remove bearing. Install O-ring into cup of seal and lubricate inner seal lip with water pump grease. Replace bearing in body.
- Slide impeller on shaft, aligning holes in impeller and shaft.
- Press in impeller drive screw.
- Lightly oil drive end of shaft and install in body with rotating motion. Be sure shaft is free of burrs. Be sure seal lip is not deformed by shaft.
- Install O-ring in cover.
- Screw cover onto body. TIGHTEN HAND TIGHT ONLY.

THE PRODUCTS DESCRIBED HEREIN ARE SUBJECT TO THE JABSCO ONE YEAR LIMITED WARRANTY, WHICH IS AVAILABLE FOR YOUR INSPECTION UPON REQUEST.

ITT Jabsco
ITT Fluid Technology Corporation
1485 Dale Way, P.O. Box 2158
Costa Mesa, CA 92628-2158
Telephone: (714) 545-8251