



**PAR**

# Manual Toilets

## Installation, Operation and Maintenance Instructions

### MODELS

- 29090-0000 MANUAL TOILET, STANDARD BOWL
- 29120-0000 MANUAL TOILET, LARGE BOWL

### APPLICATIONS

YOU MAY install PAR Standard and Large Bowl manually operated marine toilets in both power and sailing craft, either above or below the waterline, for use on sea, river, lake or canal.

- Your installation may discharge the waste either overboard (*provided that your national and local regulations allow this*), or into a treatment system or an on-board holding tank (U.S.C.G Marine Sanitation Devices Type I, II and III).

**CAUTION:** PAR manual toilets are designed specifically for marine use. Consult ITT Jabsco for advice about possible non-marine applications.

### SPECIFICATIONS

#### DESIGN

- Double-acting piston pump
- Renewable external seal housing and piston rod guide
- Automatic vacuum breaker operated by flush control lever
- Aortic joker valve combines full 38mm (1½in) bore with automatic back-flow prevention
- Reversible pump mounting allows re-assembly for left handed installation

#### MATERIALS

- Seat and cover moulded in wood, with baked enamel coating, fitted with plastic bolts and hinges, and zinc plated screws
- Bowl moulded in glazed ceramic
- Pump and base moulded in high impact ABS plastic with selected parts in acetal resin, fitted with stainless steel fastenings, brass weights, and neoprene seals and gaskets

#### PERFORMANCE

- Flushing pump self-primers from dry up to 1 metre (3ft) below inlet hose tail
- Waste pump discharges up to 3 metres (9ft) above outlet elbow

#### DIMENSIONS

- Refer to Dimensional Drawing on back page

**JABSCO®**  
MARINE PRODUCTS

# INSTALLATION INSTRUCTIONS

## INTRODUCTION

THE TOILET is just one part of a system. Correct installation of the whole system is essential if you want the toilet to perform properly, operate reliably and safely, and give satisfactory length of life.

### HAZARD RISKS: THROUGH-HULL FITTINGS

If the installation of the toilet results in it being connected to ANY through-hull fitting that may possibly be below the waterline at ANY time whether when the craft is at rest or underway and heeling, rolling or pitching you MUST install the toilet in accordance with these INSTALLATION INSTRUCTIONS.

If you do not, water may flood in, causing the craft to sink, which may result in Loss of Life. FOLLOW THESE INSTRUCTIONS!

### ACCIDENTAL DAMAGE

If the toilet is connected to ANY through-hull fittings and if the toilet or the pipework is damaged, water may flood in causing the craft to sink, which may result in Loss of Life.

Therefore, if you are making connections between the toilet and ANY through hull fittings that may possibly be below the waterline at ANY time, fullbore seacocks MUST be fitted to those hull fittings, to allow them to be shut off.

The seacocks MUST also be positioned where they are easily accessible to all users of the toilet. If, for any reason, it is not possible to do this, then secondary full-bore marine quality valves MUST be fitted to the hoses where they are easily accessible. USE SEACOCKS!

CAUTION: Use lever operated, full-bore marine seacocks and valves. The use of screw-down gate valves is not recommended.

### PIPEWORK BECOMES LOOSE

If the toilet is connected to ANY through-hull fittings and if the pipework becomes disconnected either from a through-hull fitting or seacock, or from the toilet or any secondary valve, water may flood in and may cause the craft to sink, which may result in Loss of Life.

Therefore the ends of ALL flexible hoses fitted directly or indirectly between the toilet and ANY through-hull fitting that may possibly be below the waterline at ANY time, MUST be secured to the hose tails to which they are connected using stainless steel worm-drive hose clips. USE HOSE CLIPS!

### BOWL RIM BELOW WATERLINE

If the toilet is connected to ANY through-hull fittings and if the rim of the bowl falls below the waterline water may flood in, causing the craft to sink, which may result in Loss of Life.

Therefore, if the rim of the toilet is less than 20cm (8in) above the waterline when the craft is at rest, or if there is ANY possibility that the rim of the bowl may be below the waterline at ANY time, a ventilated anti-syphon loop MUST be fitted in any pipework connected to a through-hull fitting, irrespective of whether inlet or outlet. USE VENTED LOOPS!

#### SPECIAL NOTES:

THE SMALLER bore inlet pipework is more hazardous than the larger outlet pipework. Unless there is a ventilated anti-syphon loop in the inlet pipework, water will flow into the bowl whenever both the inlet seacock is open and the rim of the bowl is below the actual waterline. Although moving the Flush Control Lever (key 23) to the "Shut" position will restrict the flow, this lever CANNOT be relied upon as a safety device.

Making a loop in the hose without fitting a vent may be just as hazardous as no loop at all, because water will syphon over a loop. It is the vent that actually prevents the syphon.

## 1 LOCATION

YOUR TOILET is delivered assembled for right handed operation. If you wish, both Standard and Large Bowl models may be reassembled with the pump on the left hand side.

- Select a location that will give sufficient clearance all round and above the toilet. Ensure that there is room to operate the pump and that there is access to the drain plug at the end of the base.
- The mounting surface must be flat, rigid, strong enough to support a man's weight and should be at least 50mm (2in) wider and 50mm (2in) deeper than the base of the toilet.
- You will need sufficient clearance below the mounting surface to be able to secure the mounting bolts.
- The seat and lid should be able to swing open at least 110°, so that they will not fall forward when the craft heels or pitches. When they are swung open, they must be supported so that the hinges are not strained.

## 2 MOUNTING

YOU WILL need 4 × 8mm ( $\frac{5}{16}$ in) diameter bolts of length to suit the thickness of the mounting surface, 4 nuts, preferably self-locking, 8 large washers not more than 21mm ( $1\frac{3}{16}$ in) diameter, all in marine grade stainless steel or bronze, and a small tube of white silicone sealant. If you do not use self-locking nuts, you will need some nut-locking compound.

- Offer up the toilet in the selected position and, using the holes in the base as a guide, mark the positions for the 4 bolt holes on the mounting surface, remove the toilet and drill 4 vertical holes of 9mm diameter through the mounting surface.
- Apply a bead of white silicone sealant to the outer rim of the bottom of the base.
- Bolt down the toilet and tighten the fastenings securely. If you are not using self-locking nuts, apply nut-locking compound to the bolts.

### 3 THROUGH HULL FITTINGS

YOU WILL need a 19mm (3/4in) bore seacock for the flushing water inlet, and, if you are discharging the waste overboard, a 38mm (1 1/2in) bore seacock for the waste outlet.

- Follow the seacock manufacturers's own instructions concerning materials and methods of installation.
- Ensure that the inlet seacock is positioned where it will be below the waterline at all times when the craft is underway, and also ensure that any outlet seacock is both aft of, and higher than, the inlet seacock.

### 4 PIPEWORK – selection of correct method

YOU NEED to select the correct installation method for the inlet pipework from 2 possibilities and for the outlet pipework from 4 possibilities, according to whether the toilet is above or below the waterline, and to whether it discharges the waste overboard or into an on-board holding tank.

#### 4.1 PIPEWORK – general instructions for all possibilities

YOU WILL need spiral reinforced smooth bore flexible hose for both the 19mm (3/4in) id inlet and the 38mm (1 1/2in) id outlet pipework, and a stainless steel worm drive hose clip for every hose tail connection (4, 6 or 8).

- Secure the hose runs so that the hoses cannot move and chafe, and so that they do not exert any leverage on the hose tail fittings to which they are connected, as this may cause adjacent joints to leak
- Avoid sharp bends in the hoses that may cause them to become kinked.
- Keep all pipework lengths as short as possible, whilst complying with these instructions. Unnecessary inlet or outlet hose length just makes the toilet harder to pump.
- If it is difficult to fit the hose onto the hose tails of the toilet or seacocks, soften the hose by dipping the end of it in hot water or by heating the end gently with a hot air gun.

**CAUTION: Do not apply flame to the hose.**

**Do not apply flame or any heat to the plastic hose tails on the toilet.**

**Do not apply sealing compounds to any hose connections.**

- Secure the ends of all hoses to the hose tails with stainless steel worm drive hose clips, ensuring that all inlet connections are airtight and that all outlet connections are watertight.
- The Discharge Elbow (key 34) may be rotated 360° to suit your installation. Always slacken the 2 securing screws, adjust the discharge elbow to the required position and retighten the 2 securing screws *before* connecting the hose to it.

**CAUTION: Failure to follow this procedure may result in leaks between the elbow and the pump cylinder.**

#### 4.2 INLET PIPEWORK – 2 possibilities:

either –

##### 4.2.1 Toilet Below the Waterline

YOU WILL need a 19mm (3/4in) "Vented Loop" fitting.

- Run the inlet hose by the most direct route from the inlet seacock to the flushing pump inlet tail.
- Remove the white hose supplied with the toilet which connects the flushing pump outlet tail to the elbow (key 6).
- Using a spanner, rotate the intake seal (key 5) so that the elbow points upwards.
- Replace the white hose with a longer length of 19mm (3/4in) id hose and arrange it to form a loop whose highest point is at least 20cm (8in) above the highest possible waterline, and fit the "vented loop" at that highest point.

**CAUTION: Do not position the ventilated anti-syphon loop between the inlet seacock and the flushing pump inlet, as it will make the flushing pump difficult to prime, harder to pump, and may prevent it from working at all.**

or –

##### 4.2.2 Toilet above the Waterline

YOU MAY need a 19mm (3/4in) non-return valve

- Run the inlet hose by the most direct route from the inlet seacock to the flushing pump inlet tail.
- For maximum convenience of use, install an in-line non-return valve next to the inlet seacock which will ensure that the pump stays primed in between usages.
- The toilet flushing pump will self-prime up to 1m (3ft) above the outside water level. If there is any possibility that the toilet flushing pump inlet may be more than 1m (3ft) above the actual waterline when the craft is underway, a non-return valve must be installed next to the seacock to maintain the pump in a primed condition.

#### 4.3 OUTLET PIPEWORK – 4 possibilities

either –

##### 4.3.1 Toilet Below the Waterline, and discharging overboard

YOU WILL need a 38mm (1 1/2in) "Vented Loop" fitting

- Arrange the outlet hose to form a loop whose highest point is at least 20cm (8in) above the highest possible waterline, and fit the "vented loop" at that highest point.

or –

##### 4.3.2 Toilet Above the Waterline, and discharging overboard

YOU MAY need a 38mm (1 1/2in) "Vented Loop" fitting

- Run the outlet hose up from the discharge elbow to form a loop at least 30cm (12in) higher than the discharge elbow.
- If you fit a "vented loop" at the top of the hose loop, this will ensure that you can keep some water in the base of the toilet without risk of it being syphoned away.

or –

##### 4.3.3 Toilet waste discharging into holding tank, discharge elbow Below Top of holding tank at any time

YOU WILL need a 38mm (1 1/2in) "Vented Loop" fitting

- If the discharge elbow is less than 203mm (8in) above the top of the holding tank when the craft is at rest, or if there is ANY possibility that the discharge elbow may be below the top of the tank at ANY time, a ventilated anti-syphon loop must be fitted in the outlet pipework.
- Arrange the outlet hose to form a loop whose point is at least 203mm (8in) above the highest possible level that the top of the tank may reach, and fit the "vented loop" at that highest point.

or –

### 4.3.4 Toilet waste discharging into holding tank, discharge elbow always Above Top of holding tank

YOU MAY need a 38mm (1½in) "Vented Loop" fitting.

- Run the outlet hose up from the discharge elbow to form a loop at least 30cm (12in) higher than the discharge elbow.
- If you fit a "vented loop" at the top of the hose loop, this will ensure that you can keep some water in the base of the toilet without risk of it being syphoned away.

### 5 TESTING

REFER TO the OPERATING INSTRUCTIONS and follow the procedure for NORMAL USE.

- If the flushing pump is hard to prime, half-fill the bowl with fresh water.

### 6 SAFETY

ENSURE THAT this INSTRUCTION LEAFLET reaches the owner, skipper or operator of the craft, as it contains essential safety information.

ON COMPLETION OF INSTALLATION:  
SHUT (  ) THE FLUSH CONTROL  
CLOSE BOTH SEACOCKS

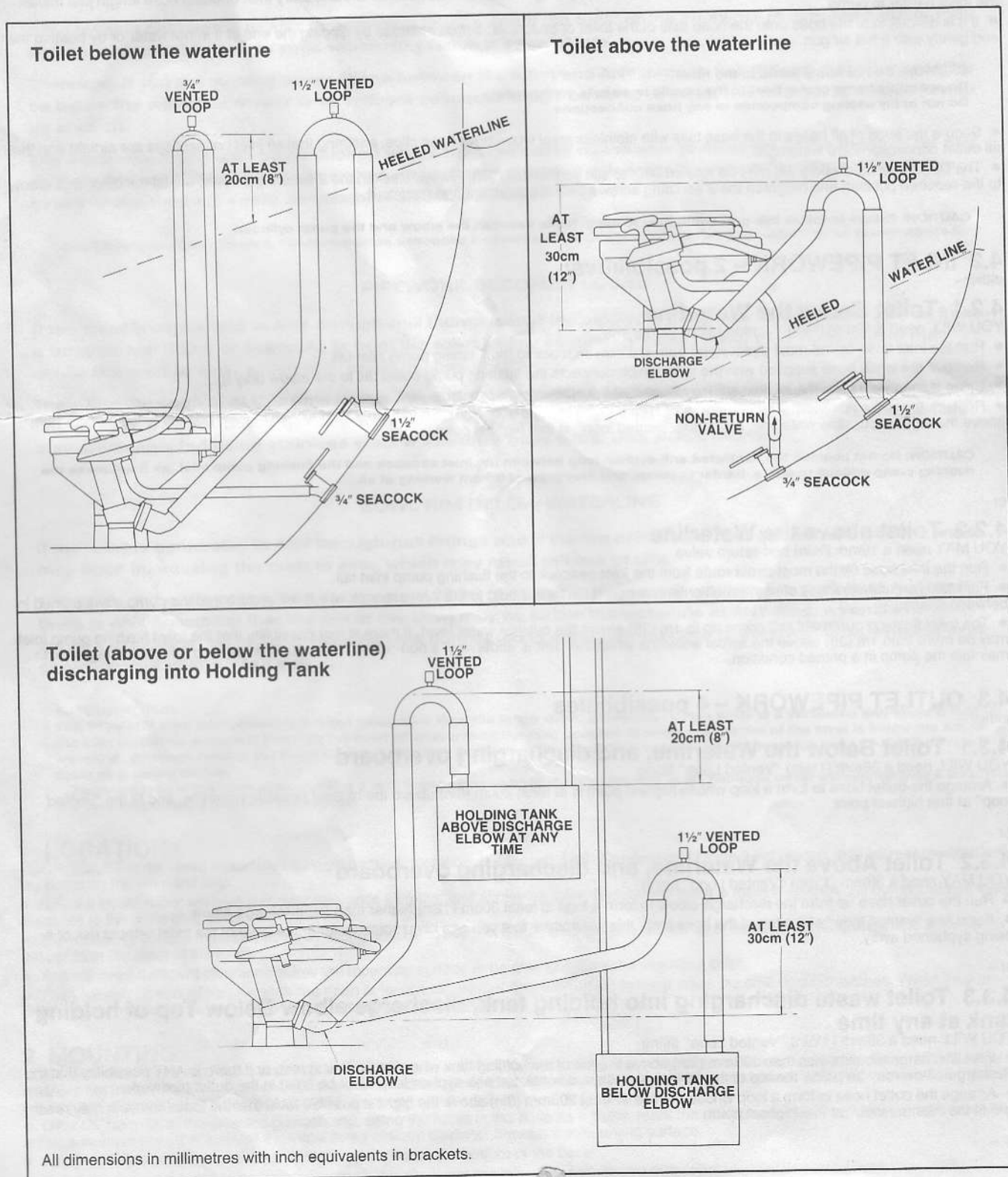

All dimensions in millimetres with inch equivalents in brackets.

# OPERATING INSTRUCTIONS

## INTRODUCTION

The toilet is one of the most used pieces of equipment on your boat. Correct operation of the toilet is essential for the safety and comfort of your crew and your craft.

### HAZARD RISK: ACCIDENTAL DAMAGE

If the toilet is connected to ANY through-hull fittings, and if the toilet or the pipework is damaged, water may flood in, causing the craft to sink, which may result in Loss of Life.

Therefore, after every usage, both seacocks (or secondary valves) MUST be shut.

Whenever your craft is unattended, even if only for a very short period of time, both seacocks (even if secondary valves are fitted) MUST be shut.

- Ensure that ALL users understand how to operate the toilet system correctly and safely – including seacocks or secondary valves.
- Take special care to instruct children, the elderly and visitors.

### SHUT SEACOCKS!

## 1 FIRST USE

AFTER PERIODS without use, the toilet may benefit from lubrication.

- Open inlet and outlet seacocks (and secondary valves if fitted).
- Half-fill the bowl with warm fresh water containing a few drops of vegetable oil or baby oil.
- Keeping the Flush Control Lever (key 23) in the Shut (  ) position, pump out the warm water.



## 2 NORMAL USE

OPEN INLET and outlet seacocks (and secondary valves if fitted).

• Before use, ensure that there is enough water in the bowl to prevent the toilet paper becoming compacted at the bottom of the bowl.

If the bowl is empty, move the Flush Control Lever (key 23) to the Open (  ) position, and pump the handle (key 17) up and down until the flushing pump is primed and water enters the bowl.

Then Shut (  ) the Flush Control.

- Operate the pump with long, smooth strokes for efficient and easy operation.
- During use, pump as necessary to keep the contents of the bowl low enough for comfort.
- Use good quality hard or soft household toilet paper, but do not use more than is necessary.
- After use, keep the Flush Control Shut (  ) and pump until the bowl is empty.
- When the bowl is empty, Open (  ) the Flush Control again, and continue to pump until all waste has either left the boat, or reached the holding tank (allow 7 complete up/down strokes per metre (yard) length of discharge pipework).
- Then Shut (  ) the Flush Control, and pump until the bowl is empty. Always leave the bowl empty to minimise odour and spillage.

### AFTER USE:

SHUT (  ) THE FLUSH CONTROL  
CLOSE BOTH SEACOCKS

**NOTE:** Do not put anything in the toilet unless you have eaten it first, except the toilet paper.

Do not put in: Sanitary Towels, Wet Strength Tissues, Cotton Wool, Cigarettes, Matches, Chewing Gum or any solid objects, Petrol, Diesel, Oil, Solvents of any kind or water more than hand hot.

## 3 CLEANING

REGULAR FLUSHING with clean sea water is one of the most effective methods of keeping the toilet clean and sweet smelling.

- To clean the bowl, use any liquid or cream ceramic cleaner.
- To clean the rest of the toilet, including the seat and lid, use a non abrasive liquid cleaner. Polish with a dry cloth only.

**CAUTION:** Do not use abrasive pads on any part of the toilet and do not use cream cleaners except for the bowl.

- To disinfect the toilet, use a liquid disinfectant diluted in accordance with the manufacturer's instructions. You may apply it to all parts of the toilet using a sponge or soft brush as necessary.

**CAUTION:** Do not use thick liquid toilet cleansers or neat bleach. They may damage the valves, gaskets and seals.

- After applying any cleaning or disinfecting agent, always flush well.

**CAUTION:** Do not allow these agents to stand in the system.

# MAINTENANCE INSTRUCTIONS

## INTRODUCTION

PAR MANUAL toilets do not normally require maintenance during the season, provided that they are winterised in the autumn and overhauled in the spring. However any toilet will benefit from:

- Thorough flushing – refer to OPERATING INSTRUCTIONS for NORMAL USE.
- Regular use – if not used regularly, lubrication is beneficial – refer to OPERATING INSTRUCTIONS for FIRST USE.

### HAZARD RISK: LEAKS

**If the toilet is connected to ANY through-hull fittings, and if the toilet or the pipework develops a minor leak, it can suddenly become a major leak that allows water to flood in, causing the craft to sink, which may result in Loss of Life.**

**Therefore, if ANY leak develops, you MUST repair it immediately. REPAIR LEAKS IMMEDIATELY!**

- Regularly check all fastenings for tightness and leaks.

## 1 SERVICING – Preparation

PAR MANUAL toilets are designed to be user serviceable and no special skills or tools are required.

- FLUSH THE toilet in accordance with the OPERATING INSTRUCTIONS for NORMAL USE, and in particular ensure that all waste has left the discharge pipework, that the bowl is empty and that BOTH SEACOCKS ARE CLOSED (even if secondary valves are fitted).
- Be ready to mop-up any water that may come out of the system.

## 2 SERVICING – Seal Replacement

IF WATER begins to leak round the piston rod (key 29) at the top of the pump, the seal assembly (key 18) is worn and should be replaced.

- You will need a PAR Service Kit part number 29044-0000.
- Raise the handle to the top of its travel and wrap one turn of tape around the piston rod *immediately below the handle*. Using pliers, grip the piston rod *only through the tape*, and unscrew the handle and remove the bumper washer (key 25).
- KEEP HOLD OF THE PISTON ROD ALL THE TIME – if you let it go, it may drop inside the pump!
- Unscrew the seal assembly and slide it off the piston. Wrap one turn of tape around the thread at the top of the piston rod to protect the new seal, slide the new seal down the piston rod and tighten it.
- Remove the tape from the threads. Replace the bumper washer and the handle, gripping the piston rod *through the tape*. Then remove the tape from the piston rod.

**CAUTION: Gripping the piston rod with a tool anywhere except the 12mm (½in) below the handle, damages the surface in a way that causes rapid seal failure.**

## 3 SERVICING – Winterisation

DRAIN THE complete system both as a protection against frost damage and to discourage the growth in the pipework of anaerobic bacteria that cause unpleasant smells.

**CAUTION: The use of anti-freeze is NOT RECOMMENDED, as it is impossible to ensure that it penetrates the complete toilet system. If, for any reason, anti-freeze is used, it MUST be glycol based.**

- Open any secondary valves
- Remove the base drain plug (key 8)
- Loosen hose clips and disconnect all the hose ends from the seacock hose tails, the toilet hose tails, and any secondary valves. Pump the handle (key 17) to drain the toilet pump, and ensure that all water is drained from the toilet system.

If you plan to overhaul the toilet in the spring, this is a good time to disassemble it and to take the components ashore to make the overhaul easier.

### HAZARD RISK: SEACOCKS OPENED BY MISTAKE

**If you leave the toilet disassembled, and if the seacocks are opened when the craft is afloat, water will flood in and may cause the craft to sink, which may result in Loss of Life.**

**Therefore you MUST attach a warning notice to the seacocks and, if possible, wire the seacocks shut. ATTACH WARNING NOTICE!**

If you are not disassembling the toilet:

- Reconnect all hose ends and secure them with their hose clips.
- Replace the base drain plug securely.
- Fasten down the seat, lid and pump handle to prevent use, and attach a warning notice.

## 4 SERVICING – Overhaul

YOU WILL need a PAR Service Kit part number 29045-0000, which contains all wearing parts – refer to PARTS LIST for details.

**CAUTION: For the safety of your craft and your crew, use only genuine PAR replacement parts.**

- Remove the pump assembly as follows:
  - Loosen hose clips, disconnect the inlet hose and the link hose (key 4) from the top of the pump.
  - Remove the 2 screws (key 31) that secure the discharge flange (key 32) to the pump cylinder (key 28).
  - Remove the 4 screws (key 31) that secure the pump cylinder to the base.
  - Lift off the pump assembly, and pick up the bottom valve gasket (key 16) and the joker valve (key 33).
- Dismantle the pump assembly as follows:
  - Remove the 6 screws (key 26) that secure the valve cover (key 27).
  - Open (☞) the Flush Control before lifting off the valve cover assembly and picking up the top valve gasket (key 21) and the valve seat (key 19).

- Remove the handle and the seal assembly by following the **SERVICING INSTRUCTIONS** for **SEAL REPLACEMENT**.
- Withdraw the piston assembly (key 29), and prise off the piston O-ring (key 30).
- Do NOT remove the bowl from the base.
- Clean and disinfect all parts – refer to **OPERATING INSTRUCTIONS** for **CLEANING**. Remove scale from the cylinder bore.
- Inspect the top and bottom valve gaskets, and the joker valve, and replace them if they are damaged, stiff or covered with scale. Automatically replace the seal assembly and the piston O-ring. Use the other parts in the kit as necessary.

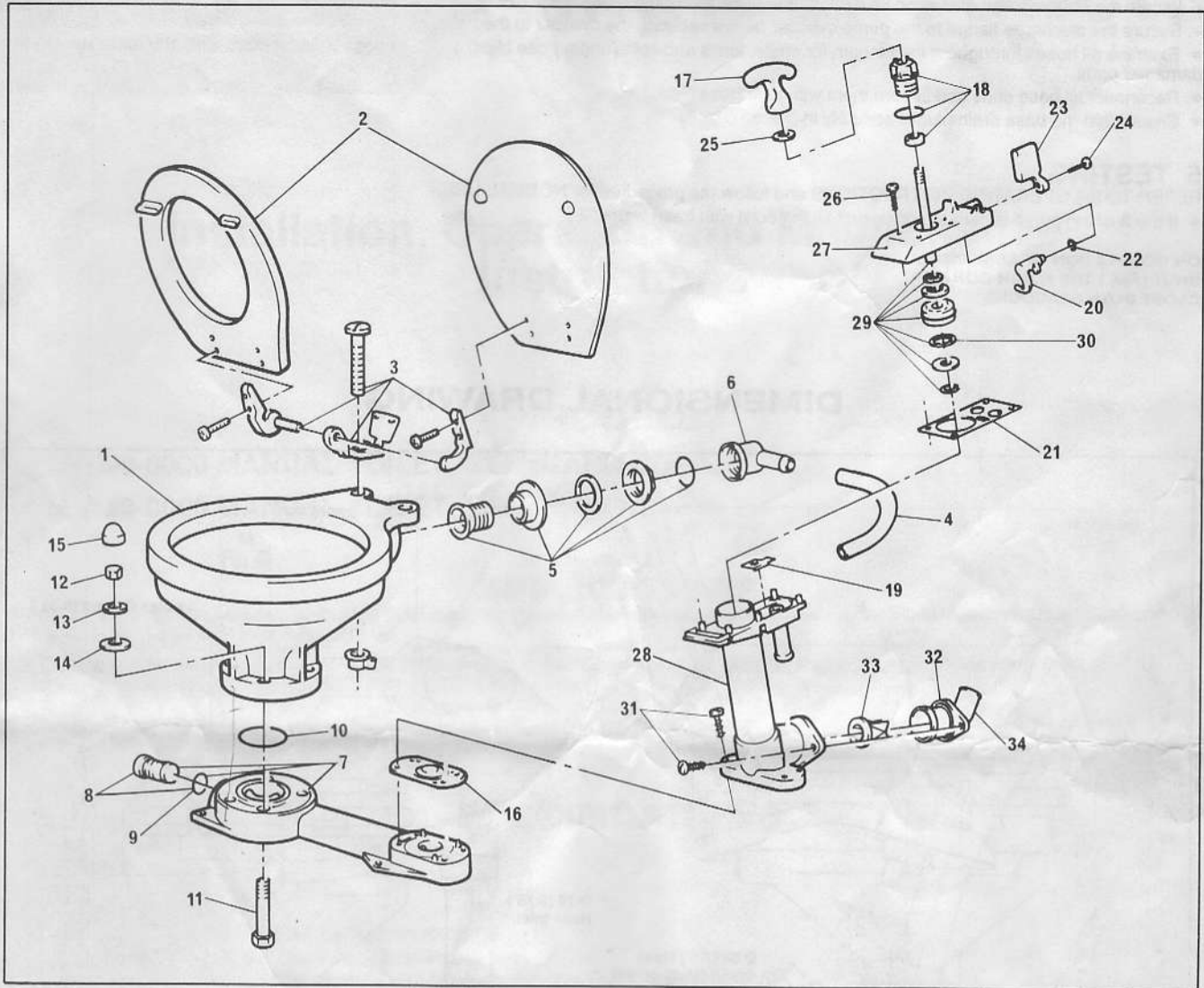

REPAIR KITS AVAILABLE		
KIT	PART NO:	DESCRIPTION
A	29045-0000	MAJOR SERVICE KIT
B	29040-1000	PUMP ASSEMBLY
C	29094-0000	VALVE COVER ASSEMBLY
D	29051-0000	PUMP CYLINDER ASSY

10	O-RING (BOWL)	1	29047-0000				
11	BOLT	4					
12	NUT	4					
13	WASHER (S.S.)	4					
14	WASHER (NYLON)	4					
15	CAP	4			2		
16	BASE VALVE GASKET	1	29043-0000	1	1		
17	HANDLE	1	29026-0000		1		
18	SEAL ASSEMBLY	1	29044-0000	1	1	1	
19	TOP VALVE SEAT	1		1	1	1	
20	CAM	1			1	1	
21	TOP VALVE GASKET	1	29042-0000	1	1		
22	O-RING (FLUSH LEVER)	1		1	1	1	
23	FLUSH CONTROL LEVER	1			1	1	
24	SCREW (FLUSH LEVER)	1		1	1	1	
25	BUFFER	1			1	1	
26	SCREW (VALVE COVER)	6		1	6	6	
27	VALVE COVER	1			1	1	
28	PUMP CYLINDER	1			1	1	
29	PISTON, ROD AND O-RING ASSY	1	29046-0000		1		
30	O-RING (PISTON)	1			1		
31	SCREW (PUMP CYLINDER)	6		1	2	2	
32	DISCHARGE FLANGE	1			1	1	
33	JOKER VALVE	1	29092-0000	1	1	1	
34	DISCHARGE ELBOW	1	29029-0000	1	1	1	

KEY	DESCRIPTION	QTY PER TOILET	PART NO:	QTY PER REPAIR KIT			
				A	B	C	D
1	BOWL STANDARD TOILET LARGE TOILET	1 1	29096-0000 29126-0000				
2	SEAT, LID & HINGE SET STANDARD TOILET LARGE TOILET	1 1	29097-0000 29127-0000				
3	HINGE SET (1 PAIR)	1	29098-0000				
4	HOSE STANDARD TOILET LARGE TOILET	1 1	29035-0000 29035-0001				
5	INTAKE SEAL +	1	29048-0000				
6	INTAKE ELBOW	1					
7	BASE, PLUG + O-RING ASSY	1	29041-1000				
8	PLUG + O-RING ASSY	1	29028-1000				
9	O-RING (PLUG)	1		1			

- Reassemble pump as follows:
  - Push on the new piston O-ring.
  - Follow the SERVICING INSTRUCTIONS for SEAL REPLACEMENT and fit the new seal assembly, the piston assembly and the handle.
  - Lubricate pump cylinder bore with petroleum jelly (Vaseline).
  - Locate the valve seat on the top of the cylinder, locate the top valve gasket on its pegs on the top of the cylinder, and Open (↔) the Flush Control before refitting the valve cover.
- Refit pump assembly on the toilet as follows:
  - Locate the bottom valve gasket on its pegs on the base, and locate the joker valve in the discharge elbow.
  - Secure the discharge flange to the pump cylinder *before* securing the cylinder to the base.
- Examine all hoses throughout their length for chafe, kinks and splits under hose clips, check all hose clips for corrosion, and replace worn or damaged parts.
- Reconnect all hose ends and secure them with their hose clips.
- Ensure that the base drain plug is securely in place.

## 5 TESTING

REFER TO the OPERATING INSTRUCTIONS and follow the procedure for NORMAL USE.

- If the flushing pump is hard to prime, half-fill the bowl with fresh water.

**ON COMPLETION OF SERVICING:**  
**SHUT (→) THE FLUSH CONTROL**  
**CLOSE BOTH SEACOCKS**

## DIMENSIONAL DRAWING

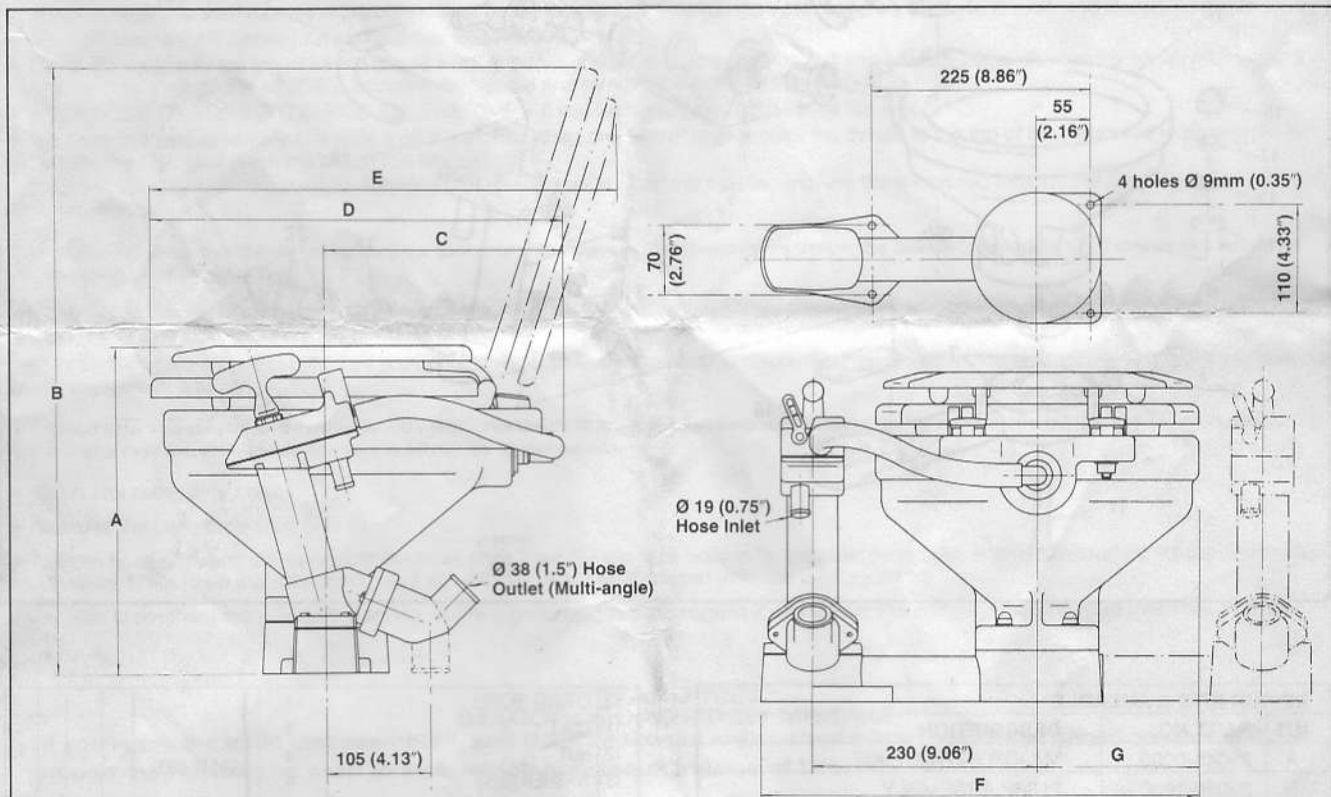

All dimensions in millimetres with inch equivalents in brackets.

		A	B	C	D	E	F	G	
29090-0000	MANUAL TOILET STANDARD BOWL	335 (13.19)	615 (24.21)	247 (9.72)	425 (16.73)	485 (19.09)	450 (17.72)	165 (6.50)	mm (ins)
29120-0000	MANUAL TOILET LARGE BOWL	345 (13.58)	700 (27.56)	280 (11.02)	490 (19.29)	580 (22.83)	465 (18.31)	180 (7.09)	mm (ins)



### ITT JABSCO

A Division of ITT Industries Ltd  
 BINGLEY ROAD, HODDESDON  
 HERTFORDSHIRE, EN11 0BU, ENGLAND  
 TEL: HODDESDON (0992) 467191 INT. TEL: +44-992-467191  
 TELEX: 263251 FACSIMILE: 0992 467132  
 Designers, Manufacturers and Suppliers of JABSCO · PUREFLO · PAR · RAY-LINE · BRYDON

