

Jabsco 28340 : 28380 SERIES

EXPLODED VIEW

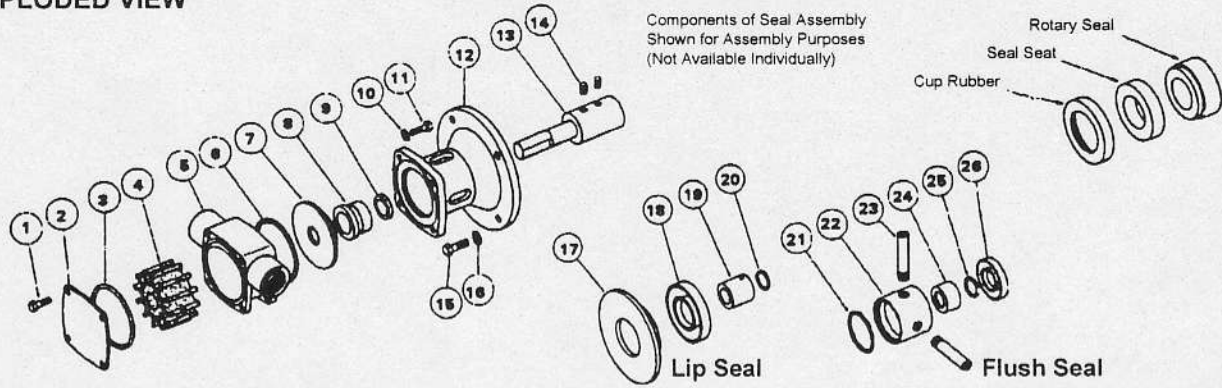

PARTS LIST			STANDARD PRESSURE IMPELLER			HIGH PRESSURE IMPELLER		
			Neoprene Elast: 28340-2101	Nitrile Elast: 28340-2103	Viton Elast: 28340-2104	Neoprene Elast: 28380-2121	Nitrile Elast: 28380-2123	Viton Elast: 28380-2124
Key	Description	Qty						
1	Screw*	4	X3001-176F	X3001-176F	X3001-176F	X3001-176F	X3001-176F	X3001-176F
2	Endcover	1	28305-0010	28305-0010	28305-0010	28305-0010	28305-0010	28305-0010
3	"O" Ring*	1	X4020-269A	X4020-269A	X4020-269B	X4020-269A	X4020-269A	X4020-269B
4	Impeller*	1	14282-0001B	14282-0003B	14282-0004B	8840-0021B	8840-0023B	8840-0024B
5	Body	1	28334-2000	28334-2000	28334-2000	28334-2000	28334-2000	28334-2000
6	"O" Ring*	1	X4020-269A	X4020-269A	X4020-269B	X4020-269A	X4020-269A	X4020-269B
7	Wearplate(1)	1	28336-0000	28336-0000	28336-0000	28336-0000	28336-0000	28336-0000
8	Seal Assembly(1)*	1	28331-0103B	28331-0103B	28331-0104B	28331-0103B	28331-0103B	28331-0104B
9	Seal Spacer (1,2,3)	1	28319-0000	28319-0000	28319-0000	28319-0000	28319-0000	28319-0000
10	Washer	4	X3080-091F	X3080-091F	X3080-091F	X3080-091F	X3080-091F	X3080-091F
11	Screw	4	X3001-180F	X3001-180F	X3001-180F	X3001-180F	X3001-180F	X3001-180F
12	Adaptor	1	28323-0000	28323-0000	28323-0000	28323-0003	28323-0003	28323-0003
13	Shaft Extension	1	28327-0001	28327-0001	28327-0001	Requires Integral Motor Shaft. See Drawing For Details		
14	Set Screw	2	X3009-176A	X3009-176A	X3009-176A	X3001-180F	X3001-180F	X3001-180F
15	Screw	4	X3001-180F	X3001-180F	X3001-180F	X3001-180F	X3001-180F	X3001-180F
16	Washer	4	X3080-091F	X3080-091F	X3080-091F	X3080-091F	X3080-091F	X3080-091F
Service Kit Contains*			SK377-0101	SK377-0103	SK377-0104	SK377-0121	SK377-0123	SK377-0124
Other Seal Options								
Model No. With H/F Seal	28340-2201	28340-2203	28340-2204	28340-2221	28340-2223	28340-2224		
Model No. With Lip Seal	28340-2401	28340-2403	Not Available	28340-2421	28340-2423	Not Available		
Model No. With H/F Seal Flushed	28340-2701	28340-2703	28340-2704	28340-2721	28340-2723	28340-2724		
Model No. With Standard Seal Flushed	28340-2901	28340-2903	28340-2904	28340-2921	28340-2923	28340-2924		
Parts For Appropriate Seal Conversion								
8	H/F Seal Assembly	1	28331-0203B	28331-0203B	28331-0204B	28331-0203B	28331-0203B	28331-0204B
Lip Seal Kit No. & Contains	28331-0403B	28331-0403B	Not Available	Not Available	Not Available	Not Available	Not Available	Not Available
17	Wearplate	1	28336-0000	28336-0000	Not Available	Not Available	Not Available	Not Available
18	Seal	1	SP2701-0914	SP2701-0914	Not Available	Not Available	Not Available	Not Available
19	Seal Spacer	1	28365-0011	28365-0011	Not Available	Not Available	Not Available	Not Available
20	"O" Ring	1	X4020-217A	X4020-217A	Not Available	Not Available	Not Available	Not Available
Flush Seal Kit No. & Contains	28332-0000B	28332-0000B	28332-0000B	Not Available	Not Available	Not Available		
21	"O" Ring	1	X4020-244A	X4020-244A	X4020-244A	Not Available	Not Available	Not Available
22	Seal Housing	1	28312-0000B	28312-0000B	28312-0000B	Not Available	Not Available	Not Available
23	Tube	2	21844	21844	21844	Not Available	Not Available	Not Available
24	Seal Spacer(2)	1	28319-0001	28319-0001	28319-0001	Not Available	Not Available	Not Available
25	"O" Ring(2)	1	X4020-217A	X4020-217A	X4020-217A	Not Available	Not Available	Not Available
26	Seal	1	SP2701-0914	SP2701-0914	SP2701-0914	Not Available	Not Available	Not Available
(1) Key 7, 8 & 9 Not Required For Lip Seal Models. (2) Key 9, 24 & 25 Not Required For one piece Shaft								
(3) Key 9 Required For High Pressure Impeller Models								

SERVICE INSTRUCTIONS

Dis-Assembly

- Remove screws (1), endcover and "O" rings (3). Remove screws (11) and slide off body complete with body. Push out impeller and "O" ring (6) from body.
- Remove wearplate (7) and prise out seal seat and cup rubber.
- Gently lever the spacer (9), (if fitted) and rotary seal off the shaft. Removal of the following parts is not necessary for normal servicing. However, if required proceed as follows:-
- Remove screws (15) and washers (16) and slide off adaptor (12).
- Loosen set screws (14) then applying heat and leverage slide off shaft extension. Do not heat damage motor seal and bearing. Do not tamper with motor.

Pumps With Lip Seal:- Push out lip seal (18) from wearplate (17) and loosen set screws to remove spacer (19) and prise out "O" ring (20) from spacer.

Pumps With Flush Seal:- After pulling out rotary seal, unscrew tubes (23) and pull out seal housing (22). If fitted:- Remove seal spacer and prise out "O" ring (25). Remove "O" ring (21) and lip seal (26) from seal housing.

Assembly

- To assemble shaft extension (Not applicable to H.P pumps):- Support motor shaft (from end). Align set screws (14) with the shaft keyway and press on the shoulder of the shaft extension. Tighten set screws (14).
- Slide seal spacer (9) (if fitted), on shaft then smear shaft with oil and push rotary seal gently until it touches the spacer or shaft shoulder.
- Fit adaptor (12) to motor face with screws (15) and washers (16).
- Fit cup rubber and seal seat into wearplate and slide over shaft and into adaptor.
- Fit impeller into lubricated body with a twisting motion in the same direction as motor. Fit "O" ring (6) into body and slide into position over shaft.
- Align wearplate and body with adaptor and secure with screws (11) and washers (10). Do not overlighten, a gap between adaptor and body is normal. These screws and endcover screws should be tightened to a torque of 3.4 Nm.
- Fit "O" ring (3) into body and place endcover over body and secure with screws (1).

Pumps With Lip Seal:- Fit "O" ring (20) into seal spacer (19) and smear spacer and shaft with lubricating oil. Slide spacer over shaft and secure with set screws to dimension shown. Press lip seal (18) into wearplate (17) and slide into position over shaft, then follow in from step 5 above.

Pumps With Flush Seal:- (shafts with seal spacer (24)). Fit "O" ring (25) under seal spacer and smear both spacer and shaft with oil and slide spacer up to shaft shoulder. Press lip seal (26) into seal housing (22) and slide into position. Fit tubes (23) sealing with PTFE tape. Rotary seal and "O" ring (21) can now be fitted. Then follow step 5 above.

Inspect all parts of wear or damage and replace if necessary.

INSTALLATION DRAWING

