

Other JABSCO models are also available in bronze, plastic, cast iron and unpolished stainless steel. JABSCO Pureflo pumps are also available for sanitary applications.

DESIGN FEATURES

Body:	Bronze
Impeller:	Jabsco Neoprene Compound
Shaft:	Bronze
Shaft Seal:	Lip Type
Bearings:	Shielded Ball Bearings
Ports:	3/8" NPT
Weight:	2 3/4 lbs. (approx.) (1,25 kgs)

VARIATIONS AVAILABLE

MODEL VARIATIONS INCORPORATED

2620-0003	Nitrile Impeller
2620-0051	Half Thickness Cam, Neoprene Impeller

APPLICATIONS & OPERATING INSTRUCTIONS

MARINE: Engine cooling, Pumping bilges, Washdowns, Circulating water in bait tanks, Utility dock side pump.

INDUSTRIAL: Circulating and transferring, Velocity-mixing, Pumping machine tool coolants, Return spill, Sump drainage, Chemicals, Pharmaceuticals, Soap, Liquors, Ink, Dyes, Alcohol, Various acids, Tanning liquors, Glycerine, Brine, etc.

1. **INSTALLATION** – Pump may be mounted in any position. Intake and discharge ports are determined by the direction of shaft rotation (refer to Dimensional Drawing). Before installing, turn the pump shaft in the direction of the operating rotation.

2. **DRIVE** – Belt or Direct with flexible coupling. If pulley or coupling are a press fit on shaft, support shaft when installing driver to prevent shaft movement.

Belt Drive – Overtight belt load will reduce pump bearing life.

Direct Drive – Clearance should be left between drive shaft and pump shaft when installing coupling. Always mount and align pump and drive shaft before tightening the coupling set screw.

3. **SPEEDS** – 100 RPM to the maximum shown in the performance table. Consult the factory for operation at speeds above those shown. For longer pump life, operate at lowest possible speeds.

4. **SELF-PRIMING** – Primes at low or high speeds. For vertical dry suction lift of 10 feet (3,0m), a minimum of 800 RPM is required.

Pump will produce suction lift up to 22 feet (6.7m) when wetted. **BE SURE SUCTION LINES ARE AIR TIGHT OR PUMP WILL NOT SELF-PRIME.**

5. **RUNNING DRY** – Unit depends on liquid pumped for lubrication. **DO NOT RUN DRY** for more than 30 seconds. Lack of liquid will burn the impeller.

6. **CAUTION** – Do not pump light fraction petroleum derivatives, solvents, thinners, highly concentrated or organic acids. Consult Jabsco "Chemical Resistant Table" for proper body materials and impeller compounds. If corrosive fluids are handled, pump life will be prolonged, if flushed with water after each use or after each work day.

Continued

OPERATING INSTRUCTIONS (Cont'd.)

7. **PRESSURES** — Consult Head Capacity Table for recommended maximum for continuous operation. If pressures exceed those shown, consult the factory.

8. **TEMPERATURES**
 Neoprene: 45° to 180°F.
 Nitrile: 50° to 180°F.

9. **FREEZING WEATHER** — Drain unit by loosening end cover. The following anti-freeze compounds can be used without any adverse effects to the impeller: Atlas "Perma-guard", Du Pont "Zerex" and "Telar", Dow Chemical "Dow-guard" and Olin Mathison "Pyro Permanent".
DO NOT USE PETROLEUM BASED ANTI-FREEZE COMPOUNDS OR RUST INHIBITORS.

10. **GASKET** — Use a standard pump part. Thicker gasket will reduce priming ability. A thinner gasket will cause the impeller to bind. Standard gasket is .010 thick.

11. **SPARE PARTS** — To avoid costly shut downs, keep a JABSCO Service Kit on hand.

HEAD CAPACITY TABLES

MODEL 2620-0001

TOTAL HEAD		500 RPM		1160 RPM		1750 RPM		2100 RPM		2450 RPM		3000 RPM		3600 RPM	
Head in Feet (Meters)	Lbs. per Sq. Inch (kg/sq cm)	GPM (Liter/Min)	HP	GPM (Liter/Min)	HP	GPM (Liter/Min)	HP	GPM (Liter/Min)	HP	GPM (Liter/Min)	HP	GPM (Liter/Min)	HP	GPM (Liter/Min)	HP
10 (3,0)	4.3 (3)	1.5 (5,7)	1/12	4.0 (15,1)	1/6	6.0 (22,7)	1/4	7.3 (27,6)	1/4	8.4 (31,8)	1/3	10.3 (39,0)	1/3	11.9 (45,0)	1/3
20 (6,1)	8.7 (6)	1.2 (4,5)	1/12	3.3 (12,5)	1/6	5.2 (19,7)	1/4	6.5 (24,6)	1/4	7.5 (28,4)	1/3	9.4 (35,6)	1/3	10.8 (40,9)	1/3
30 (9,1)	13.0 (9)	.5 (1,9)	1/12	2.4 (9,1)	1/6	4.2 (15,9)	1/4	5.5 (20,8)	1/4	6.5 (24,6)	1/3	8.4 (31,8)	1/3	9.6 (36,3)	1/2
40 (12,2)	17.3 (1,2)			1.4 (5,3)	1/6	3.0 (11,4)	1/4	4.3 (16,3)	1/4	5.3 (20,1)	1/3	7.1 (26,9)	1/3	8.2 (31,0)	1/2
50 (15,2)	21.6 (1,5)											5.6 (21,2)	1/3	6.7 (25,4)	1/2

Capacities reduced by approximately 10% using Nitrile impeller at higher speeds and higher pressures.

MODEL 2620-0051

TOTAL HEAD		500 RPM		1160 RPM		1750 RPM		2100 RPM		2450 RPM		3000 RPM		3600 RPM	
Head in Feet (Meters)	Lbs. per Sq. Inch (kg/sq cm)	GPM (Liter/Min)	HP	GPM (Liter/Min)	HP	GPM (Liter/Min)	HP	GPM (Liter/Min)	HP	GPM (Liter/Min)	HP	GPM (Liter/Min)	HP	GPM (Liter/Min)	HP
10 (3,0)	4.3 (3)	.8 (3,0)	1/12	2.0 (7,6)	1/6	3.3 (12,5)	1/4	4.1 (15,5)	1/4	5.1 (19,3)	1/4	6.3 (23,8)	1/3	7.9 (29,9)	1/2
20 (6,1)	8.7 (6)	.7 (2,6)	1/12	1.7 (6,4)	1/6	2.8 (10,6)	1/4	3.7 (14,0)	1/4	4.3 (16,3)	1/4	5.6 (21,2)	1/3	7.0 (26,5)	1/2
30 (9,1)	13.0 (9)					2.0 (7,6)	1/4	2.7 (10,2)	1/4	3.3 (12,5)	1/4	4.6 (17,4)	1/3	5.9 (22,3)	1/2
40 (12,2)	17.3 (1,2)													4.7 (17,8)	1/2

Capacities reduced by approximately 10% using Nitrile impeller at higher speeds and higher pressures.

NOTE: Progressively longer life may be expected as operating pressures and speeds are reduced. Factory Application Engineering assistance suggested for operation in light shaded area and recommended for heavy shaded area. Capacitor type motor recommended. Table shows approximate Head-Flow for new pump in U.S. gallons per minute and liters per minute.

EXPLODED VIEW

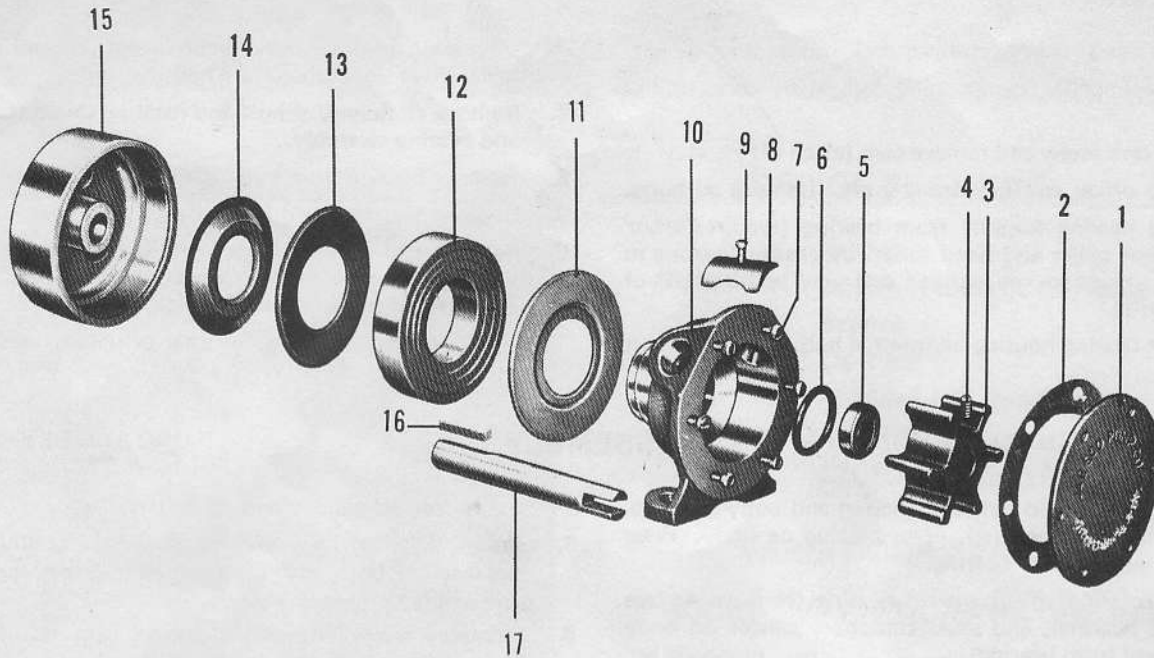

Model 2620-0003 & Variations

KEY	DESCRIPTION	PART NUMBER	QTY. REQ.
1	End Cover	11830-0000	1
2	*Gasket Standard Half-Cam Version	2995-0000 2442-0000	1
3	*Impeller Neoprene Nitrile	673-0001 673-0003	1
4	Screw (Impeller)	91010-0060	1
5	*Seal (Shaft)	92700-0050	1
6	**"O" Ring	92000-0430	1
7	Screw (End Cover)	91002-0020	6
8	Cam Standard Half-Cam Version	2907-0000 2441-0000	1
9	Screw (Cam) Standard Half-Cam Version	91002-0090 91002-0010	1
10	Body	2438-0000	1
11	Bearing Shield	3078-0000	1
12	Ball Bearing	92600-0330	1
13	Rotating Shield	1161-0000	1
14	Stationary Slinger	1554-0000	1
15	Bearing Housing	345-0000	1
16	Key (Shaft Drive)	11847-0000	1
17	Shaft	688-0240	1
Not Shown	Service Kit, Neoprene Service Kit, Nitrile	90020-0001 90020-0003	

*Parts supplied in Service Kit

SERVICE INSTRUCTIONS

TO CHANGE IMPELLER:
FOLLOW STEPS 1 & 2.

1. Remove end cover screws, end cover and gasket.
2. Remove impeller by grasping hub with water pump pliers.
3. Loosen cam screw and remove cam (clean off Permatex).
4. Remove driver and key from shaft. Remove all burrs.
5. Remove bearing housing from bearing (requires arbor press, gear puller and hand torch) by heating housing to 325°F. Housing will expand and may be lifted off of the bearing.
6. Support bearing housing on internal hub. Press shaft out

DISASSEMBLY

TO CHANGE SEAL:
FOLLOW STEPS 1, 2, 5 & 10.

7. of bearing housing. Press on drive end. Do not press impeller drive slot through the housing.
7. Remove stationary slinger and rotating shield from body and bearing assembly.
8. Remove bearing from body with gear puller.
9. Remove bearing shield from body.
10. Remove seal assembly from seal bore by pressing from bearing end toward impeller bore. Remove "O" ring from groove in seal-bore with pick.

Note: Inspect all parts for wear or damage and replace where necessary.

TO INSTALL NEW IMPELLER:
FOLLOW STEPS 7 & 8.

1. With bearing shield between bearing and body (rim projection towards bearing), press bearing on body. Press against inner race of bearing.
2. Install rotating shield against bearing (concave surface towards bearing), and press stationary slinger on body (cup away from bearing).
3. Press shaft into bearing housing. Support housing and press keyway end through shaft hole, until it protrudes 1 9/32" from housing face.
4. Heat bearing housing and shaft assembly to 325°F. Center rotating shield on bearing and quickly install over bearing. Note: Housing will shrink immediately on contact with bearing, therefore, it must be positioned

ASSEMBLY

TO INSTALL NEW SEAL:
FOLLOW STEPS 5, 7 & 8.

- and bottomed quickly and accurately.
5. Install "O" ring in groove in seal bore and lubricated seal into seal bore, with lip toward impeller bore. Make sure seal is bottomed firmly.
6. Permatex screw threads and top of cam and install in body. Secure with cam screw.
7. Lubricate impeller bore with light coat of water pump grease (Marfak 2HD or equal), and start impeller into bore with a rotary motion, until impeller screw engages slot in shaft, then push into bore.
8. Install gasket and end cover. Secure with end cover screws.

DIMENSIONAL DRAWING

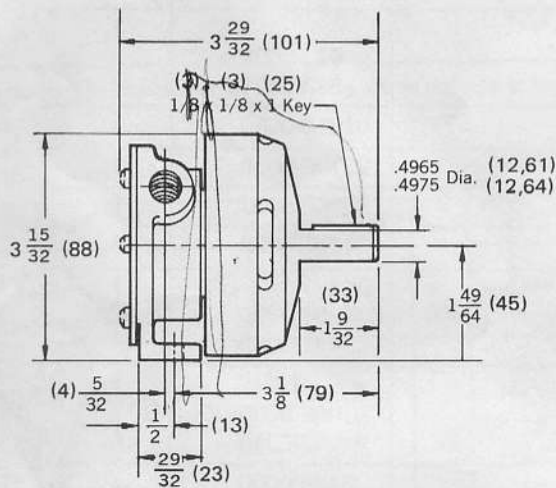

(Millimeter Equivalents)

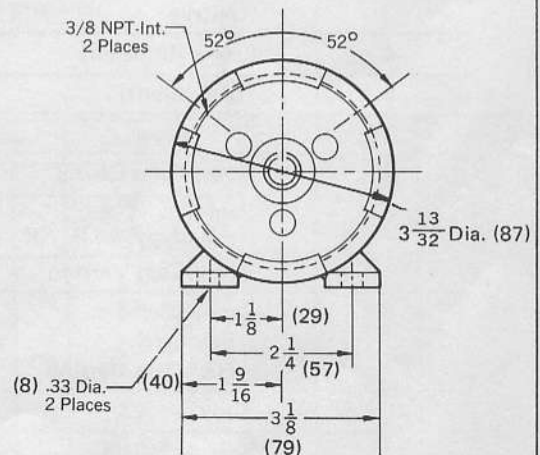
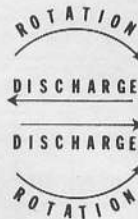

JABSCO PRODUCTS **ITT**

A Unit of International Telephone and Telegraph Corporation • 1485 Dale Way, Costa Mesa, California 92626