

EXPLODED VIEW

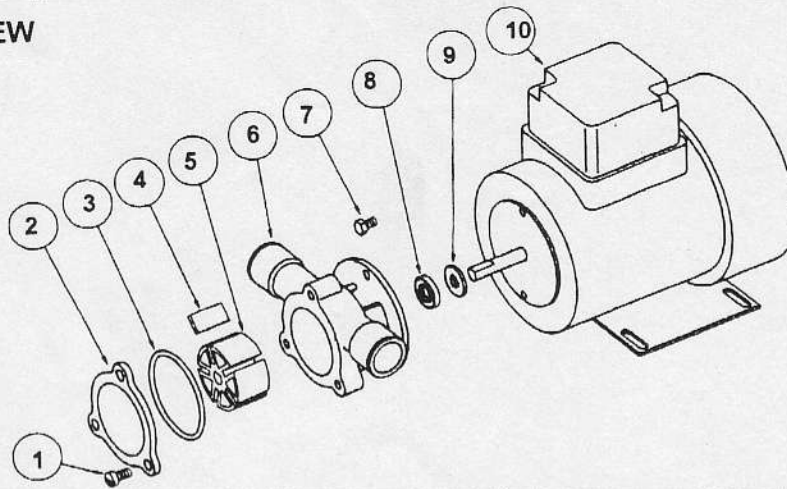

Key	Description	Qty	Part No.
1	Endcover Screw *	3	SP1004-09
2	Endcover	1	45717-0000
3	"O" Ring *	1	SP2000-1258
4	Vanes *	5	45716-0000
5	Rotor *	1	45714-0000
6	Body	1	18648-0000
7	Motor Screw	2	SP8019-02
8	Lip Seal *	1	SP2701-52
9	Slinger	1	6342
10	Motor	1	SP8012-0138

Service Kit SK383-0000 contains parts marked *

Head Kit 23731-0200 contains all parts except key 10

Motor Spares for SP 8012-0138

Part No.	Description
X 5501-019B	Capacitor
X 5501-020B	Motor Cowl

Motor is not user servicable.No other spares are available. Motor has a auto reset thermal trip.If motor stops allow to cool before restarting.

Dis - Assembly

1. Remove endcover screws, endcover, and "O"ring.
2. Withdraw rotor and vanes.
3. Remove two slotted hex screws.Tap body lightly between ports and remove.
4. Press seal from the rotor side of the body out of the seal bore.

Assembly

1. Press seal from the motor side of the body into the seal bore with lip positioned downwards.
2. Lubricate motor shaft and install body onto motor
3. Align flat in rotor with flat on motor shaft and push on.Install vanes as shown below.
4. Install "O" ring,endcover,and endcover screws.

INSTALLATION DRAWING

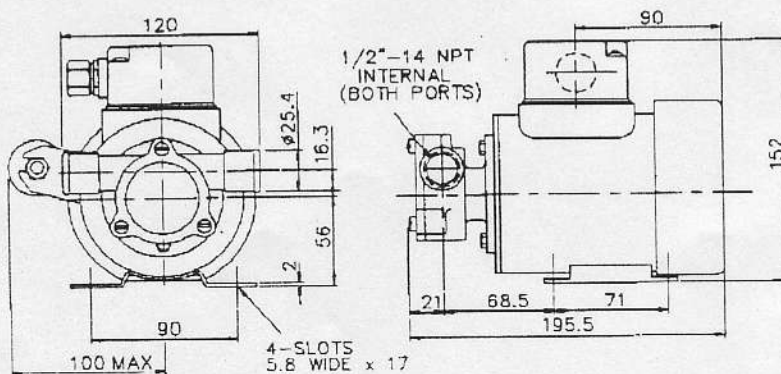

Assemble Vanes As Shown
With Radiussed Edge Leading
For Anti - Clockwise Rotation

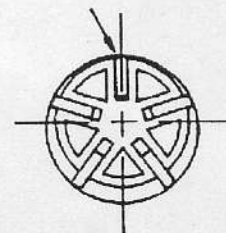

Viewed From Front