

# Jabsco 23630 : 23631 SERIES

## EXPLODED VIEW

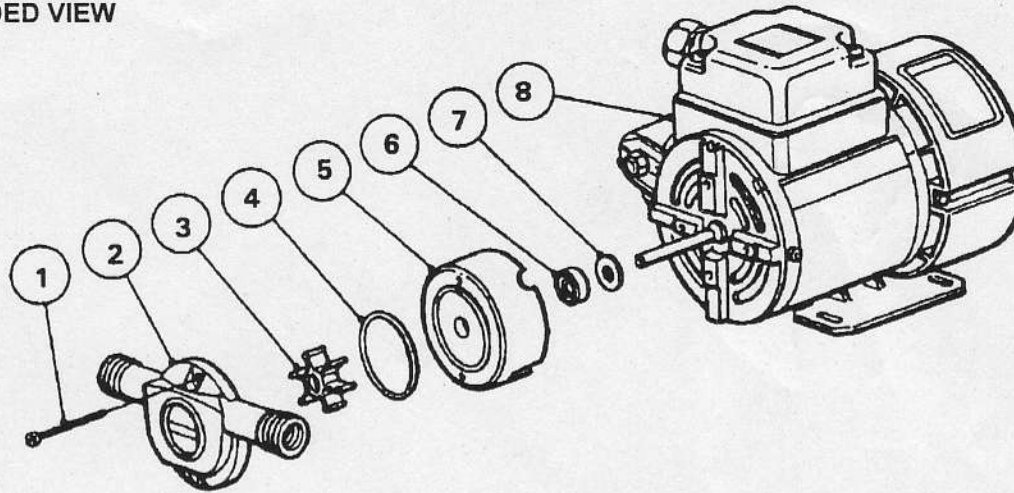

PARTS LIST			STANDARD PRESSURE IMPELLER	
			Neoprene Elast: 23630-9401	Nitrile Elast: 23630-9403
Key	Description	Qty		
1	Screw	2	91023-0050	91023-0050
2	Body	1	12375-0000	12375-0000
3	Impeller*	1	23740-0001B	23740-0003B
4	"O" Ring*	1	SP2000-0750	SP2000-0750
5	Seal Housing	1	12314-0000	12314-0000
6	Seal*	1	SP2701-52	SP2701-52
7	Slinger	1	6342	6342
8	Motor	1	SP8012-0138	SP8012-0138
9	Gland (Not Shown)	1	SP8022-44	SP8022-44
Service Kit Comprises*			SK398-0001	SK398-0003
Head Kit Model No. Parts As Above Except Key 8&9			23631-9401	23631-9403

Note: Key 8 (Motor) is unsuitable for High Pressure Impeller

Head Kit Model No. With High Pressure Impeller	23631-9421	-
High Pressure Impeller	14787-0021B	-
Standard Pressure Impeller (Standard Size)	14792-0001	14792-0003

## SERVICE INSTRUCTIONS

### Dis-Assembly

1. Remove body screws, body and seal housing.
2. Withdraw impeller, care must be taken not to damage body bore.
3. Remove "O" ring from seal housing.
4. Press seal out of cavity from impeller side.
5. Do not remove slinger.
6. Do not tamper with or disassemble motor.

### Assembly

1. Lubricate seal with petroleum jelly and install seal into seal cavity with spring facing towards the impeller.
2. Lubricate motor shaft with grease and install seal housing onto motor and replace "O" ring in the seal housing.
3. Install impeller into lubricated body with a twisting motion in the same rotation as the motor.
4. Align "flat" of shaft and impeller insert and push body towards the seal housing. Secure with screws onto motor face.

Inspect all parts for wear or damage and replace if necessary.

## INSTALLATION DRAWING 23630 Series

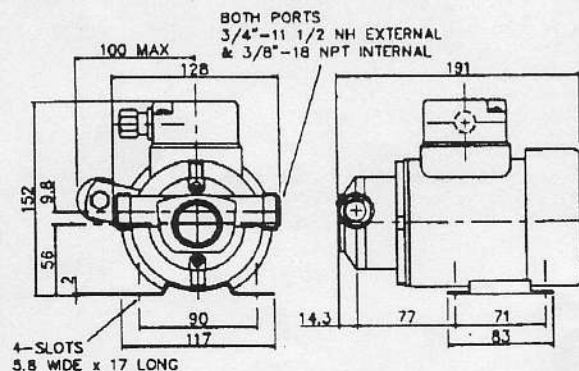

## HEAD KIT 23631 Series

