

# Jabscos 22340 : 22341 SERIES

## EXPLODED VIEW

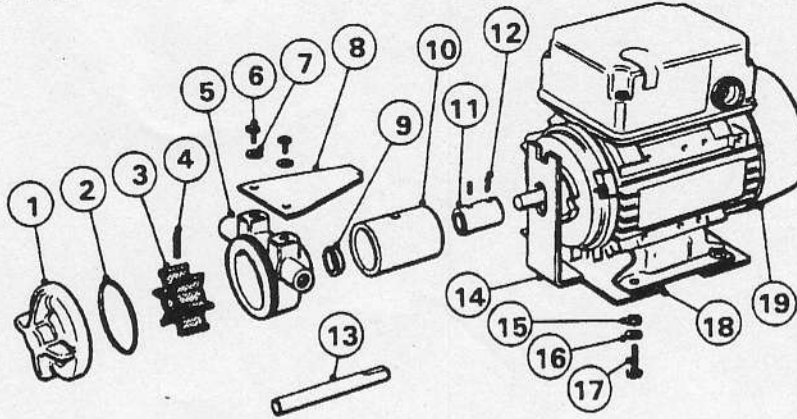

Model Now Obsolete - Data For Spare Parts Only

PARTS LIST			MEDIUM PRESSURE IMPELLER				
Key	Description	Qty	Neoprene Elast: 22341-8411	Nitrile Elast: 22341-8413	Viton Elast: 22341-8411	Hast "B" Shaft 22341-02-8411	Titanium 22341-15-8411
1	Endcover with Bearing	1	8187	8187	8187	8187	8187
2	"O" Ring*	1	SP2000-59	SP2000-59	SP2000-79	SP2000-59	SP2000-59
3	Impeller*	1	3398-0011B	3398-0013B	3398-0014B	3398-0011B	3398-0011B
4	Impeller Screw*	1	SP1029-07	SP1029-07	SP1029-07	SP2850-03	3452-15
5	Body with Bearing	1	8188	8188	8188	8188	8188
6	Screws	2	SP1095-32	SP1095-32	SP1095-32	SP1095-32	SP1095-32
7	Lockwashers	2	SP1602-06	SP1602-06	SP1602-06	SP1602-06	SP1602-06
8	Torque Arm	1	22345	22345	22345	22345	22345
9	Seal*	1	SP3000-08	SP3000-08	SP3000-08	SP3000-08	SP3000-08
10	Coupling Guard	1	22349	22349	22349	22349	22349
11	Coupling	1	22348	22348	22348	22348	22348
12	Set Screws	2	X3009-145A	X3009-145A	X3009-145A	X3009-145A	X3009-145A
13	Shaft	1	1983-01	1983-01	1983-01	1983-02	1983-15
14	Torque Arm Stop Plate	1	22346	22346	22346	22346	22346
15	Nut	4	X3070-091C	X3070-091C	X3070-091C	X3070-091C	X3070-091C
16	Washer	4	X3081-091F	X3081-091F	X3081-091F	X3081-091F	X3081-091F
17	Bolt	4	X3004-182C	X3004-182C	X3004-182C	X3004-182C	X3004-182C
18	Mounting Plate	1	22347	22347	22347	22347	22347
19	Motor	1	SP8012-0137	SP8012-0137	SP8012-0137	SP8012-0137	SP8012-0137
20	Endcover/Body Bearing (not shown)	1	3625-1150	3625-1150	3625-1150	3625-1150	3625-1150
Service Kit Comprises*			SK26-101	SK26-101-37	SK26-101-59	-	-
Model 22340 As Shown Above Except Key 19			22340-8411	22340-8413	22340-8414	22340-8411	22340-15-8411
Note: Pumps With Hast "B" & Titanium Shafts With Nitrile & Viton Elastomers Are Available From Jabscos Distributor. Elastomer Part Numbers Are As Above.							

## SERVICE INSTRUCTIONS

### Dis-Assembly

1. Remove torque arm.
2. Rotate coupling guard so that the hole lines up grub screw (pump shaft to coupling). Loosen grub screw with allen key and withdraw complete pump.

Note: For pump assembly follow instructions for 3010 Series.

Do not Tamper with Motor.

### Assembly

Note: For pump dis-assembly follow instructions for 3010 Series then as follows:-

1. If coupling has been removed from motor shaft, refit and secure with set screw.
  2. Slide coupling guard over coupling, line up hole in guard with the coupling front grub screw.
- Note: Make sure that chamfered end of guard is facing away from motor.
3. Position shaft of assembled pump so that it abuts motor shaft then tighten grub screw with allen key.
  4. Refit torque arm making sure that the tongue fits into the slot of the torque arm stop plate.

Inspect all parts for wear or damage and replace if necessary

## INSTALLATION DRAWING

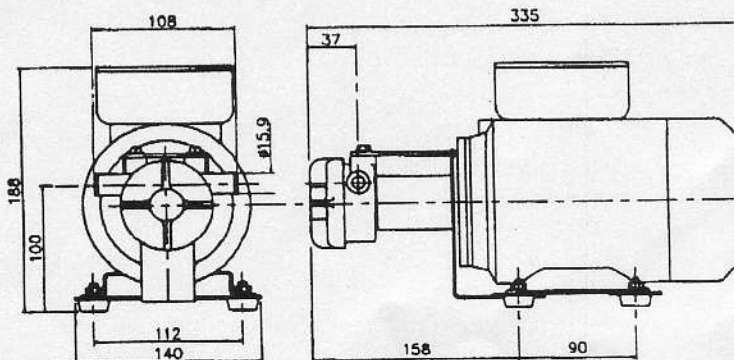

SUITABLE FOR UP TO 0.8 BAR DIFFERENTIAL PRESSURE