

Jabsco 21860: 22218 SERIES

EXPLODED VIEW

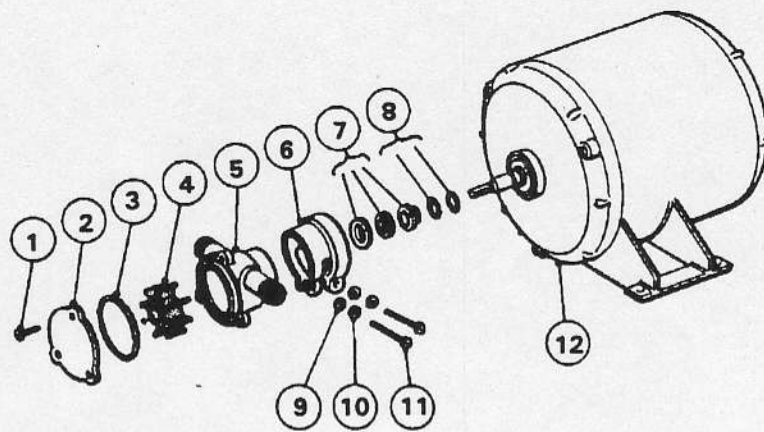

Components of Seal Assembly
Shown for Assembly Purposes
(Not Available Individually)

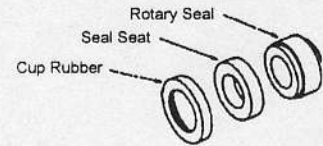

PARTS LIST			MEDIUM PRESSURE IMPELLER				HIGH TEMPERATURE IMPELLER
			Neoprene Elast:	Nitrile Elast:	3A Neoprene Elast:	3A Neoprene Elast:	3A Neoprene Elast:
Key	Description	Qty	21860-2111	21860-2113	21860-2115	21860-01-2115	21860-2165
1	Screw*	3	X3002-151F	X3002-151F	X3002-151F	X3002-151F	X3002-151F
2	Endcover	1	11154-0020	11154-0020	11154-0020	11154-0020	11154-0020
3	"O" Ring*	1	SP2000-58	SP2000-58	SP2000-58	SP2000-58	SP2000-58
4	Impeller*	1	9200-0011B	9200-0013B	12298-0015B	12298-0015B	23250-0065B
5	Body	1	22174-2100	22174-2100	22174-2100	22174-2100	22174-2100
6	Clamp	1	21163	21163	21163	21163	21163
7	Seal Assembly*	1	SP8021-0301B	SP8021-0301B	SP8021-0301B	SP8021-0301B	SP8021-0301B
8	Shim	2	22176	22176	22176	22176	22176
9	Nut	2	X3070-081F	X3070-081F	X3070-081F	X3070-081F	X3070-081F
10	Washer	2	X3080-081F	X3080-081F	X3080-081F	X3080-081F	X3080-081F
11	Screw	2	X3002-161F	X3002-161F	X3002-161F	X3002-161F	X3002-161F
12	Motor Assembly	1	22178	22178	22178	22178-0020	22178
Service Kit Contains*			SK320-02	SK320-0113	SK320	SK320-0123	SK320-0115T
Model 22218 As Above Except Key 12			22218-2111	22218-2113	22218-2115	22218-2115	22218-2165

SERVICE INSTRUCTIONS

Dis-Assembly

1. Remove screws (1), endcover and "O" ring. Withdraw impeller from body.
2. Loosen nut (9) on the motor side of the clamp and withdraw this assembly from motor.
3. Remove clamp assembly then seal seat and cup rubber from body.
4. Remove rotary seal and shims (7) from motor shaft.

Assembly

1. Place shims (7) on motor shaft. Smear shaft with lubricating oil and push rotary seal gently until it touches shaft shoulder. Fit cup rubber and seal seat into body.
2. Fit clamp onto motor spigot and then slide body into clamp and tighten nuts (9).
3. Fit impeller into lubricated body with a twisting motion in the same rotation as the motor.
4. Place "O" ring into body groove, place cover over body and secure with screws (1).

Inspect all parts for wear or damage and replace if necessary.

INSTALLATION DRAWING

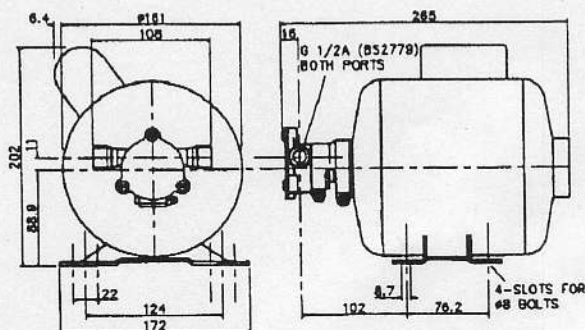

HEAD KIT 22218

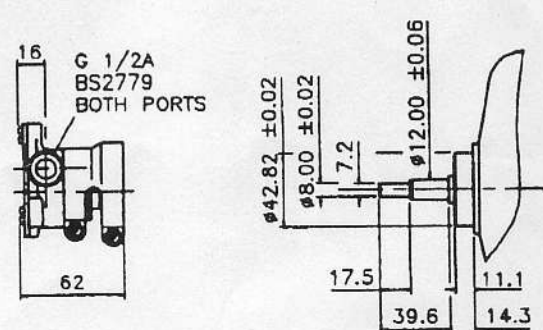

Suitable For Up to 3.0 Bar Differential Pressure

Motor Shaft Machining Details