

**JABSCO**[®]

Model 18590-Series

SELF-PRIMING MACERATOR PUMP

FEATURES

- Pump: Self-Priming Flexible Impeller with
Stainless Steel Wearplate
- Impeller: Jabsco Nitrile compound
- Macerator: Cast Bronze Cutter reduces particle size
to 1/8" maximum
- Seal: Lip Type
- Ports: Inlet – 1-1/2" Hose Barb and 1-1/2" N.P.T.
(Male)
Outlet – 1" Hose Barb
- Motor: Permanent Magnet Type, Fully
Enclosed, with Stainless Steel Shaft
- Weight: 7 lb (3,2 kg) Approx.

MODELS AVAILABLE

18590-0000	12 Volt
18590-0001	24 Volt
18590-0002	32 Volt

APPLICATION INFORMATION

The JABSCO 18590 series dc macerator pump unit is the ideal solution for emptying marine holding tanks when not in a discharge restricted area. The JABSCO macerator is self-priming to a six foot lift when impeller is wet, four foot when dry, and may be mounted in any convenient point in the waste discharge system. The macerator section grinds waste down to a particle size of 1/8" maximum so it can easily be pumped through a 1" ID discharge hose. The pump section is self-priming, permitting the unit to be mounted above the tank in a convenient location. (For optimal efficiency, locate pump as close to holding tank as possible.)

The macerator has an approximate flow rate of 12 GPM and will empty a typical 30 gallon holding tank in less than 3 minutes.

The 18590 series waste pump will macerate and pump all waste and tissue normally found in marine and recreational vehicle waste systems. IT WILL NOT HANDLE HARD SOLID OBJECTS, SANITARY NAPKINS OR RAGS.

Motors meet USCG Electrical standards (Title 33, Chapter I, Part 183; Subpart I) for IGNITION PROTECTION on gasoline powered vessels.

OPERATING INSTRUCTIONS

The macerator should be controlled by a momentary switch positioned close enough to the pump so it can be heard while operating. When the tank is empty there will be a change in pump noise (louder, higher frequency) at which time the macerator should immediately be switched off.

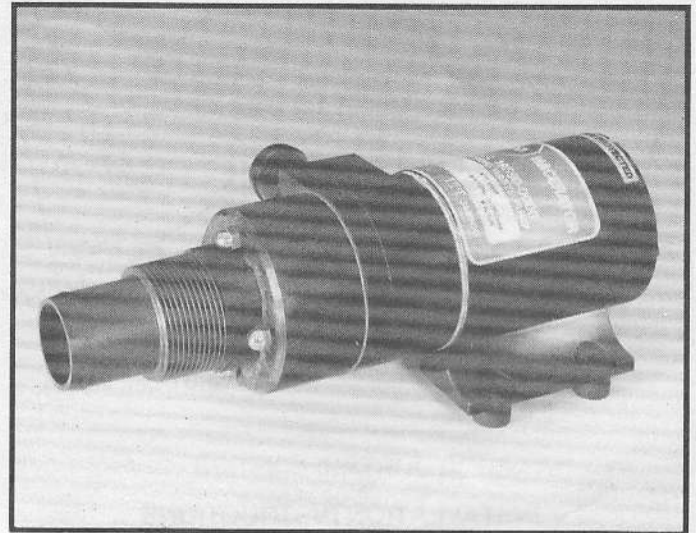

Model 18590-Series

The pumps should be used in accordance with EPA and USCG Marine Sanitation Regulations.

The macerator pump unit has been designed to handle waste, toilet tissue, and facial tissue. It will also handle solids such as cigarettes, cigars and chunks of soft fruits or vegetables less than 1" size. It will not pump solid objects like peach pits, rags, or sanitary napkins. The holding tank and pump should be flushed with several gallons of water after each pumpout. Do NOT run pump dry longer than 30 seconds or impeller and pump damage may result. Make sure the battery is fully charged. The dc motor is suitable only for intermittent duty and should not be run for more than 15 minutes continuously.

After long periods of nonuse, the flexible impeller may stick to the pump body preventing the macerator pump from turning freely. If this occurs, the impeller can be broken free by inserting a screwdriver in the slot in the motor shaft at the rear of the motor and rotating it clockwise a quarter turn or more.

MOTOR ILLUSTRATION

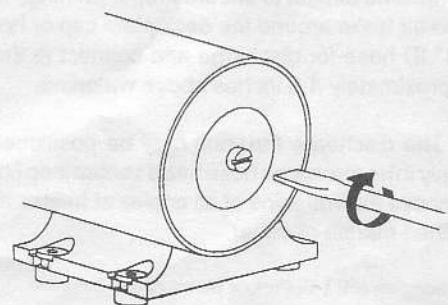

TYPICAL MARINE USES

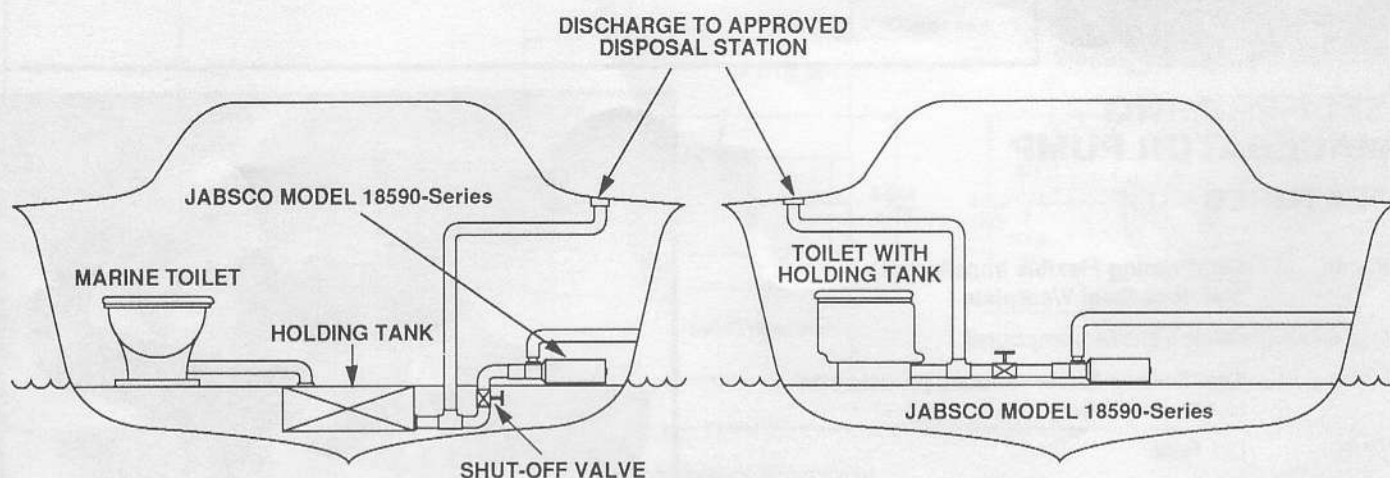

INSTALLATION INSTRUCTIONS

Locating the Pump: The JABSCO macerator is self-priming to a six foot lift when impeller is wet, four foot when dry, and may be mounted in any convenient point in the waste discharge system. It may be mounted in any position or angle without affecting performance. Use the rubber grommets provided to absorb vibration. Do not overtighten mounting screws. For optimal performance, mount the pump as close to tank as possible.

Plumbing Connections: Use 1-1/2" ID noncollapsible (radiator type) suction hose. Slip the hose over the inlet hose barb and secure it with two stainless steel hose clamps.

The macerator may also be screwed directly into a 1-1/2" N.P.T. tank flange or female pipe fitting. If attaching the inlet port to a pipe fitting it often requires removing the hose barb portion of the port with a hack-saw. If this is necessary, cut across the hose barb portion of the port about 1/8 inch away from the end of the pipe threads. Wrap port threads with a couple wraps of Teflon* tape and screw the pump assembly into the pipe fitting. Tighten hand tight, do not overtighten.

NOTICE: An air leak anywhere in the suction side of the plumbing system can cause extended dry running which may result in damage to the impeller and pump.

All suction connections must be airtight and free of sharp bends or restrictions. If a waste deck fitting is installed (for dockside pump-out), it too must be airtight to ensure proper priming. Make certain there are no air leaks around the deck plate cap or hose tail. Use minimum 1" ID hose for discharge and connect to thru-hull fitting located approximately 4-6 inches above waterline.

NOTICE: The discharge thru-hull may be positioned below the waterline only if the discharge hose has a vented loop fitting installed at least 8" above the waterline at all angles of heel or trim. Consult with a qualified marine plumber.

WIRING

NOTICE: Correct motor polarity (orange to positive, black to negative) is important. Reverse polarity can damage motor and void warranty.

Full voltage at the motor is required to properly operate the macerator. It must be wired in a circuit independent of all other accessories.

Use stranded copper wire of the correct size (determined from the electrical specifications chart) to connect the macerator to the power source. **An appropriate size fuse or equivalent circuit breaker (determined from electrical specifications chart) must be installed in the positive power lead within seven inches of the power source.** Connect the positive lead to a heavy-duty momentary switch (see required switch amperage rating in electrical specifications chart) positioned close enough to the macerator so the operator can hear the macerator while it is running. Extend the positive lead from the switch to the macerator and connect it to the orange (positive) motor lead. Connect the black (negative) motor lead to the negative side of the battery or grounded buss bar.

ELECTRICAL SPECIFICATIONS

VOLTAGE	AMP RATING	FUSE SIZE	WIRE SIZE PER FEET OF RUN*				
			0-10'	10'-15'	15'-25'	25'-40'	40'-60'
12 Vdc	16	25	#12	#10	#10	#8	#6
24 Vdc	8	15	#16	#14	#12	#10	#10
32 Vdc	6	10	#16	#16	#14	#14	#12

* Length of run is total distance from power source to product and back to ground.

* Teflon is a trademark of E.I. DuPont de Nemours and Company

EXPLODED VIEW

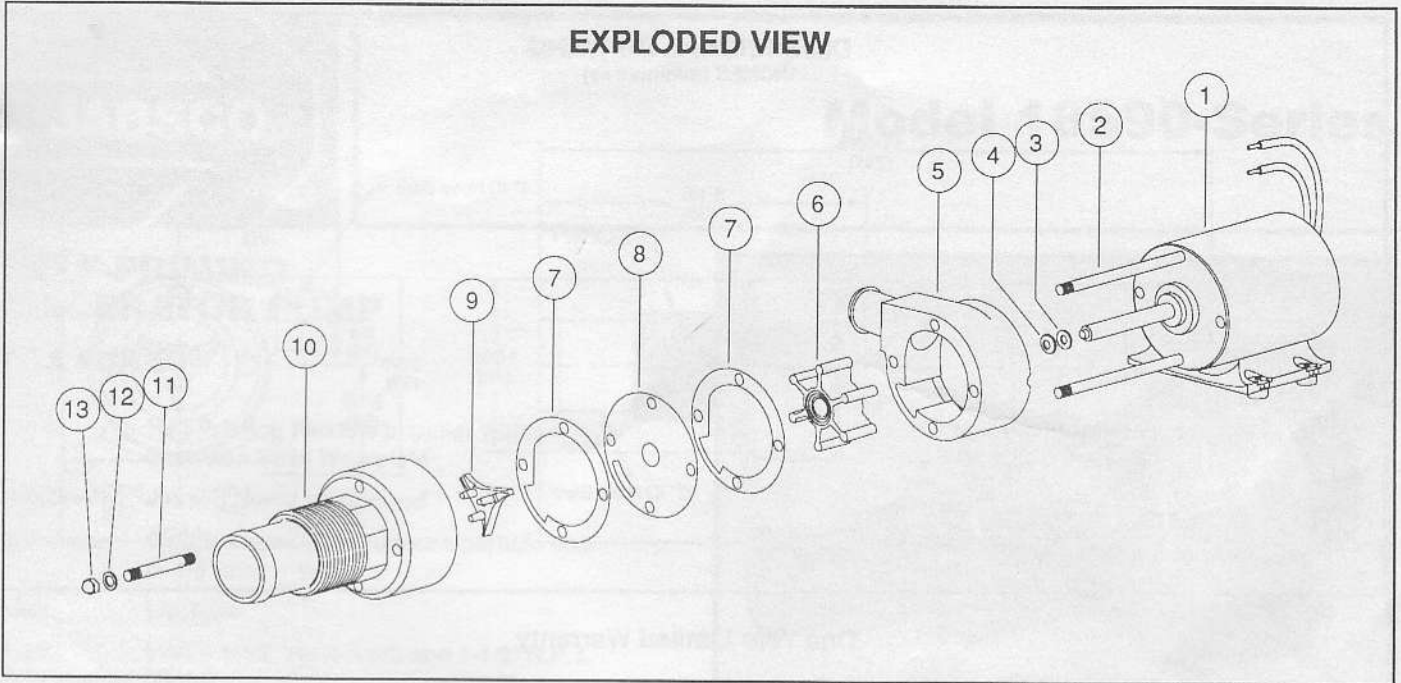

PARTS LIST

SERVICE INSTRUCTIONS

18590-Series

Key	Description	Part No.	Qty. Req.
1	Motor Sub-Assembly-12 volt Motor Sub-Assembly-24 volt Motor Sub-Assembly-32 volt	17246-0000 17246-0001 17246-0002	1 1 1
2	Stud	17288-0000	2
3	Slinger	6342-0000	1
4	Seal	1040-0000*	1
5	Body	18593-1000*	1
6	Impeller	6303-0003*	1
7	Gaskets (2 ea per kit)	18596-1000*	1
8	Wearplate	18597-1000	1
9	Cutter Plate	18595-1000	1
10	Macerator Housing	18594-1000	1
11	Stud	17288-0010*	2
12	Fiber Washer	91613-0140*	4
13	Acorn Nut	91085-0340	4
	Service Kit	18598-1000	1

1. Remove acorn nuts (Key 13) and inlet housing (Key 10).
2. Unscrew cutter plate from shaft by turning counterclockwise facing cutter blades. (Hold motor shaft behind plate with thin 9/32" (7mm) ignition wrench to prevent shaft from turning.)
3. Remove gaskets and wearplate; and slide pump assembly off mounting studs.
4. Replace seal, impeller, gaskets or other parts as necessary. To remove seal, push out evenly with screwdriver from impeller bore side of body. To reassemble seal, coat outside of metal case with a light coat of sealant and press into body with lip facing impeller. Press star retaining washer (with concave side up) into seal bore and against seal case. A light coating of grease should be applied to impeller bore and wearplate to aid initial dry startup.
5. Reassemble body, impeller, gaskets, wearplate, macerator housing and acorn nuts.

* These parts are supplied in 18598-1000 Service Kit.

HEAD CAPACITY TABLE*

Head Ft	GPM	AMPS		
		12 volt	24 volt	32 volt
Free flow	12.5	14.0	7.6	5.2
5	11.5	14.5	7.8	5.4
10	10.5	15.0	8.1	5.6
15	9.0	16.0	8.6	6.0
20	7.5	16.5	8.9	6.2

* Flow rates and amperage will vary slightly depending on pump loading (sanitation system design).

DIMENSIONAL DRAWING
INCHES (millimetres)

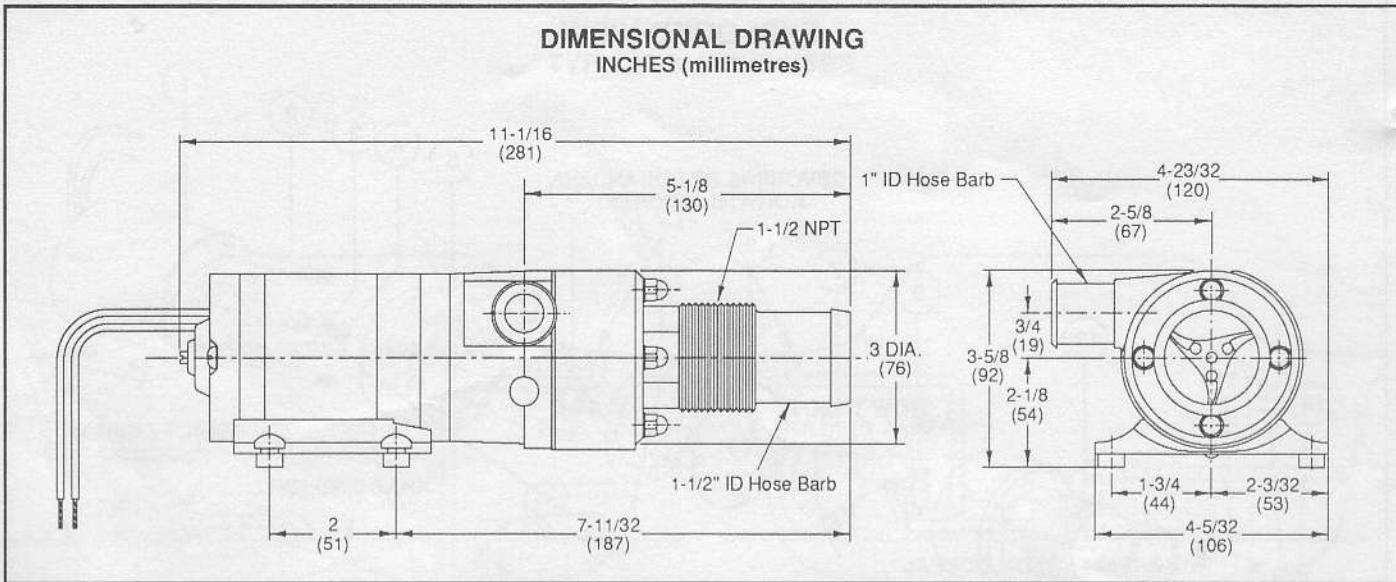

One Year Limited Warranty

A. LIMITED WARRANTY: ITT warrants that at the time of shipment, the products manufactured by ITT and sold hereunder shall be in conformity with applicable written specifications and descriptions referred to or set forth herein, free from defects in material and workmanship, merchantable, and suitable for a particular purpose, provided such is implied by State law under the circumstances of this sale.

B. WARRANTY ADJUSTMENT:

- ITT agrees to repair or furnish a replacement for, but not to remove or install, any product or component thereof which, within one (1) year from date of purchase, shall upon test and examination by ITT prove defective within the above warranty. Receipt verifying purchase date is required to obtain adjustment.
- Buyer shall notify ITT of any defect within this warranty no later than ninety (90) days after the defect is discovered.
- No product will be accepted for return or replacement without the prior written authorization of ITT. Upon such authorization, and in accordance with instructions from ITT, the product will be returned to ITT, shipping charges prepaid by Buyer. Products returned to ITT will be addressed as follows:

ITT JABSCO
1485 Dale Way

Costa Mesa, California 92626-3998

Or to such alternate locations as may be designated on the product, its container, or this sheet.

Repair or replacement made under this warranty will be shipped prepaid to Buyer.

C. EXCLUSIONS FROM WARRANTY AND LIMITATION OF LIABILITY:

- The foregoing warranty is limited solely as set forth herein and applies only for the period designated above.
- ITT SHALL NOT BE LIABLE FOR ANY LOSS, DAMAGE, SPECIAL OR CONSEQUENTIAL DAMAGE OF ANY KIND, WHETHER BASED UPON WARRANTY, CONTRACT, NEGLIGENCE, OR STRICT LIABILITY ARISING IN CONNECTION WITH THE SALE, USE, OR REPAIR OF THE PRODUCT.
- THE MAXIMUM LIABILITY OF ITT IN CONNECTION WITH THIS WARRANTY SHALL NOT IN ANY CASE EXCEED THE CONTRACT PRICE FOR THE PRODUCT CLAIMED TO BE DEFECTIVE OR UNSUITABLE.
- This warranty does not extend to any product manufactured by ITT which has been subjected to misuse, neglect, accident, improper installation, or use in violation of instructions furnished by ITT.
- This warranty does not extend to or apply to any unit which has been repaired or altered at any place other than ITT's factory, or by persons not expressly approved by ITT, nor to any unit the serial number, model number, or identification of which has been removed, defaced or changed.
- Components manufactured by any supplier other than ITT shall bear only that warranty made by the manufacturer of that product.
- This warranty applies to products defined as "consumer products" by the Consumer Product Warranties Act as from time to time amended.

D. CONSUMER RIGHTS: This warranty gives you specific legal rights, and you may have other rights which vary from state to state. Some states do not allow exclusion or limitation of damages.

STANDARD WARRANTY: If the products manufactured and sold hereunder are not Consumer Products, the warranty extended to Buyer shall be as set forth in subparagraphs (A), (B), and (C), EXCEPT THAT ALL EXPRESS OR IMPLIED WARRANTIES OR MERCHANTABILITY OR SUITABILITY FOR ANY PARTICULAR PURPOSE ARE EXCLUDED.

ITT Jabsco

ITT Fluid Technology Corporation

1485 Dale Way, P.O. Box 2158, Costa Mesa, CA 92628-2158

Tel: (714) 545-8251; Fax: (714) 957-0609

Bingley Road, Hoddesdon, Hertfordshire EN11 0BU, England

Tel: 0992-467191; Tlx: 263251 G; Fax: 0992-467132