

PRODUCT DATA

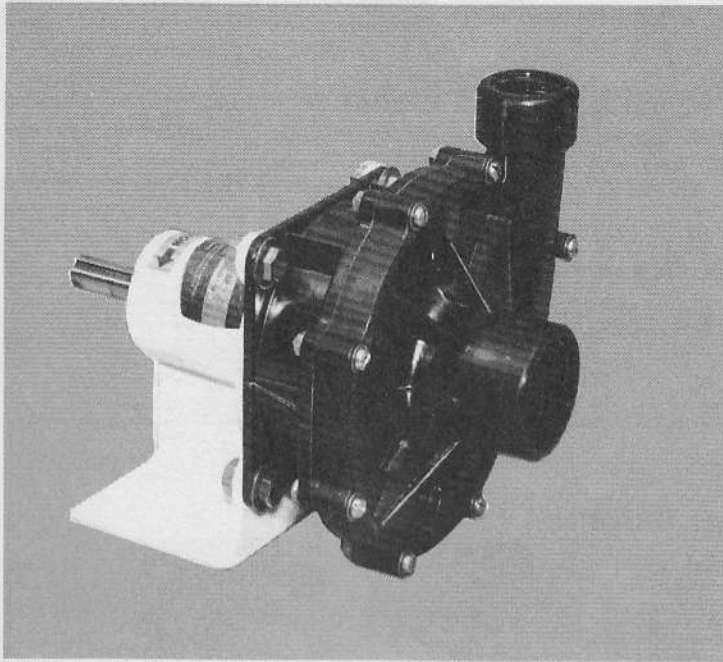

DESIGN FEATURES

Pump Material:	Glass Filled Epoxy
Impeller Design:	Semi-Open, 4½", 4", 3½"
Shaft Seal:	Balanced Mechanical: Carbon, Ceramic, and Viton
Seal Housing:	Optional Flush Gland Available
Suction Port:	1½" NPT Internal 2" ID Slip-on Hose External
Discharge Port:	1" NPT Internal 1¾" Slip-on Hose External
Maximum Fluid Temperature:	200°F. (93°C)
Bearing Housing:	Cast Iron
Shaft:	Carbon Steel
Bearings:	Ball Bearings
Weight:	8¾ lbs. (4 kgs.)

MODEL 17640-SERIES PEDESTAL

STANDARD MODELS

Impeller Size	Standard Seal Housing	Flush Gland Seal Housing
4½"	17640-1002	17640-1005
4"	17640-1008	17640-1011
3½"	17640-1014	17640-1017

APPLICATIONS

These pedestal pump units are designed especially for handling a variety of corrosive fluids. Their high quality and rugged construction make them suitable for a wide range of fluid circulation and transfer application within their hydraulic limitations. No metal parts come into contact with the fluid being pumped. The glass-filled epoxy pump handles corrosive fluids, photo chemicals, plating solutions, liquid fertilizers, caustic solutions, brine solutions and many others. See the "Jabsco Chemical Resistance Table" or consult the factory for complete listing of chemical applications.

INSTALLATION

INDUSTRIAL — fluid transfer, circulation, filtration, drainage, and water supplies (non-sanitary).

OEM — cooling or heating circulation equipment, distilled water circulation, laboratory equipment, electroplating filters, water treatment facilities, dispensers, laundry equipment, car washes, etc.

LOCATION — Pump may be mounted in any position. Volute may be removed and rotated to any one of eight different port positions to simplify piping. If the pump is to be mounted above the liquid level, provisions must be made to assure that the suc-

tion line and pump cavity is flooded before starting pump.

THIS PUMP WILL NOT SELF PRIME!

To prevent cavitation and obtain maximum service life, it is important that due consideration be given to the pump's NPSH characteristics. Factory application engineering assistance is available.

NOTE: For inlet pressure over 20 PSI, consult the factory for assistance.

PLUMBING — All piping to the pump must be supported independently of the pump. **CAUTION:** Use only plastic fittings in the suction and discharge ports. Keep suction and discharge

(Cont'd.)

INSTALLATION (Cont'd.)

lines as free of elbows and bends as possible. Line to suction port should be straight for a minimum length of 12" without elbows or reducers, to assure optimum performance. Suction line must be airtight to maintain prime. A flap type foot valve at the suction intake may be installed to retain liquid in system during shutdown. An auxiliary prime line may be installed by drilling and tapping boss on volute face (see dimensional detail).

FLUSH GLAND PLUMBING — Film leakage of fluid at the seal serves to lubricate the seal. Flush gland seal housing may be flushed to prevent accumulations of caustic or corrosive

fluid crystals. Plumb wash and drain lines with 1/8"-27 NPT fittings, to both sides of the seal housing flush gland. Flush pressure should not exceed 5 PSI.

MOTOR SELECTION — Refer to performance table and notes on specific gravity or viscosity to calculate proper horsepower requirement for drive motor.

BELT DRIVE — Proper belt tension will insure optimum pump performance and optimum belt and bearing life.

DIRECT DRIVE — A flexible coupling is recommended. Be sure there is

clearance between motor shaft and pump shaft when installing coupling. Mount and align pump and motor shaft before tightening coupling set screws.

MAXIMUM OPERATING SPEEDS — Consult factory for assistance before operating pump at speeds higher than those shown in performance tables.

OPERATION — Pump must be primed before starting. Continuous dry operation will damage seal. Start flow thru flush gland on models so equipped before starting pump motor. Failure to supply liquid to the flush gland will damage gland seal.

DIMENSIONAL DRAWING

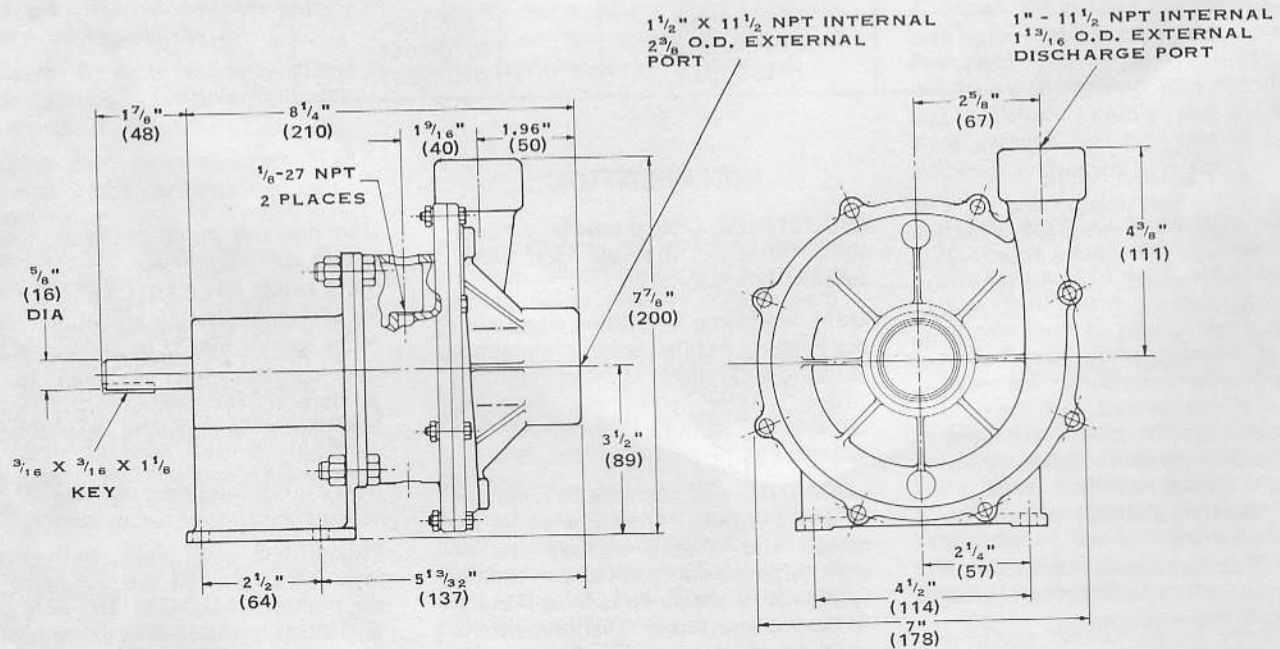

Parenthesis indicates millimeter equivalents.

PUMP PERFORMANCE CHARACTERISTICS

MODELS 17640-1002 and 17640-1005

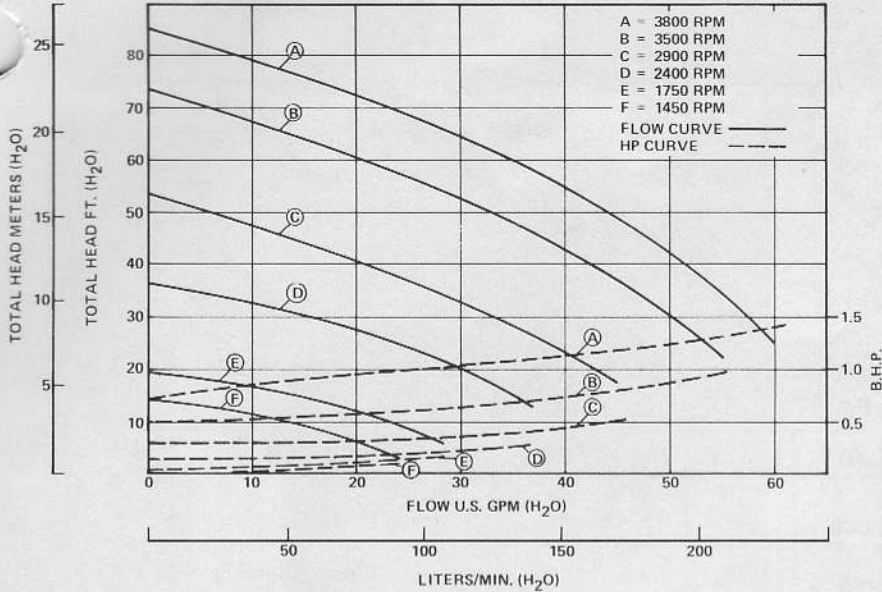

HORSEPOWER ADJUSTMENTS DUE TO CHANGES IN SPECIFIC GRAVITY

The performance curves on this data sheet are based on water at 68°F. The Head Curves may be read directly when the fluid in question has approximately the same viscosity as water. Note, however, that the horsepower requirement curve must be compensated according to the following instructions.

The specific gravity of a liquid other than water must be known to determine the required motor horsepower. The relationship between this power requirement and specific gravity is linear and may be expressed by the following formula:

$$\text{Water HP} \times \text{Specific Gravity} = \text{Required HP}^{**}$$

* For horsepower requirements, read adjacent curves.

** Consult the factor for assistance when the required horsepower to pump the liquid in question exceeds 1.5 HP rating on the curve for the appropriate size.

MODELS 17640-1008 and 17640-1011

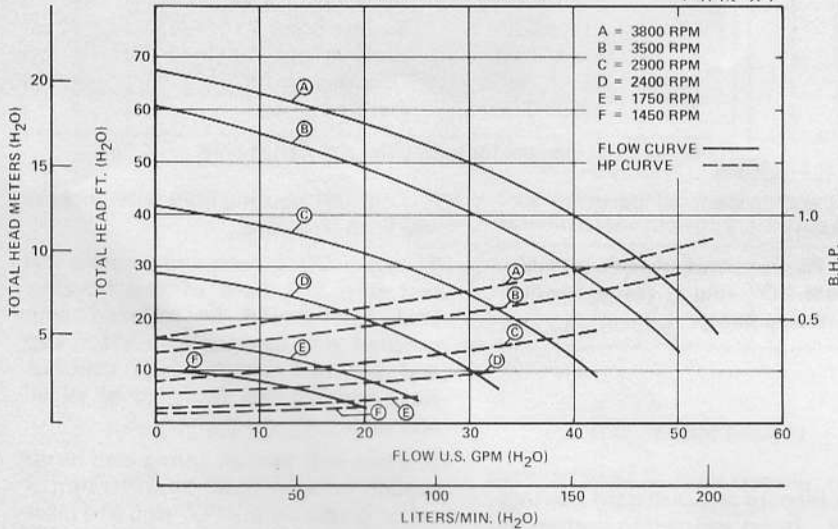

GAUGE CORRECTIONS DUE TO CHANGES IN SPECIFIC GRAVITY

Normally gauges are graduated in PSI. With changes in specific gravity, the gauge readings will change. If the discharge pressure is known for a liquid other than water, it must be converted to feet of water before the "water curves" can be used to determine the flow. Use this formula for conversion:

$$\frac{*PSI \times 2.31}{\text{Specific Gravity}} = \text{Feet of Water}$$

*Pressure measured at pump discharge port in PSI.

MODELS 17640-1014 and 17640-1017

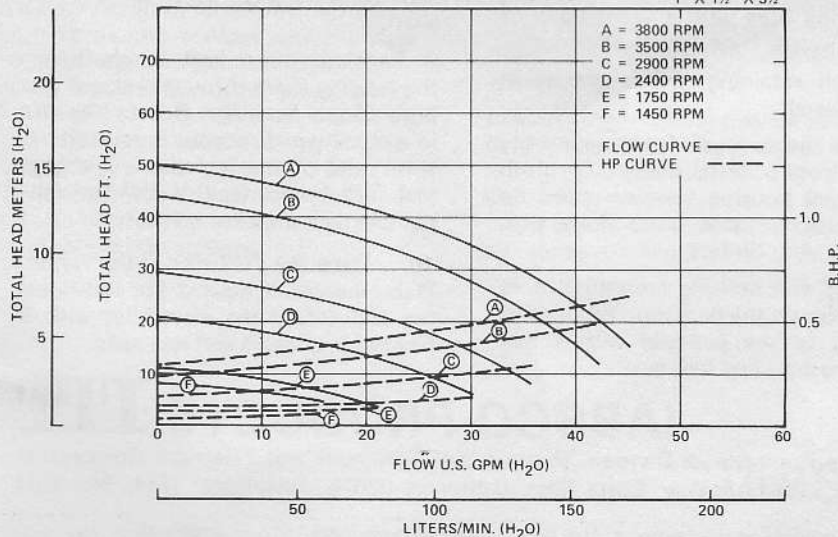

The converted head figure may now be applied to the "water curves" in order to determine the flow. Remember, however, the curves indicate total head which means the sum of both inlet and discharge pressure.

VISCOSITY: Pump performance is directly affected when handling viscous liquids. A distinct increase in liquid HP, a reduction in head, and some reduction in capacity will occur with moderate and high viscosity fluids. When accurate information is required, performance tests under actual conditions should be conducted. It is recommended that fluid viscosity be limited to a maximum of 460 SSU or 100 Centipoise. Consult the factory for assistance when more viscous fluids must be handled.

EXPLODED VIEW

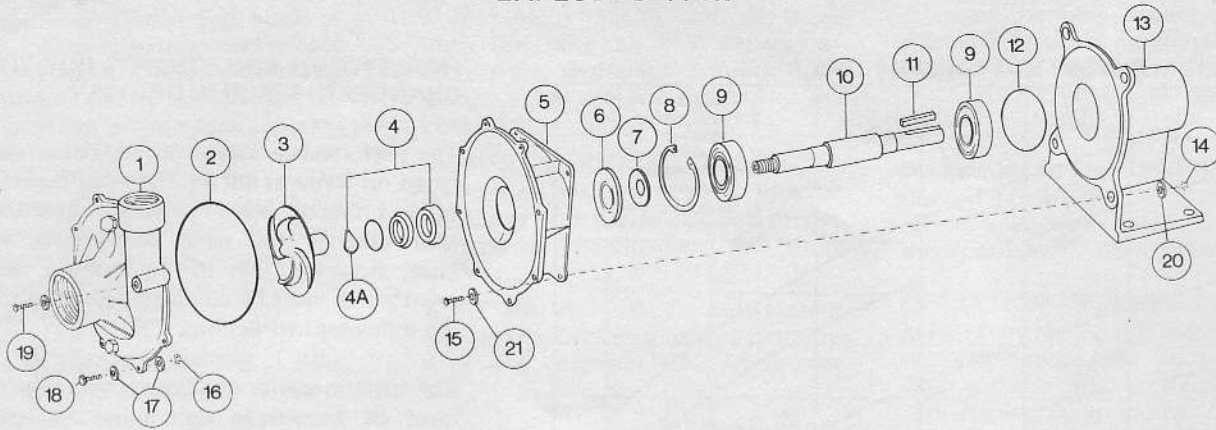

PARTS LIST

KEY	PART NUMBER	DESCRIPTION	QTY.	KEY	PART NUMBER	DESCRIPTION	QTY.
1	17826-0000	Volute	1	10	17666-0000	Shaft	1
2	92000-1180	"O" Ring	1	11	91402-0100	Key	1
3	17645-1000	Impeller, 4½"	1	12	98036-0290	Spring	1
	17645-1001	Impeller, 4"		13	17649-0000	Pedestal/Bearing Housing	1
	17645-1002	Impeller, 3½"		14	91085-0071	Hex Nut, 3/8"-16	4
4	18247-1000	Seal Assembly	1	15	91094-0191	Hex Bolt 3/8" - 16 X 1	4
4A	98021-0280	Seal Spring		16	91085-0261	Hex Nut, 10-32	8
5	17294-1000	Flush Gland Seal Housing	1	17	91602-0121	Flat Washer, 10-32	16
6*	92700-1020	Lip Seal	1	18	91045-0367	Machine Screw, 10-32 x 1¼"	7
7	3180-0000	Slinger	1	19	91045-0368	Machine Screw, 10-32 x 2"	1
8	91701-4400	Retaining Ring	1	20	91605-0091	Lock Washer, 3/8"	4
9	92600-0500	Bearing	2	21	91602-0260	Flat Washer, 3/8"	4

DISASSEMBLY

CAUTION: Pumps which have handled corrosive, caustic or toxic fluids should be drained and completely flushed prior to servicing.

1. Remove 8 bolts securing volute to seal housing. Remove "O" ring from groove in volute.
2. Prevent shaft from turning. Turn impeller in a counter-clockwise direction and remove.
3. Dislodge seal face and "O" ring from recess around impeller boss. Dislodge seal seat and cup from seal housing with a hooked wire. Be careful not to damage seal housing.
4. Remove 4 bolts securing seal housing to pedestal. Separate seal housing from pedestal. On flush gland seal housing versions, dislodge lip seal in the bore at the pedestal side of the housing.
5. Remove bearing retaining ring with snap ring pliers.
6. Press shaft and bearing assembly from pedestal housing. Press bearings from shaft.
7. Remove spring from bottom of bearing bore.

8. Clean and inspect all parts for excessive wear.

NOTE: Replacement of seal assembly and volute "O" ring is recommended when servicing pump.

ASSEMBLY

1. Press inboard and outboard bearings on shaft. Insert spring into bottom of bearing bore, concave side toward pump end.
2. Press bearing and shaft assembly into bearing bore with threaded end of shaft towards large flange of pedestal.
3. Install retaining ring in groove in the pedestal.
4. Place slinger on shaft approximately 3/16" from pedestal flange. On flush gland seal housing versions, press lip seal into rear seal bore, flush with housing, with lip facing in.
5. Align seal housing mounting holes with holes on the pedestal. Secure seal housing to the pedestal with 4 hex bolts, washers and hex nuts.

6. Coat seal housing bore with abrasive free soap solution.

7. Install Viton boot and ceramic seal seat into seal bore of seal housing. Seal seat should be installed with notched side inserted into Viton cup and polished ceramic seat exposed. Keep ceramic seal face free of all oil and soap.

8. Place seal tension spring into recess around impeller boss. Put light film of oil or grease on the "O" ring and place "O" ring around carbon ring. Slide carbon seal on to impeller boss and into recess, "O" ring first. Rotate ring slightly to engage tangs of impeller shaft.

9. Carefully insert impeller shaft over the bearing shaft through seal seat and bore of seal housing. Rotate impeller in a clockwise direction on to shaft. A firm twist of the impeller will engage seal seat against face of seal and adequately lock impeller on shaft.

10. Place the "O" ring in the volute. Place the volute against the seal housing and secure the assemblies with 8 hex bolts, washers and hex nuts.

JABSCO PRODUCTS **ITT**

Marine and Recreation Components Division, International Telephone and Telegraph Corporation
1485 Dale Way, Costa Mesa, California 92626, Telephone: (714) 545-8251