

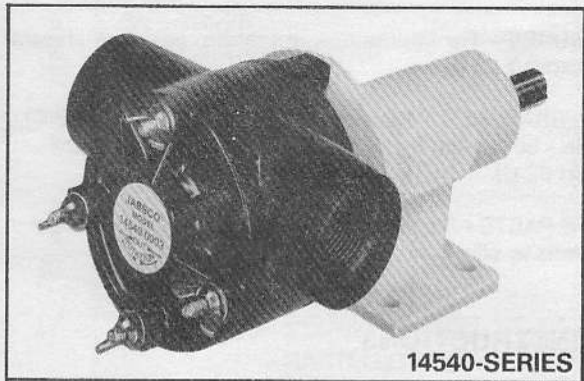

Models 14540-SERIES 14510-SERIES

Models 14540-SERIES, 14510-SERIES



14540-SERIES



14510-SERIES

SELF-PRIMING PUMPS

FEATURES

- Pump Series No.:** 14540-Series Pedestal Mounted
14510-Series Motor Pump Unit
- Body:** Glass-filled Epoxy
- Impeller:** Neoprene, Nitrile or Viton*
- Shaft Seal:** Mechanical, Carbon-on-Ceramic, Nitrile
- Ports:** 1" NPT Internal
- Shaft:** 316 Stainless Steel, Hastelloy "B",
or Titanium
- Motor:** 115 Vac, Single Phase, 60 Hz, 1 HP,
1725 RPM, TEFC, overload protected,
capacitor start. Three-pronged
grounded plug.
- Weight:** 14540-Series 8½ lb. (3,8 kg)
14510-Series 37½ lb. (17,1 kg)

VARIATIONS AVAILABLE

MODEL	DESCRIPTION
14540-0001	Stainless Steel Shaft
14510-0001	Neoprene Impeller
14540-0003	Stainless Steel Shaft
14510-0003	Nitrile Impeller
14540-0004	Stainless Steel Shaft
14510-0004	Viton Impeller Viton O-Rings Viton, Carbon/Ceramic Seal
14540-0021	Hastelloy B Shaft
14510-0021	Neoprene Impeller
14540-0023	Hastelloy B Shaft
14510-0023	Nitrile Impeller
14540-0024	Hastelloy B Shaft
14510-0024	Viton Impeller Viton O-Rings Viton, Carbon/Ceramic Seal
14540-0151	Titanium Shaft
14510-0151	Neoprene Impeller
14540-0153	Titanium Shaft
14510-0153	Nitrile Impeller
14540-0154	Titanium Shaft
14510-0154	Viton Impeller Viton O-Rings Viton, Carbon/Ceramic Seal

⚠ MOTOR WARNING

MOTOR CAN SPARK.
EXPLOSION & DEATH
CAN OCCUR.
DO NOT USE WHERE
FLAMMABLE VAPORS
ARE PRESENT

Designed for: "transfers," "circulation," "spill returns," "filtration," and "filling line" use. Easily handles pure solutions, foaming liquids, emulsions, suspended solids, gels and ferments. Because the plastic pump is resistant to corrosion and metallic contamination, it is widely used for pumping photo chemicals, plating compounds, lab solutions, pharmaceuticals, cosmetics, weak acids, alkalis, liquid fertilizers, insecticides, dyes, detergents, waxes and many more. See the "Chemical Resistance Table" located in the ITT Jabsco Catalog to help you select the most suitable impeller and pump material.

1. **INSTALLATION** – Pedestal Mounted Pump may be mounted in any position. The rotation of the pump shaft determines the location of the pump's intake and discharge ports. Refer to end cover. Before starting, turn the pump shaft in the direction of the operating rotation.

Viton* is a trademark of E. I. Du Pont de Nemours and Company.

2. DRIVE – Belt or direct with flexible coupling for pedestal mounted unit. Clearance should be left between drive shaft and pump shaft when installing coupling. Always mount pump and align drive shaft before tightening the coupling set screw. A capacitor start type motor must be used.
3. SPEEDS – Pedestal Mounted Pump - 100 RPM to the maximum shown in the performance table. For longer pump life, operate at lowest possible speeds.
4. SELF-PRIMING – Primed at low or high speeds. For vertical dry suction lift of 15 feet, a minimum of 1750 RPM is required. Pump will produce suction lifts up to 22 feet when wetted. BE SURE SUCTION LINES ARE AIRTIGHT OR PUMP WILL NOT SELF-PRIME.
5. RUNNING DRY – Unit depends on liquid pumped for lubrication. DO NOT RUN DRY FOR MORE THAN 30 SECONDS. Lack of liquid will damage the impeller.
6. DISCHARGE LINE – When transferring liquids further than 25 feet, use one size larger discharge line than discharge opening.
7. NOTICE – If corrosive fluids are handled, pump life will be prolonged if flushed with water after each use or after each work day. Consult ITT Jabsco Chemical Resistance Guide (available from the factory) or the factory for further information.
8. PRESSURES – For continuous operation, pressure should not exceed 20 psi.
9. TEMPERATURES – Neoprene - 45° to 180°F (7° to 82°C), Nitrile - 50° to 180°F (10° to 82°C), Viton - 60° to 180°F, (15° to 82°C).
10. SPARE PARTS – A spare impeller and seal should be kept on hand to eliminate downtime.

DISASSEMBLY AND ASSEMBLY INSTRUCTIONS

• Disassembly Steps □ Assembly Steps

TO REPLACE IMPELLER

- Step # 1. • Remove wing nuts, washers and end cover.
- Step # 2. • Remove pump head from seal housing. Remove O-rings from body grooves.
- Step # 3. • Push impeller from body bore.
- Step # 4. □ Install new impeller in lubricated body bore by grasping hub and with a rotary motion push it into the body bore. Replace O-rings in body grooves.
- Step # 5. □ Position the body over the through bolts against the seal housing.
- Step # 6. □ Install end cover and secure with washers and wing nuts.

TO REPLACE SEAL ASSEMBLY

- Step # 7. • Follow steps 1 •, 2 •, and 3 •.
- Step # 8. • Remove seal housing. Insert screw driver through seal seat bore and pry seat and grommet from seal housing.
- Step # 9. • Remove drive sleeve from shaft. Remove seal and seal spring from drive sleeve.
- Step #10. □ Install seal spring on drive sleeve. Lubricate seal with water and slide on drive sleeve with carbon facing away from spring. Install drive sleeve on shaft.
- Step #11. □ Install ceramic seal seat in grommet with grooved face towards grommet. Lubricate outer grommet surface with water and push seal seat assembly into seal housing with ceramic seal facing out of seal seat bore. Pedestal units only (14540-SERIES) check to make sure there are two washers on each through bolt next to pedestal. Assemble seal housing over through bolts so seal and seat faces contact.
- step #12. □ Assemble impeller, body, and end cover as in steps 4 □, 5 □, and 6 □.

TO SERVICE BEARING HOUSING (14540-SERIES)

- Step #13. • Follow steps 1 •, 2 •, 3 •, 8 •, and 9 •.
- Step #14. • Use a thin screw driver blade to pry inner bearing seal from pedestal. Use retaining ring pliers to remove retaining ring.
- Step #15. • Press on drive end of shaft to remove shaft and bearing assembly from pedestal.
- Step #16. • Use thin screw driver blade to pry outer bearing seal from pedestal.
- Step #17. • Support inner face of one bearing and press shaft through and out of bearing. Reverse shaft, support inner face of second bearing and press shaft through and out of bearing.
- Step #18. □ Support inner race of ball bearing, press shaft through bearing until shaft shoulder bottoms firmly against bearing inner race. Reverse shaft and repeat procedure to assemble second bearing on shaft.
- Step #19. □ Push shaft and bearing assembly into bearing housing from body end, secure with retaining ring in housing.
- Step #20. □ Press inboard bearing seal in bearing housing with lip facing impeller bore.
- Step #21. □ Press outboard bearing seal in bearing housing with lip facing outwards.
- Step #22. □ Assemble balance of pump parts following steps 10 □, 11 □, and 12 □.

PARTS LIST

KEY	DESCRIPTION	QTY. REQ.	PEDESTAL VERSION		MOTOR PUMP UNITS
			MODEL 14540 PART NO.	QTY. REQ.	
1	WING NUT	4	91107-0030	4	91107-0030
2	WASHER	5	91601-0040	4	91601-0040
3	STUD	1	91090-0100		
4	STUD	2	91090-0110	2	91090-0110
5	END COVER	1	17434-0000	1	17434-0000
6	IMPELLER - NEOPRENE - NITRILE - VITON	1	14282-0001 14282-0003 14282-0004	1	14282-0001 14282-0003 14282-0004
7	O-RING - NITRILE - VITON	2	92000-0310 92000-0880	2	92000-0310 92000-0880
8	BODY	1	14934-0000	1	14934-0000
9	SEAL HOUSING	1	14533-0000	1	14533-0010
*10	SEAL ASSEMBLY STANDARD CARBON/CERAMIC, VITON	1	96080-0040 96080-0210	1 1	96080-0280 96080-0290
11	STUB SHAFT - STAINLESS STEEL - HASTELLOY "B" - TITANIUM			1	14513-0000 14513-0001 14513-0002
12	BEARING SEAL	2	496-0000		
13	RETAINING RING	2	18716-0000		
14	BALL BEARING	2	92600-0120		
15	BEARING HOUSING	1	1269-0000		
16	BOLT	2	91095-0240	2	91095-0240
17	SHAFT - STAINLESS STEEL - HASTELLOY "B" - TITANIUM	1	14538-0010 14538-0020 14538-0150		
18	KEY	1	91402-0110		
19	ADAPTOR			1	17433-0000
20	BOLT	1	91095-0140	2	91095-0140
21	MOTOR			1	18753-0165
22	NUT - ADAPTOR			1	91105-0030
23	BOLT - ADAPTOR			1	91095-0090
24	WASHER	2	14536-0000		
25	SET SCREW	1			91084-0354
26	SET SCREW	1			91084-0355

EXPLODED VIEW

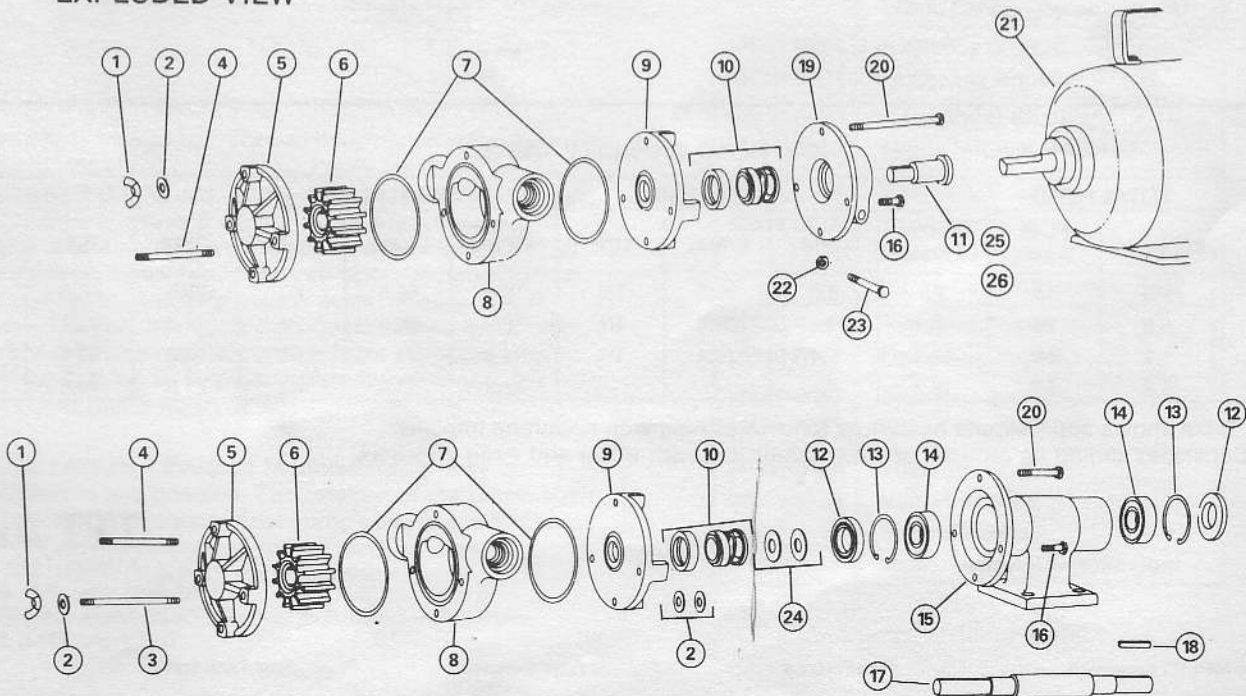

MODEL 14540-SERIES

DIMENSIONAL DRAWINGS
INCHES (MILLIMETRES)

ROTATION
DISCHARGE
DISCHARGE
ROTATION

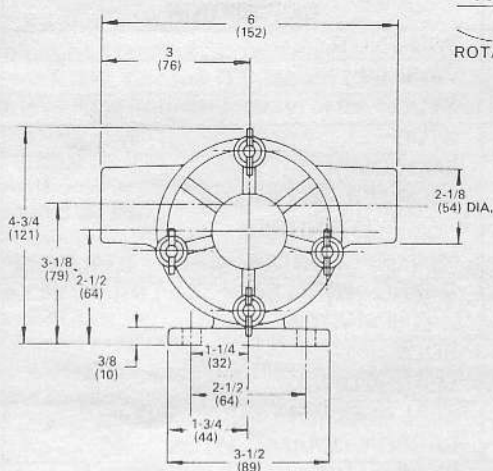
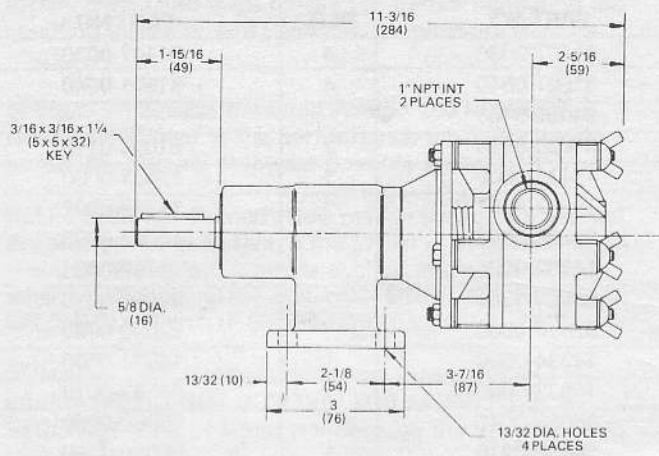

MODEL 14510-SERIES

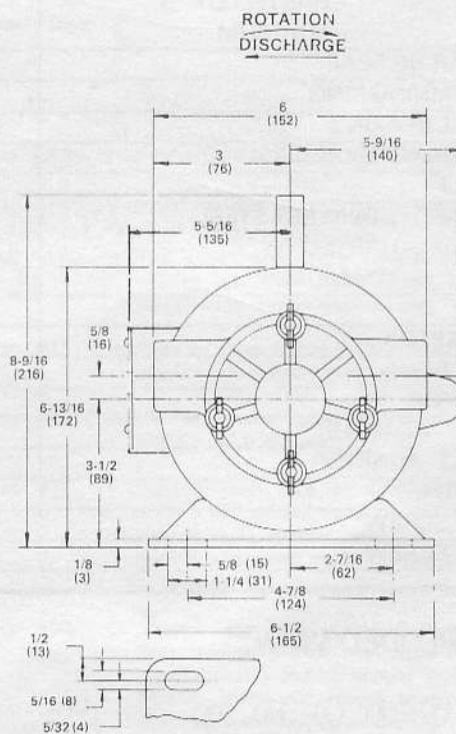
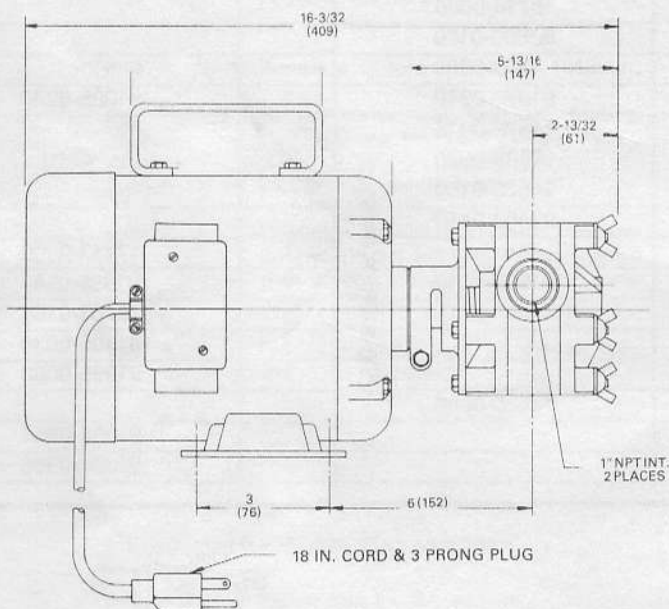

HEAD CAPACITY TABLE

TOTAL HEAD				SPEED 500 RPM			SPEED 1160 RPM			SPEED 1750 RPM		
PSI	Kg/Sq cm	Ft. of Water	Metres of Water	GPM	L/Min	H/P	GPM	L/Min	H/P	GPM	L/Min	H/P
4.3	0,3	10	3,0	8.0	30,3	1/6	16.5	62,5	1/3	25.5	96,5	3/4
8.7	0,6	20	6,1	7.5	28,4	1/4	16.0	60,5	1/3	24.6	93,1	3/4
17.3	1,2	40	12,2	5.4	20,4	1/4	14.3	54,1	1/3	23.0	87,1	3/4
26.0	1,8	60	18,3	-	-	-	12.8	48,4	1/2	21.0	79,5	1

NOTE: Table shows approximate head flow for new pumps with neoprene impeller. Capacities should be reduced approximately 10% with nitrile and viton impellers.

ITT JABSCO
A Unit of ITT Corporation
1485 Dale Way, P.O. Box 2158
Costa Mesa, CA 92628-2158
Telephone: (714) 545-8251