

JABSCO®

Models 12560-0001 12570-0001

Puppy Series



CAUTION: Do not operate with screws removed from motor case. Explosion resulting in personal injury, death or property damage may occur. Case openings must be sealed to avoid explosion and maintain ignition protected rating.

APPLICATION

Use for bilge pumping, live well circulation, washdown and general pumping requirements. If bilge water contains significant amount of oil, the standard impeller should be replaced with impeller #6303-0003 which is an oil-resistant nitrile material. With a wet impeller, pump will produce a suction lift of about 4 feet (1,2m) and a lift of 20 feet (6m) when primed. If the pump is dry, it will prime about 1.5 feet (0,47m). BE SURE SUCTION LINES ARE AIR TIGHT.

INSTALLATION

The pump must be mounted in a dry location — the motor is not waterproof and must not be submerged. **SELECTION OF A COOL, VENTILATED** location will generally extend pump motor life. The unit can be mounted in any desired position. It is best to mount so that water dripping from loose port connection will not wet the motor. The pump head may be mounted at 180 degree increments on the motor to allow change in flow direction.

SELF-PRIMING PUMPS

FEATURES

- Body:** Plastic
- Impeller:** Jabsco Neoprene compound
- Seal:** Lip type
- Ports:** Slip-on barbs for 5/8" I.D. hose
- Motor:** Permanent magnet type, fully enclosed, stainless steel shaft. Fuse and fuseholder included.
- Dimensions:** 3" (76 mm) high, 6-3/8" (162 mm) long, 4" (102 mm) wide
- Weight:** 4½ lbs (2 kg) approx.

Motor meets USCG Electrical Standards (Title 33, Chapter I, Part 183; Subpart I) for IGNITION PROTECTION on gasoline powered vessels.

WARNING: DO NOT PUMP SOLVENTS, THINNERS OR GASOLINE AS EXPLOSION MAY RESULT CAUSING PERSONAL INJURY OR DEATH.

Models 12560-0001, 12570-0001

VARIATIONS AVAILABLE

MODELS	VOLTAGE	AMP DRAW	FUSE SIZE
12560-0001	12 Volt dc	7	10
12570-0001	24 Volt dc	4	6

OPERATION

Flexible impeller pumps must *NOT* be run dry, as the pumped liquid is the lubricant for the impeller. Observe the outlet and shut off pump as soon as liquid stops flowing. An automatic level switch is convenient to control the pump.

NOTICE — If pump is idle for extended periods, the impeller may stick to the pump body, preventing motor rotation and causing blown fuses. To correct, remove end cover and impeller. Clean body and impeller, then lubricate with water or small amounts of grease before assembly.

Temperature of pumped liquid may be in the range of 45° – 160°F (10° – 70°C).

Pressure for normal operation should not exceed 20 feet of head (6,1m).

CAUTION: Motor runs hot; about 180°F (82°C) is a normal temperature. Prolonged contact during operation may cause a burn.

p.s.i.	TOTAL HEAD		CAPACITY	
	feet	metres	GPM	l/min
—	Open Flow	—	5.0	18,9
2.1	5	1,5	4.6	17,4
4.3	10	3,0	3.7	14,0
8.7	20	6,1	1.7	6,4

Table shows approximate Head-Flow for new pump.

PLUMBING CONNECTIONS

Pumps have slip-on fittings for 5/8" I.D. hose. Use hose that does not kink when bent and with sufficient wall thickness to prevent collapse when used on suction side of pump. Hoses should be routed so that some water will be retained in pump body to wet the impeller. Wetting the impeller aids in priming and extends impeller life. Use a strainer on the intake hose to stop trash and solids from going through the pump. All hoses must have airtight connections to enable faster priming.

ELECTRICAL CONNECTIONS

WARNING: IF PUMP IS OPERATED IN AN AREA CONTAINING FLAMMABLE VAPORS, WIRE LEADS MUST BE JOINED BY INSULATED MECHANICAL LOCKING CONNECTORS.

LOOSE OR INADEQUATE WIRE CONNECTIONS CAN SPARK RESULTING IN AN EXPLOSION. PROPERTY DAMAGE, INJURY OR DEATH MAY OCCUR.

Connect black wire to negative (-) terminal of battery. The orange wire with the fuse holder should run to an overload protected switch or circuit breaker, with a wire from switch or breaker to positive (+) terminal of battery. Electrical circuit must be independent of all other accessories. Failure to connect black wire to negative and orange wire to positive will result in backwards motor rotation and possible motor and pump damage. Correct motor rotation is clockwise looking at pump end of motor. Use proper wire size as determined by wire table elsewhere on this sheet. The proper fuse has been included in the fuse-holder. Should this fuse blow, replace with the same size fuse after determining reason for blown fuse.

When units have been idle or stored for long periods of time, the impeller may stick to the pump body causing fuse to blow. Remove end cover and manually free impeller. Replace end cover and fuse.

MINIMUM WIRE SIZES

WIRE LENGTH BATTERY TO MOTOR	12 VOLT dc	24 VOLT dc
1-10 ft. (3m)	#12	#16
11-20 ft. (6m)	#10	#16
21-30 ft. (9m)	# 8	#12

WIRING DIAGRAM

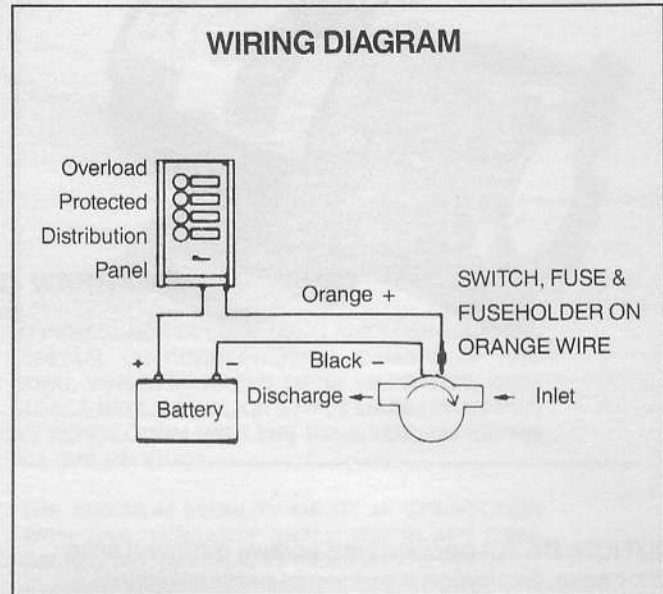

NOTICE: No warranty consideration will be given to pumps that are returned without the properly sized fuse and fuse holder supplied with the pump.

EXPLODED VIEW

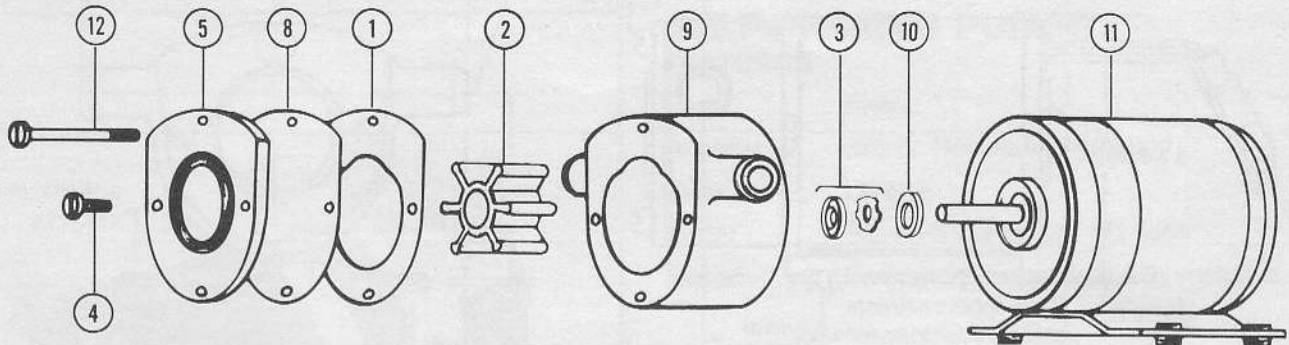

KEY	DESCRIPTION	PART NUMBER	QTY. REQ.
* 1	Gasket	12558-0000	1
* 2	Impeller†	6303-0001	1
* 3	Seal	1040-0000	1
4	Screw (End Cover)	91014-0020	2
5	End Cover	12555-0000	1
8	Wearplate	12557-0000	1
9	Body	12554-0000	1
10	Slinger	6342-0000	1
11	Motor		1
	12 Volt dc	98012-0020	
	24 Volt dc	98012-0030	
12	Screw (Mtr. to Body)	91014-0010	2
	Replacement Pump Head only	12590-0001	—
	Service Kit	90126-0001	

* Parts contained in Service Kit.

† 6303-0003 Oil resistant Nitrile Impeller available separately.

DISASSEMBLY

1. Remove top and bottom end cover screws and remove pump head from motor.
2. Remove remaining end cover screws.
3. Remove end cover, wearplate and gasket.
4. Withdraw impeller.
5. Pry seal retainer from seal cavity and press seal out of cavity from impeller bore side.

NOTE: Do not tamper with or disassemble motor.

MAINTENANCE

Check wires and connections to be sure corrosion is not adding additional resistance to the motor circuit and causing a low voltage condition *at the motor*. Low voltage can inhibit motor from starting and can cause fuse to blow. Full voltage should be available to prevent motor damage.

If pump is to be in freezing temperatures, drain by loosening end cover.

Service kits, or at least spare impellers, should be carried aboard to be assured of pumping capability.

ASSEMBLY

1. Lubricate seal and press into seal cavity, with open side of seal facing impeller. Center seal retainer (concave side up) in seal cavity and press firmly against seal using $\frac{1}{16}$ dia. dowel.
2. Install slinger on shaft $\frac{1}{16}$ from motor hub. Lubricate motor shaft.
3. Locate body on motor.
4. Align flat in impeller with motor shaft flat and install impeller into impeller bore.
5. Replace gasket, wearplate, and cover, and end cover screws.
6. Secure pump head to motor with long machine screws.

DIMENSIONAL DRAWINGS inches (millimeters)

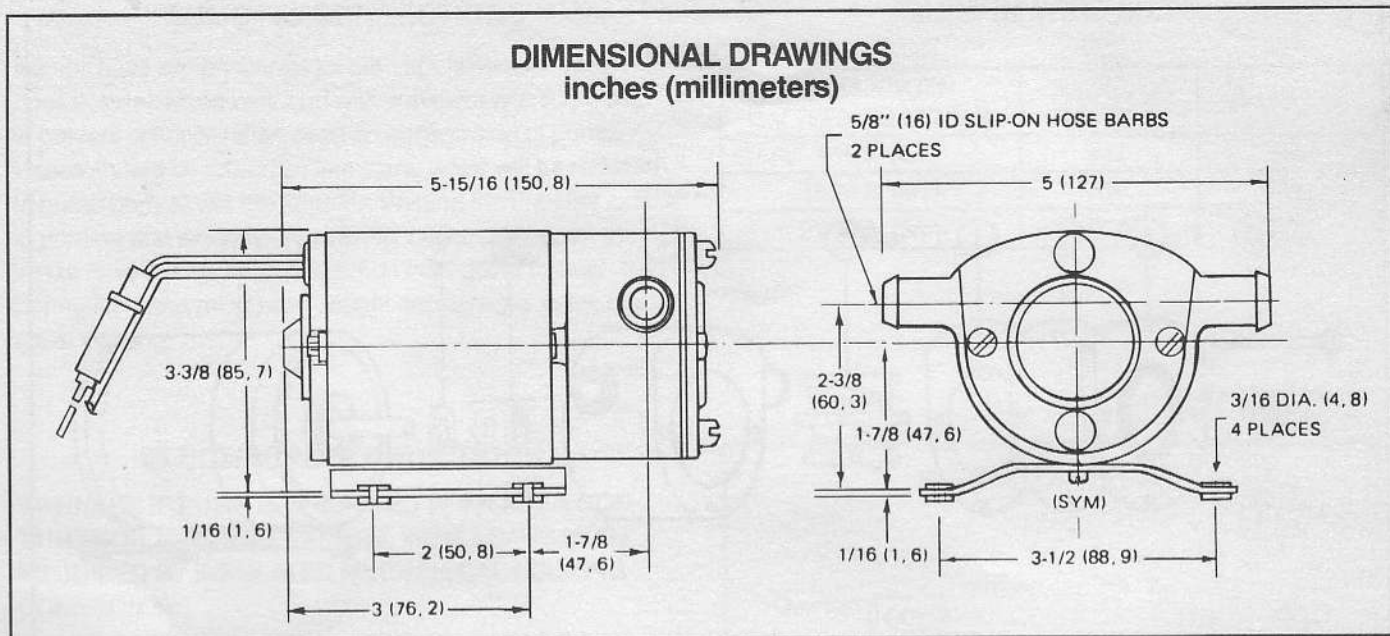

ONE YEAR LIMITED WARRANTY

A. WARRANTY: ITT warrants that at the time of shipment, the products manufactured by ITT and sold hereunder shall be in conformity with applicable written specifications and descriptions referred to or set forth herein, free from defects in material and workmanship, merchantable, and suitable for a particular purpose, provided such is implied by State law under the circumstances of this sale.

B. WARRANTY ADJUSTMENT:

1. ITT agrees to repair or furnish a replacement for, but not to remove or install, any product or component thereof which, within one (1) year from date of purchase, shall upon test and examination by ITT prove defective within the above warranty. Receipt verifying purchase date is required to obtain adjustment.
2. Buyer shall notify ITT of any defect within this warranty no later than ninety (90) days after the defect is discovered.
3. No product will be accepted for return or replacement without the prior written authorization of ITT. Upon such authorization, and in accordance with instructions from ITT, the product will be returned to ITT, shipping charges prepaid by Buyer. Products returned to ITT will be addressed as follows:

ITT JABSCO
1485 Dale Way
Costa Mesa, California 92626-3998

Or to such alternate locations as may be designated on the product, its container, or this sheet.

Repair or replacement made under this warranty will be shipped prepaid to Buyer.

C. EXCLUSIONS FROM WARRANTY:

1. The foregoing warranty is limited solely as set forth herein and applies only for the period designated above.

2. ITT SHALL NOT BE LIABLE FOR ANY LOSS, DAMAGE, SPECIAL OR CONSEQUENTIAL DAMAGE OF ANY KIND, WHETHER BASED UPON WARRANTY, CONTRACT, NEGLIGENCE, OR STRICT LIABILITY ARISING IN CONNECTION WITH THE SALE, USE, OR REPAIR OF THE PRODUCT.

3. THE MAXIMUM LIABILITY OF ITT IN CONNECTION WITH THIS WARRANTY SHALL NOT IN ANY CASE EXCEED THE CONTRACT PRICE FOR THE PRODUCT CLAIMED TO BE DEFECTIVE OR UNSUITABLE.

4. This warranty does not extend to any product manufactured by ITT which has been subjected to misuse, neglect, accident, improper installation, or use in violation of instructions furnished by ITT.

5. This warranty does not extend to or apply to any unit which has been repaired or altered at any place other than ITT's factory, or by persons not expressly approved by ITT, nor to any unit the serial number, model number, or identification of which has been removed, defaced or changed.

6. Components manufactured by any supplier other than ITT shall bear only that warranty made by the manufacturer of that product.

7. This warranty applies to products defined as "consumer products" by the Consumer Product Warranties Act as from time to time amended.

STANDARD WARRANTY: If the products manufactured and sold hereunder are not Consumer Products, the warranty extended to Buyer shall be as set forth in subparagraphs (a), (b), and (c), EXCEPT THAT ALL EXPRESS OR IMPLIED WARRANTIES OR MERCHANTABILITY OR SUITABILITY FOR ANY PARTICULAR PURPOSE ARE EXCLUDED.

ITT JABSCO

A Unit of ITT Corporation
1485 Dale Way, P.O. Box 2158
Costa Mesa, CA 92628-2158
Telephone: (714) 545-8251