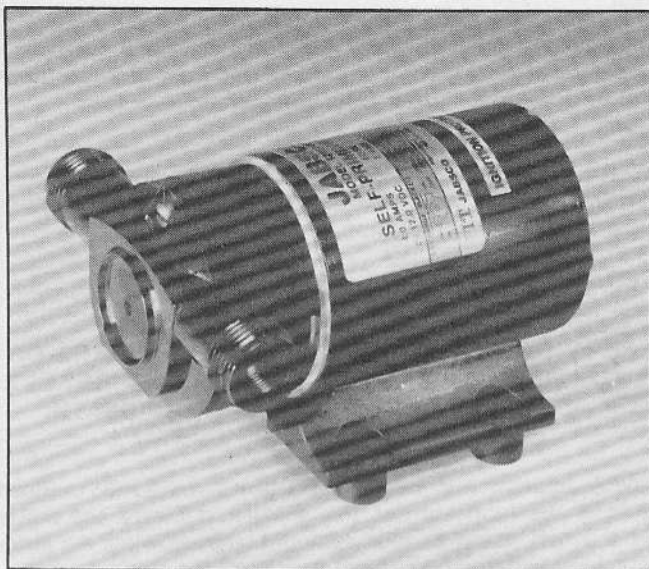

JABSCO®**Model 12460-0011**

Model 12460-0011

**SELF-PRIMING PUMPS****FEATURES**

- Body:** Phenolic-type plastic
Impeller: Jabsco compound
Seal: Lip type
Ports: 3/4" Garden hose external thread
 3/8" Pipe internal thread
Motor: Reversible permanent magnet, fully enclosed, stainless steel shaft
Dimensions: 3 3/8" (86 mm) High, 6 3/8" (163 mm) Long, 5-1/32" (128 mm) Wide
Weight: 4 lbs (1,8 kg) approx.

CAUTION: Do not operate with rivets removed from motor case. Explosion resulting in personal injury, death or property damage may occur. Case openings must be sealed to avoid explosion and maintain ignition protected rating.

Motor meets USCG Electrical Standards (Title 33, Chapter I, Part 183; Subpart I) for IGNITION PROTECTION on gasoline powered vessels.

APPLICATION

Use for bilge pumping, live well circulation, wash down and general pumping requirements. When bilge water contains significant amounts of oil, use impeller No. 14750-0003. For intermittent duty, motor may be reversed.* With a wet impeller, pump will produce a suction lift of about 4 feet (1,2m) and a lift to 15 feet (5m) when primed. BE SURE SUCTION LINES ARE AIRTIGHT.

PLUMBING CONNECTIONS

Pumps have external garden hose threads and internal 3/8" pipe threads. Use hose that does not kink when bent or collapse due to the suction of the pump. Arrange hoses to trap water in pump body to wet the impeller. Wetting the impeller aids in priming and extends impeller life. Use a strainer on the intake hose to prevent debris from entering pump. All hoses must have airtight connections. Use only plastic fittings on internal port threads.

INSTALLATION

The pump must be mounted in a dry location – the motor is not waterproof and must not be submerged. SELECTION OF A COOL location will generally extend pump motor life. The unit can be mounted in any desired position. The pump head may be rotated 180° to change direction of flow in preferred rotation (see wiring diagram). It is best to mount so that water dripping from loose port connection will not wet the motor.

*To prolong motor life, install pump so normal motor rotation is clockwise.

PSI	TOTAL HEAD		CAPACITY	
	FEET	METRES	GPM	L/MIN
2.1	5	1,5	1.8	6.8
4.3	10	3,0	1.7	6.4
8.7	20	6,1	1.4	5.3
13.0	30	9,1	1.0	3.8

Table shows approximate Head-Flow for new pump.

ELECTRICAL CONNECTIONS



IF PUMP IS OPERATED IN AN AREA CONTAINING FLAMMABLE VAPORS, WIRE LEADS MUST BE JOINED BY INSULATED MECHANICAL LOCKING CONNECTORS.

LOOSE OR INADEQUATE WIRE CONNECTIONS CAN SPARK RESULTING IN AN EXPLOSION. PROPERTY DAMAGE, INJURY OR DEATH MAY OCCUR.

Connect black wire to negative (-) terminal of battery. The orange wire with the fuse holder should run to an overload protected switch or circuit breaker, with a wire from switch or breaker to positive (+) terminal of battery. Electrical circuit must be independent of all other accessories. A reversing switch (polarity swapping) may be used to reverse pump for intermittent duty cycles. Preferred motor rotation is clockwise looking at shaft end of motor.* Use proper wire size as determined by wire table elsewhere on this sheet. The proper fuse has been included in the fuse holder. Should this fuse blow, replace with the same size fuse after determining and correcting cause of blown fuse.

WIRING DIAGRAM

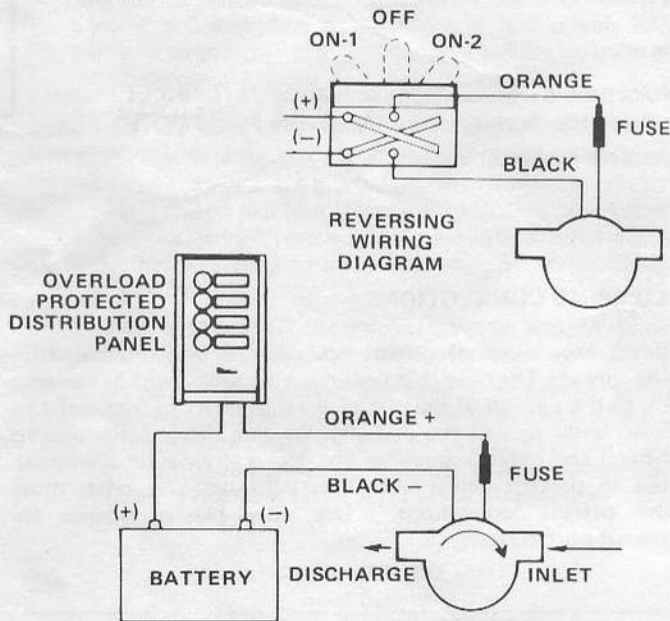

AMPERE DRAW

Model No.	Voltage	Amp Draw	Fuse Size
12460-0011	12 Vdc	4	7 amp Slow Blow

*To prolong motor life, install pump so normal motor rotation is clockwise.

MINIMUM WIRE SIZES

Connection Length Between Battery and Motor	12 Vdc
1-10 ft. (3m)	# 14
11-20 ft. (6m)	# 12
21-30 ft. (9m)	# 10

CAUTION: To prevent motor damage, use only multi-strand copper wire in size recommended. DO NOT use ordinary lamp cord or other substitutes. Use 7 amp slow blow fuse.

NOTICE: No warranty consideration will be given to pumps that are returned without the properly sized fuse and fuse holder supplied with the pump.

OPERATION



DO NOT PUMP SOLVENTS, THINNERS OR GASOLINE AS EXPLOSION MAY RESULT CAUSING PERSONAL INJURY OR DEATH.

Flexible impeller pumps must NOT be run dry, as the pumped liquid is the lubricant for the impeller. Observe the outlet and shut off pump as soon as liquid stops flowing. An automatic level switch is convenient to control the pump.

The pump cannot run against a closed outlet such as encountered when using a garden hose type shut-off nozzle.

Temperature of pumped liquid may be in the range of 45° - 160°F (10° - 70°C).

Pressure for normal operation should not exceed 30 feet of head (13 psi).

EXPLODED VIEW

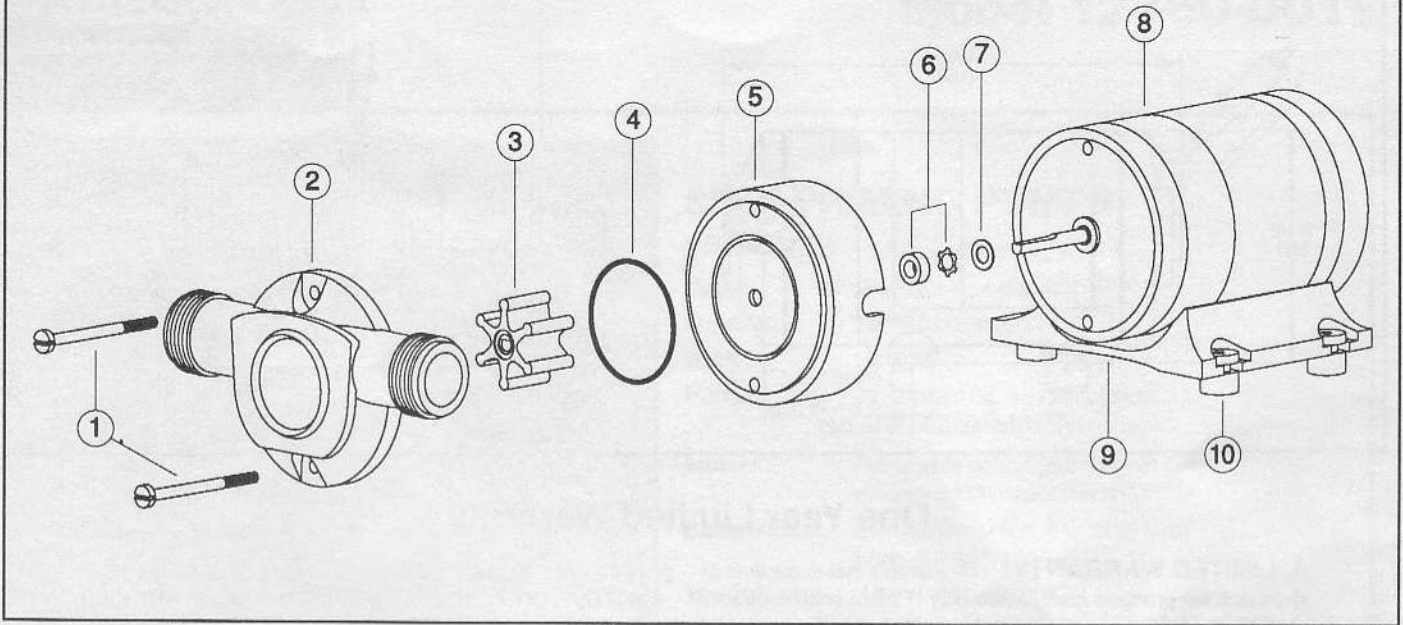

PARTS LIST

KEY	DESCRIPTION	PART NUMBER	QTY.
1	Screw (Body)	91003-0120	2
2	Body	12375-0000	1
3	*Impeller, Neoprene	14750-0001	1
	††Impeller, Nitrile	14750-0003	1
4	*O-Ring	92000-0750	1
5	Seal Housing	12314-0000	1
6	*Seal Assembly	1040-0000	1
7	Slinger	6342-0000	1
8	Motor	98012-0020	1
9	†Base	6357-0020	1
10	†Grommet	92900-0120	4
	Replacement Pump Head	12317-0000	—
	Service Kit	90158-0051	—

*Parts Contained in Service Kit

†Parts Supplied with Motor

††Use Nitrile impeller for water containing significant amounts of oil.

DISASSEMBLY

1. Remove body screws, body, and impeller.
2. Withdraw impeller from body bore.
3. Remove Seal Housing from motor and shaft.
4. Pry seal retainer from seal cavity and press seal out of cavity from impeller side.

NOTE: Do not tamper with or disassemble motor.

ASSEMBLY

1. Press seal into seal cavity with lip towards impeller, until it bottoms firmly against shoulder. Center seal retainer (concave side up) in seal cavity and press firmly against seal, using 11/16 in. diameter dowel.
2. Lubricate motor shaft and install seal housing on motor.
3. Install impeller in body, with a counterclockwise rotation.
4. Attach body to seal housing and motor with body screws.

MAINTENANCE

Check wires and connections to be sure corrosion is not adding additional resistance to the motor circuit and causing a low voltage condition at the motor. Low voltage can inhibit starting and cause fuse to blow. Full voltage should be available to prevent motor damage.

If pump is idle for extended periods, the impeller may stick to the pump body, preventing motor rotation and causing blown fuses. To correct, remove pump body and impeller. Clean body and impeller, then lubricate with water or small amounts of grease before assembly.

If pump is to be in freezing temperatures, drain by loosening body screws.

A service kit, or at least a spare impeller, should be kept on hand to be assured of pumping capability.

DIMENSIONAL DRAWING
INCHES (MILLIMETRES)

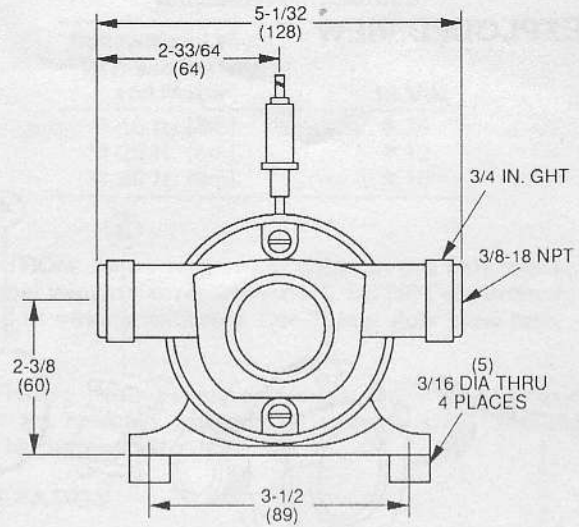
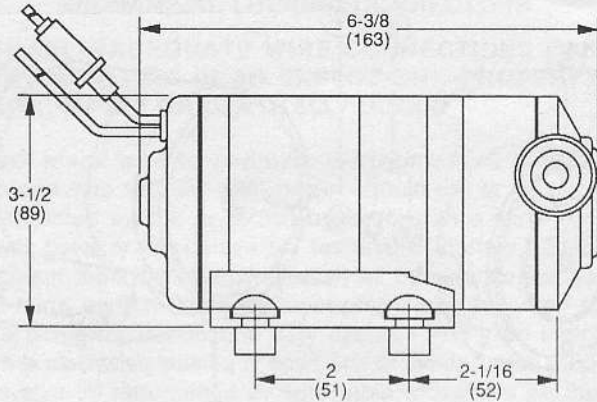

One Year Limited Warranty

A. LIMITED WARRANTY: ITT warrants that at the time of shipment, the products manufactured by ITT and sold hereunder shall be in conformity with applicable written specifications and descriptions referred to or set forth herein, free from defects in material and workmanship, merchantable, and suitable for a particular purpose, provided such is implied by State law under the circumstances of this sale.

B. WARRANTY ADJUSTMENT:

1. ITT agrees to repair or furnish a replacement for, but not to remove or install, any product or component thereof which, within one (1) year from date of purchase, shall upon test and examination by ITT prove defective within the above warranty. Receipt verifying purchase date is required to obtain adjustment.
2. Buyer shall notify ITT of any defect within this warranty no later than ninety (90) days after the defect is discovered.
3. No product will be accepted for return or replacement without the prior written authorization of ITT. Upon such authorization, and in accordance with instructions from ITT, the product will be returned to ITT, shipping charges prepaid by Buyer. Products returned to ITT will be addressed as follows:

ITT JABSCO
1485 Dale Way
Costa Mesa, California 92626-3998

Or to such alternate locations as may be designated on the product, its container, or this sheet.

Repair or replacement made under this warranty will be shipped prepaid to Buyer.

C. EXCLUSIONS FROM WARRANTY AND LIMITATION OF LIABILITY:

1. The foregoing warranty is limited solely as set forth herein and applies only for the period designated above.

2. ITT SHALL NOT BE LIABLE FOR ANY LOSS, DAMAGE, SPECIAL OR CONSEQUENTIAL DAMAGE OF ANY KIND, WHETHER BASED UPON WARRANTY, CONTRACT, NEGLIGENCE, OR STRICT LIABILITY ARISING IN CONNECTION WITH THE SALE, USE, OR REPAIR OF THE PRODUCT.

3. THE MAXIMUM LIABILITY OF ITT IN CONNECTION WITH THIS WARRANTY SHALL NOT IN ANY CASE EXCEED THE CONTRACT PRICE FOR THE PRODUCT CLAIMED TO BE DEFECTIVE OR UNSUITABLE.

4. This warranty does not extend to any product manufactured by ITT which has been subjected to misuse, neglect, accident, improper installation, or use in violation of instructions furnished by ITT.

5. This warranty does not extend to or apply to any unit which has been repaired or altered at any place other than ITT's factory, or by persons not expressly approved by ITT, nor to any unit the serial number, model number, or identification of which has been removed, defaced or changed.

6. Components manufactured by any supplier other than ITT shall bear only that warranty made by the manufacturer of that product.

7. This warranty applies to products defined as "consumer products" by the Consumer Product Warranties Act as from time to time amended.

D. CONSUMER RIGHTS: This warranty gives you specific legal rights, and you may have other rights which vary from state to state. Some states do not allow exclusion or limitation of damages.

STANDARD WARRANTY: If the products manufactured and sold hereunder are not Consumer Products, the warranty extended to Buyer shall be as set forth in subparagraphs (A), (B), and (C), EXCEPT THAT ALL EXPRESS OR IMPLIED WARRANTIES OR MERCHANTABILITY OR SUITABILITY FOR ANY PARTICULAR PURPOSE ARE EXCLUDED.

ITT Jabsco

ITT Fluid Technology Corporation
1485 Dale Way, P.O. Box 2158, Costa Mesa, CA 92628-2158
Tel: (714) 545-8251; Fax: (714) 957-0609
Bingley Road, Hoddesdon, Hertfordshire EN11 0BU England
Tel: 0992-467191; Tlx: 263251 G; Fax: 0992-467132