

# JABSCO® PUMPS

Self Priming Pumps

# MODELS: 11860-Series 11870-Series

Electro-Magnetic Clutch Units-12 Volt D.C.  
Product Data

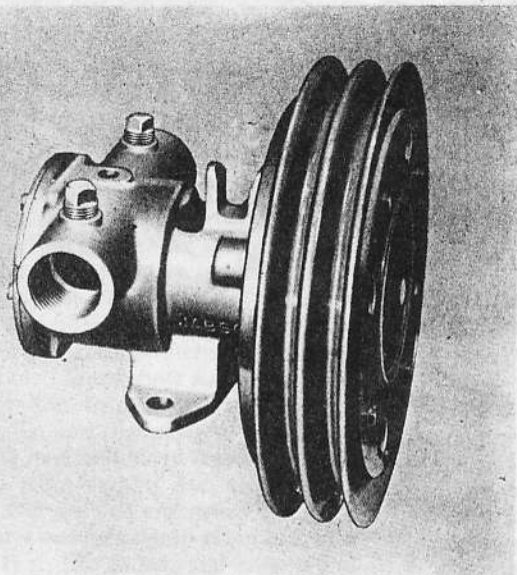

Models: 11860-0004

## DESIGN FEATURES

Body:	<b>Bronze</b>
Impeller:	<b>Neoprene or Nitrile</b>
Shaft:	<b>Brass</b>
Ports:	<b>11860-0001, 1" NPT, 11870-0001, 1 1/4" NPT</b>
Seal:	<b>Carbon-Ceramic, Face Type</b>
Bearings:	<b>Sealed Ball Bearings</b>
Shipping Weight:	<b>11860 - 15 lbs. approx. (6,8 Kg) 11870 - 19 1/2 lbs. approx. (8,9 Kg)</b>

MODEL	CLUTCH VOLTAGE	CAM	IMPELLER - INSERT	
11860-0004	12	Brass	Neoprene	Brass
11860-0005	12	Brass	Nitrile	Brass
11860-0006	24	Brass	Neoprene	Brass
11860-0007	32	Brass	Neoprene	Brass
11870-0004	12	Brass	Neoprene	Brass
11870-0005	12	Brass	Nitrile	Brass
11870-0006	24	Brass	Neoprene	Brass
11870-0007	32	Brass	Neoprene	Brass

## APPLICATIONS

**MARINE:** Engine cooling, Pumping bilges, Washdowns, Circulating water in bait tanks, Utility dock side pump.  
**INDUSTRIAL:** Circulating and transferring, Velocity-mixing, Pumping machine tool coolants, Return spill, Sump drainage, Chemicals, Pharmaceuticals, Soap, Liquors, Ink, Dyes, Alcohol, Various acids, Tanning Liquors, Glycerine, Brine, etc.  
**FARMING:** Pumping water for stock, Pumping water from shallow wells and cisterns.

**PLUMBING & HOME EMERGENCY USE:** Pumping out flooded basements, Cesspools, Sumps, Water heaters and water closets, Drains and sinks, Draining fishponds and pools.  
**PUBLIC UTILITIES AND MUNICIPALITIES:** Under the hood mounting on service trucks for draining meter boxes, manholes, excavations; For pollution control and watering for dust control.

## OPERATING INSTRUCTIONS

1. **INSTALLATION**-Pump may be mounted in any position. Intake and discharge ports are determined by the direction of shaft rotation (refer to Dimensional Drawing). Before installing, energize clutch and turn the pump shaft in the direction of the operating rotation.
2. **DRIVE-Belt** - Use two 'A' section belts. **NOTE:** Overtight belt load will reduce pump bearing life.
3. **SPEEDS**-100 RPM to the maximum shown in the performance table. Consult the factory for operation at speeds above those shown. For longer pump life, operate at lowest possible speeds.
4. **SELF-PRIMING**-Primes at low or high speeds. For vertical dry suction lift of 10 feet, a minimum of 800 RPM is required. Pump will produce suction lift up to 22 feet when wetted **BE SURE SUCTION LINES ARE AIR TIGHT OR PUMP WILL NOT SELF-PRIME.**
5. **RUNNING DRY**-Unit depends on liquid pumped for lubrication. **DO NOT RUN DRY** for more than 30 seconds. Lack of liquid will burn the impeller.
6. **CAUTION**-Do not pump light fraction petroleum derivatives, solvents, thinners, highly concentrated or organic acids, consult Jabsco "Chemical Resistant Table" F3031 for proper body materials and impeller compounds. If corrosive fluids are handled, pump life will be prolonged if flushed with water after each use or after each work day.
7. **PRESSURES**-Consult Head Capacity Chart for recommended maximum for continuous operation. If pressures exceed those shown, consult the factory.
8. **TEMPERATURES**-Neoprene 45° - 180°F. Nitrile 50° - 180°F.
9. **FREEZING WEATHER**-Drain unit by loosening end cover.
10. **GASKET**-Use a standard pump part. Thicker gasket will reduce priming ability. A thinner gasket will cause the impeller to bind. Standard gasket is .010" thick on the 11860 pump, and .015" thick on the 11870.
11. **SPARE PARTS**-To avoid costly shut downs, keep a Jabsco Service Kit on hand.

## EXPLODED VIEW

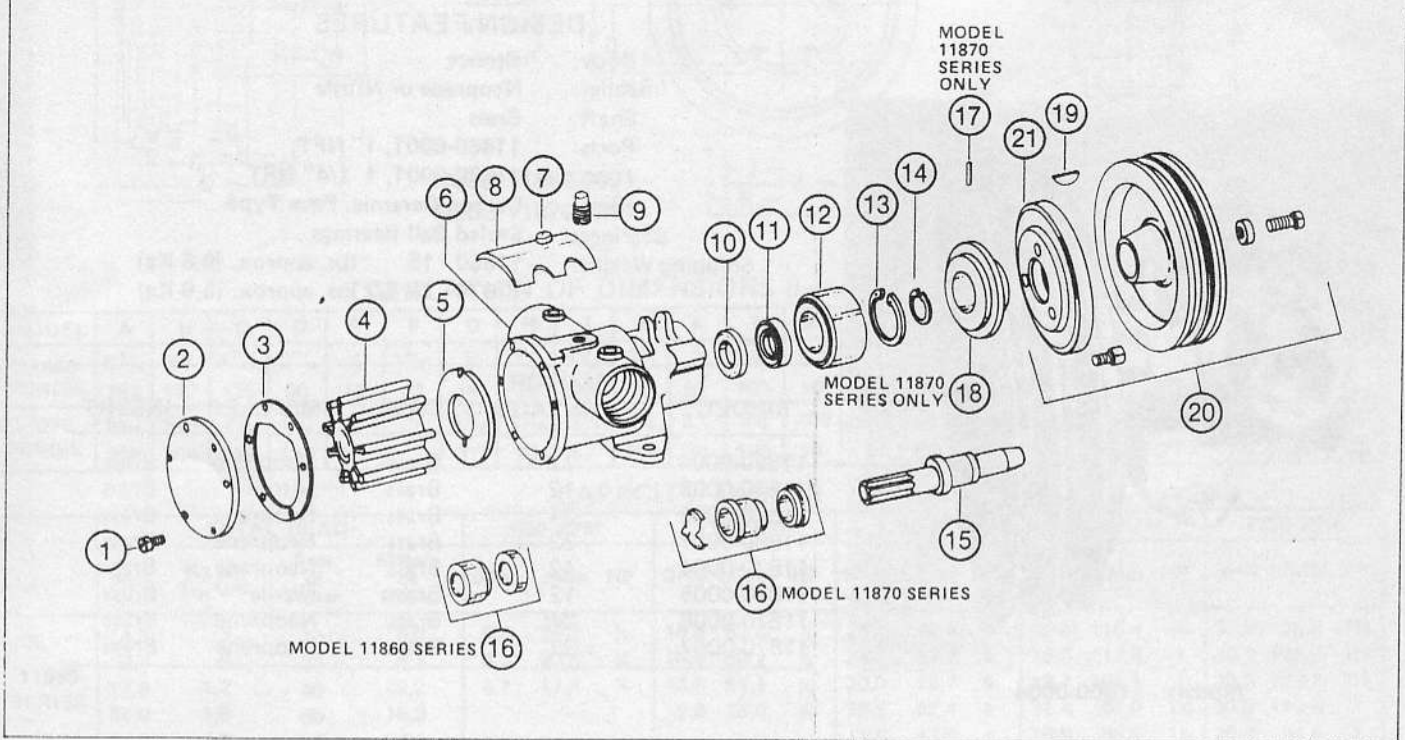

## PARTS LIST

KEY	DESCRIPTION	QTY. REQ.	PART NO.	
			MODEL 11860 SERIES	MODEL 11870 SERIES
1	Screw (End Cover)	6	91003-0010	
	Screw (End Cover)	5		
2	End Cover	1	11831-0000	91005-0040
3	Gasket	1	890-0000	12062-0000
4	Impeller	1	920-0001	816-0000
	Neoprene, Brass		920-0003	836-0001
	Nitrile, Brass			836-0003
5	Wearplate	1	4156-0000	836-0003
6	Body	1	11864-0000	2574-0000
7	Screw (Cam)	1	91004-0090	11874-0000
8	Cam, Brass	1	934-0000	91005-0040
9	Pipe Plug	2	92650-0070	834-0001
10	Slinger	1		92650-0070
11	Seal (Bearing)	1	913-0000	3181-0000
12	Ball Bearing (Pump)	1	92600-0060	817-0000
13	Retaining Ring (Brg to Body)	1	91701-1850	92600-0040
14	Retaining Ring (Brg to Shaft)	1	91700-2470	91700-2460
15	Shaft	1	11867-0000	91700-2450
16	Seal (Shaft)	1	96080-0080	11877-0000
17	Roll Pin (Adaptor)	2		6407-0010
18	Adaptor	1		93100-0160
19	Key (Clutch Drive)	1	91401-0100	11876-0000
20	Clutch Assembly Complete	1	92300-0030	91401-0100
	12V		92300-0061	92300-0030
	24V		92300-0050	92300-0061
	32V		98022-0500	92300-0050
21	Replacement Field Coil		98022-0510	98022-0500
	12V			98022-0510
	32V			
	Service Kit Neoprene Imp.		90118-0001	90062-0001
	Nitrile Imp.		90118-0003	90062-0003

## SERVICE INSTRUCTIONS

**Impeller Replacement:** Remove end cover and gasket. Pull impeller out by grasping hub with pliers. With a rotary motion in the direction the pump will be turning, push the impeller into the impeller bore. A light coating of grease in the impeller bore will protect the impeller during initial dry start up. Install gasket and end cover.

**Shaft Seal Replacement, 11870 Series:** Remove end cover, gasket and impeller, as outlined above. Loosen cam screw several turns. Give cam screw a couple of sharp raps with the handle of the screwdriver to loosen the cam from the impeller bore. Remove the cam screw and cam (clean permatex from cam and impeller bore). Remove wearplate with hooked wire. Remove marcel washer, seal assembly and seal seat assembly from seal bore with hooked wire, taking care not to scratch shaft or seal seat bore. Clean shaft surfaces behind splines and inspect for scratches or wear. Replace if necessary. Before installing new seal parts, clean any oil or grease from carbon and ceramic seal faces. Dip seal seat and gasket assembly in water and press into seal bore with boot first. Dip carbon seal assembly in water and install over shaft, carbon towards ceramic seal seat, until it bottoms firmly against ceramic seat. Slide marcel spring washer over shaft and against the rubber boot (washer) on carbon seal assembly. Replace wearplate, aligning notch with dowel pin in body. Permatex topsurface of cam and cam screw threads and install cam in impeller bore. Snug up but do not tighten cam screw. Replace impeller, gasket and end cover as outlined above. Tighten end cover screws. Tighten cam screw.

**Shaft Seal Replacement, 11860 Series:** Refer to major repair instructions.

**Field Coil Replacement:** Remove drive belts from pulley. Remove center bolt and washer from pulley (it may be necessary to remove end cover to hold impeller from turning, while removing center pulley bolt). Tap pulley with soft mallet to remove from shaft taper. Remove 3 bolts and washers holding field coil to adaptor (11870) or body (11860). Remove and replace field coil, tightening the 3 bolts securely. With drive key in place in shaft, replace pulley assembly. Secure to shaft with center bolt & washer (again it may be necessary to hold the impeller from turning to tighten center bolt). Replace drive belts. Do not over tighten belts. A deflection of 1/2" midway between pulleys is generally considered normal.

**Major Repair:** Remove pump from installation for major repair. Disassembly:

Remove end cover, gasket, impeller, cam and wearplate as outlined in shaft seal replacement, 11870 Series. Remove clutch as outlined in field coil replacement. Model 11870 Series: Use a punch to drive roll pins (key 17) in toward shaft approximately 3/8" (10mm). Remove clutch adaptor from body. Punch roll pins out of adaptor. Model 11860 Series does not have adaptor, clutch is secured directly to body. Remove bearing to body retaining ring. Support bearing end of body on arbor press platten. Press on impeller end of shaft to remove shaft and bearing assembly from body. Use screwdriver to pry inner bearing seal from body. Take care not to scratch or damage body bore.

**11860 Series:** Remove seal seat assembly from shaft. Support impeller end of body on arbor press platten and, using suitable tube, press seal out of seal bore towards impeller end.

**11870 Series:** Remove slinger from drain area. Marcel spring washer and carbon seal assembly will be freed from shaft when shaft is removed from body. Press seal seat assembly from bearing bore end towards impeller bore.

Remove bearing to shaft retaining ring. Support bearing and press on clutch drive end of shaft to remove shaft from bearing.

Assembly: Support inner race of bearing on arbor press platten. Oil shaft, insert drive end of shaft into bearing and press shaft thru bearing until it bottoms firmly against shoulder. Install shaft to bearing retaining ring in groove of shaft. Support impeller bore end of pump on arbor press platten. Lubricate bearing seal with grease and press into bearing seal bore, flush with bearing bore shoulder, with lip facing away from bearing bore. 11870 only: Insert slinger in drain slot, to be picked up by shaft during shaft/bearing assembly. Insert splined end of shaft thru bearing seal (and slinger on Model 11870 Series). Press on outer bearing race to assemble shaft/bearing assembly into body. Bottom bearing firmly against bearing bore shoulder. Install body to bearing retaining ring in groove in body with flat side against bearing. Model 11870 Series only: Install clutch adaptor in bearing bore. If re-using adaptor previously disassembled from pump, line up dowel pin holes during assembly of adaptor to body. If installing new adaptor (which does not have pre-drilled dowel pin holes) insert into bearing bore until it bottoms and use dowel pin holes in body to pilot drill dowel pin holes thru adaptor in two places, 180° apart. Clean any brass

chips from bearing area. Press roll pins into body to secure adaptor. Attach field coil to adaptor (11870 Series) or body (11860 Series) with three round head bolts. Turn body over and support on field coil. 11860 Series: Dip seal seat assembly, consisting of ceramic seal seat and rubber washer, in water and push over shaft, with shiny side of ceramic facing impeller bore, until it bottoms firmly against shaft shoulder. Press on outside edge of seal case with carbon seal face towards ceramic seat to install seal assembly in seal bore. Press flush with bottom of impeller bore.

**11870 Series:** Assemble rubber boot over ceramic seal seat so that shiny surface of seal seat is outwards. Dip assembly in water and insert into seal bore. Press firmly but carefully on seal seat until it bottoms against shoulder of seal bore. Check to see that the seal seat assembly remains in position and does not "pop" back out. A slight twisting motion while pressing will seat it firmly in position. The seal assembly is assembled as follows: 'O' ring is installed in inner bore of ferrule, carbon seal is positioned in ferrule matching dings in ferrule with indentations in carbon seal edge. Small shoulder diameter of carbon (shiny surface) faces outwards. Rubber boot washer is installed on solid face of ferrule. (Note: Some seal assemblies are supplied with a rubber washer cemented to solid face of ferrule.) Dip seal assembly in water and slide assembly over shaft with carbon facing ceramic seal face. Push down over shaft until seal assembly bottoms firmly against ceramic seat. Install marcel spring washer over shaft and push down until it bottoms firmly against rubber boot washer on ferrule. Install wearplate in bottom of impeller bore, locating slot in outside edge of wearplate over dowel pin in body. Permatex surface of cam and cam screw threads and install cam in impeller bore. Edge of cam should be flush with flange face of body. With a rotary motion in the direction the pump will be turning, push the impeller into the impeller bore until it is firmly bottomed. Turn body over to install clutch pulley assembly. Press key into shaft. Position clutch/pulley assembly on shaft aligning key with slot in pulley hub. Secure with bolt and washer. To tighten bolt securely, it may be necessary to hold the impeller to prevent the shaft from turning. Turn pump assembly over. Dip gasket in water, position on pump flange face, install end cover and secure with end cover screws.

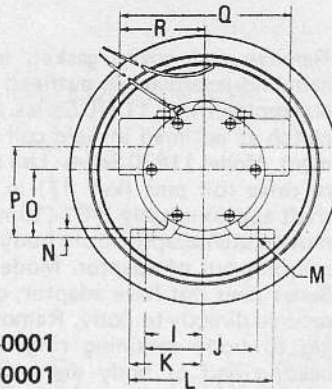
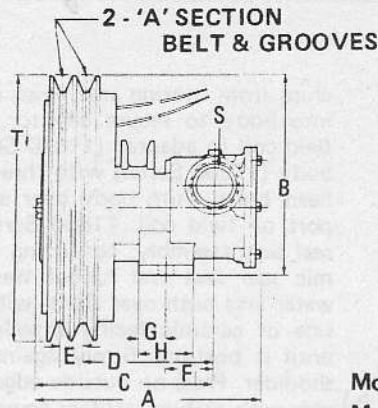

Foot Mounting Details  
For Model 11870-0001

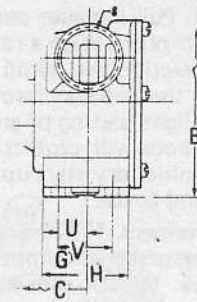

Model 11860-0001  
Model 11870-0001

TABULATION OF DIMENSIONS (Inches and Millimeters)

MODEL	A	B	C	D	E	F	G	H	I	J	K	L	M	N	O	P	Q	R	S	T	U	V
11860 SERIES	6 3/16	5 3/8	4 29/32	3 9/16	5/8	1 1/16	3/4	1 1/2	1 1/16	3 1/8	2	4	.406	1/4	1 7/8	2 1/2	4 3/4	2 3/8	1 1/4-1 1/2	7	-	-
	157	137	125	90	16	33	19	38	40	79	51	102	10	6	48	64	121	60	NPT	178	-	-
11870 SERIES	8 3/16	6 1/4	7 1/16	5 1/4	5/8	-	1 7/16	2 3/16	2 1/4	4 1/2	2 3/4	5 1/2	.406	5/8	2 1/16	3 1/16	5 7/8	2 1 1/16	1 1/4-1 1/2	7	1 3/16	1 1/2
	208	154	179	133	16	-	31	59	57	114	70	140	10	8	65	97	149	75	NPT	178	21	38

CAPACITY TABLES

	TOTAL HEAD				500 RPM			1160 RPM			1750 RPM			2100 RPM		2750 RPM			
	PSI	Kg per Sq. Cm.	Feet of Water	Meters of Water	GPM	L/Min	HP	GPM	L/Min	HP	GPM	L/Min	HP	GPM	L/Min	HP	GPM	L/Min	HP
11860 SERIES	4,3	,3	10	3,0	6.8	25,7	1/4	16.5	62,4	1/2	26.	98,4	3/4	30.5	115,4	1	33.5	126,8	1 1/2
	8,7	,6	20	6,1	6.3	23,8	1/4	15.9	60,2	1/2	24.5	92,7	3/4	29.8	112,8	1	33.3	126,0	1 1/2
	17,3	1,2	40	12,2	4.7	17,8	1/4	13.5	51,1	1/2	20.0	75,7	3/4	26.7	101,1	1	32.3	122,2	1 1/2
	26,0	1,8	60	18,3				9.5	36,0	3/4	16.5	62,4	1	21.4	81,0	1 1/2	30.0	113,5	2
	34,6	2,4	80	24,4							11.5	43,5	1	15.0	56,8	1 1/2	25.0	94,6	2
11870 SERIES	4,3	,3	10	3,0	18	68,1	1/2	41	155,2	1	62	234,7	1 1/2	72	272,5	3			
	8,7	,6	20	6,1	17	64,3	1/2	40	151,0	1	60	227,1	1 1/2	70	264,9	3			
	17,3	1,2	40	12,2	14	53,0	1/2	37	140,0	1 1/2	55	208,2	2	66	249,8	3			
	26,0	1,8	60	18,3				32	121,1	1 1/2	50	189,2	2	60	227,1	3			
	34,6	2,4	80	24,4							44	166,5	3	52	196,8	3			

WIRING

Connect wires as shown for manual on-off operation.

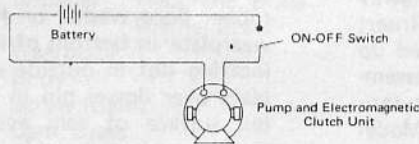

WIRING DIAGRAM

Remote Control and Automatic Engine Driven Bilge Pump

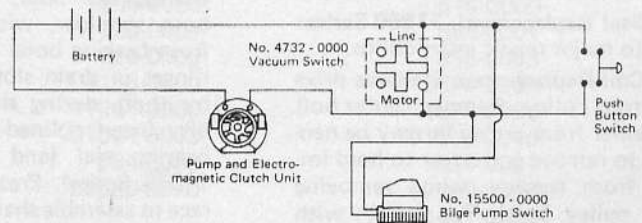

**REMOTE CONTROL** (When Engine Is Running): Install a pushbutton switch at one or more locations. Depress pushbutton for 2 seconds. If there is water in bilge, pump will operate until dry at which time vacuum switch will stop pump. If no water is in bilge, pump will stop when pushbutton is released.

**AUTOMATIC BILGE PUMP** (When Engine Is Running): Install No. 15500-0000 Automatic Bilge Pump Switch where it will energize clutch at maximum high water level in bilge. When water raises switch float, pump will start. Vacuum switch will maintain closed circuit until bilge is pumped dry. Pump will automatically stop, preventing impeller damage.

**ITT JABSCO**

MARC Division

International Telephone and Telegraph Corporation  
1485 Dale Way, Costa Mesa, California 92626

Telephone: (714) 545-8251