



a xylem brand

### SELF-PRIMING PUMPS

#### FEATURES

- Body:** Bronze
- Impeller:** Neoprene or Nitrile
- Shaft:** Stainless Steel
- Shaft Seal:** Mechanical Face Seal or Lip Type
- Wearplate:** Replaceable
- Bearings:** Shielded Ball Bearings
- Ports:** 1" NPT Internal
- Weight:** 5-3/4 lb (2.61 kg)

#### VARIATIONS AVAILABLE

Model No.	Description
777-0001	Neoprene Impeller (Lip Seal)
777-0003	Nitrile Impeller (Lip Seal)
777-9001	Neoprene Impeller (Face Seal)
777-9003	Nitrile Impeller (Face Seal)
777-9051	Half Thickness Cam (Face Seal)

#### APPLICATIONS

**MARINE** – Pump bilge, Washdowns, Circulating water in bait tanks, Utility dock-side pump, Engine cooling.

**INDUSTRIAL** – Circulating and transferring, Velocity-mixing, Pumping machine tool coolants, Return spill, Sump drainage, Chemicals, Pharmaceuticals, Soap, Liquors, Ink, Dyes, Alcohol, Dilute acids, Tanning Liquors, Glycerine, Brine, etc.

**FARMING** – Pumping water for stock, Pumping water from shallow wells and cisterns, Pumping liquid ballast into tractor tires.

**PLUMBING AND HOME EMERGENCY USE** – Pumping out flooded basements, Cesspools, Sumps, Water heaters and water closets, Drains and sinks, Draining fishponds and pools.

#### OPERATING INSTRUCTIONS

1. Installation – Pump may be mounted in any position. The rotation of the pump shaft determines the location of the pump's intake and discharge ports. (Refer to dimensional drawing.) Pump is normally assembled at factory for clockwise rotation (looking



Model 777-Series

at end cover). If counter clockwise rotation is desired, follow steps 1 and 2 of disassembly and step 11 of assembly instructions to change direction of impeller blade deflection under cam.

- 2. Drive – Belt or Direct with flexible coupling.  
Belt – Overtightened belt load will reduce pump bearing life.

Direct – Clearance should be left between drive shaft and pump shaft when installing coupling. Always mount and align pump and drive shaft before tightening the coupling set screw.

**NOTICE:** If pulley or coupling must be pressed on shaft, remove end cover and impeller to support shaft from impeller end during press operation. Do not hammer pulley or coupling on shaft; this may damage bearings or seal.

- 3. Speeds – 100 RPM to the maximum shown in the performance table. Consult the factory for operation at speeds above those shown. For longer pump life, operate at lowest possible speeds.
- 4. Self-Priming – Primes at low or high speeds. For vertical dry suction lift of 10 feet, a minimum of 800 RPM is required. Pump will produce suction lift up to 22 feet when wetted. **BE SURE SUCTION LINES ARE AIRTIGHT OR PUMP WILL NOT SELF-PRIME.**
- 5. Running Dry – Unit depends on liquid pumped for lubrication. **DO NOT RUN DRY** for more than 30 seconds. Lack of liquid will damage the impeller.
- 6. Notice – Do not pump light fraction petroleum derivatives, solvents, thinners, highly concentrated or organic acids. Damage to pump may result.

Consult Jabsco Chemical Resistance Table (available upon request from the factory) for proper body materials and impeller compounds. If corrosive fluids are handled, pump life will be prolonged if pump is flushed with water after each use or after each work day.

7. Pressures – Consult Head Capacity Table for recommended maximum for continuous operation. If pressures exceed those shown, consult the factory.
8. Temperatures – Neoprene 45°-180°F (7-82°C). Nitrile 50°-180°F (10°-82°C).
9. Freezing Weather – Drain unit by loosening end cover. The following anti-freeze compounds can be used without any adverse effects to the neoprene impeller: Atlas “Permaguard”, DuPont “Zerex” and “Telar”, Dow Chemical “Dowguard” and Olin Mathison “Pyro” Permanent. Most Methyl alcohol (methanol) based anti-freeze can be used.

**DO NOT USE PETROLEUM BASED ANTI-FREEZE COMPOUNDS OR RUST INHIBITORS.**

10. Gasket – Use a standard pump part. Thicker gasket will reduce priming ability. A thinner gasket will cause the impeller to bind. Standard gasket is 0.010” thick.
11. Spare Parts – To avoid costly shutdowns, keep a

	<b>WARNING</b> Chemical hazard. Pumps which have handled corrosive, caustic or toxic fluids should be drained and completely flushed prior to servicing. Failure to do so can cause injury.
---	---

JABSCO Service Kit on hand.

## SERVICE INSTRUCTIONS

### DISASSEMBLY

1. Remove end cover screws, end cover and gasket.
2. Grasp hub of impeller with water pump pliers and withdraw from body.
3. Remove cam screw and cam; clean sealant from cam and body bore.
4. Remove wearplate.
5. Insert screwdriver between OD of outer bearing seal and bearing bore and pry seal out.
6. Remove bearing to body retaining ring.
7. Press on impeller drive end of shaft to remove shaft and bearing assembly.
8. Using extreme care not to mar body bore, insert screwdriver between OD of inner bearing seal and bearing seal bore and pry out seal.
9. **Lip seal versions:** Press seal out of body towards impeller bore.

**Face seal versions:** Remove ceramic seal seat

and seat gasket from shaft. Press carbon seal seat out of body towards impeller bore.

10. Remove bearing shaft retaining ring.
11. Support bearing inner race, press on drive end of shaft to remove shaft from bearing. Do not attempt to remove bronze bushing which is pinned to shaft.
12. Inspect all parts for wear or damage and replace where necessary.

### ASSEMBLY

1. Lubricate inner bearing seal lip with grease and press into body bearing seal bore with lip facing away from bearing bore.
2. Press shaft into bearing, using care to support inner race of bearing.
3. Install bearing to shaft retaining ring with flat side toward bearing.
4. Position slinger in body drain area. Insert splined end of shaft through bearing bore and guide slinger over shaft until bearing contacts body. Align slinger with raised shoulder on shaft as the shaft/bearing assembly is pressed the last 1/4” into the bearing bore.
5. Pressing on bearing outer race, install bearing into bore.
6. Install bearing to body retaining ring in body groove with flat side toward bearing.
7. Lubricate outer bearing seal lip with grease and press into bearing bore until it is flush with the body.
8. **Lip seal versions:** Lubricate OD and lip of seal, then push into place, using care not to damage or cut seal lip. (Lip faces impeller bore.)  
**Face seal versions:** Lubricate rubber grommet in ceramic seal seat with water and install on shaft, grommet toward bearing. Install seal (carbon toward ceramic seat) in seal bore and press flush with bottom of impeller bore.
9. Install wearplate in body bore, aligning slot in wearplate with dowel pin in body.
10. Apply a thin coat of sealant to cam screw threads and top side of cam and install in body with cam screw.
11. Lubricate impeller bore and end surfaces of impeller with light coat of water pump grease and start impeller into bore with a rotary motion until splines engage, then push into bore.
12. Install gasket and end cover and secure with end cover screws.

## EXPLODED VIEW

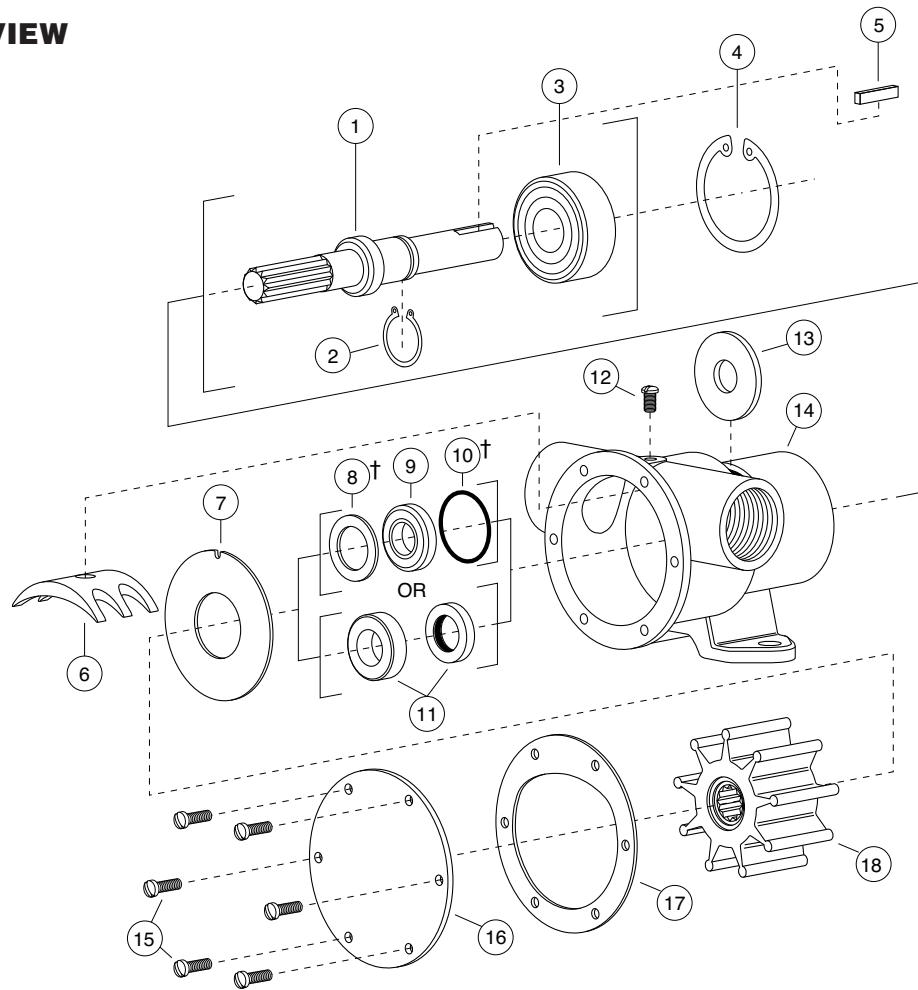

## PARTS LIST

Key	Description	Model 777-0001	Model 777-0003	Model 777-9001	Model 7777-9003	Model 7777-9051
1	Shaft	6718-0000	6718-0000	6718-0000	6718-0000	6718-0000
2	Retaining Ring (Brg. to Shaft)	18713-0000	18713-0000	18713-0000	18713-0000	18713-0000
3	Ball Bearing	92600-0060	92600-0060	92600-0060	92600-0060	92600-0060
4	Retaining Ring (Brg. to Body)	18724-0000	18724-0000	18724-0000	18724-0000	18724-0000
5	Key	9215-0000	9215-0000	9215-0000	9215-0000	9215-0000
6	Cam (Brass)	934-0000	934-0000	934-0000	934-0000	2431-0000
7	Wearplate	4156-0000	4156-0000	4156-0000	4156-0000	4156-0000
8	Seal Spacer†	3166-0000	3166-0000	—	—	—
9	Seal (Lip)* **	92700-0060	92700-0060	—	—	—
10	O-Ring* †	92000-0210	92000-0210	—	—	—
11	Seal (Face)* **	—	—	96080-0080	96080-0080	96080-0080
12	Screw (Cam)	91004-0090	91004-0090	91004-0090	91004-0090	91004-0090
13	Slinger, used with Lip Seal only	3181-0000	3181-0000	3181-0000	3181-0000	3181-0000
14	Body	798-0020	798-0020	798-0020	798-0020	798-0020
15	Screw (End Cover)	91003-0010	91003-0010	91003-0010	91003-0010	91003-0010
16	End Cover	11831-0000	11831-0000	11831-0000	11831-0000	11831-0000
17	Gasket*	890-0000	890-0000	890-0000	890-0000	2432-0000
18	Impeller* - Neoprene, Brass Insert	17937-0001	—	17937-0001	—	17937-0001
	Nitrile, Brass Insert	—	920-0003	—	920-0003	—
	Service Kit (Not Shown)	90010-0001	90010-0003	90118-0001	90118-0003	90118-0001

\* Parts supplied in Service Kit.

† Used for models prior to August 1, 1964.

NOTE: 5915-0001, High Pressure Neoprene Impeller available; contact factory for application recommendations.

\*\* When replacing shaft seal, the outer bearing seal is often distorted beyond serviceability and should be replaced.

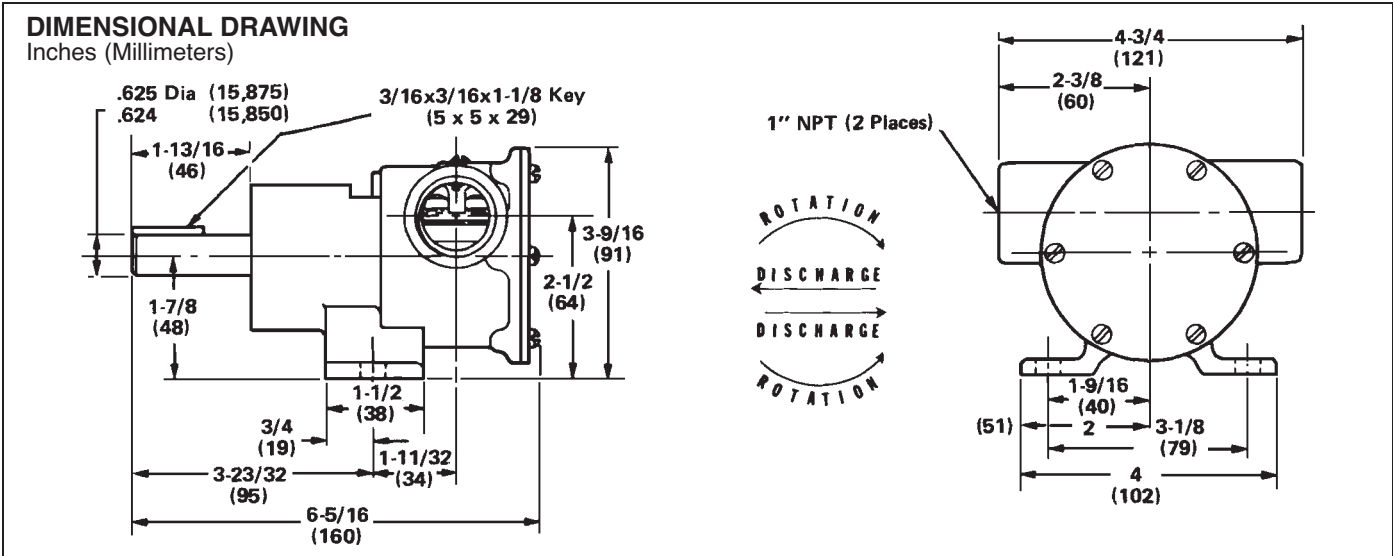

**PERFORMANCE TABLES**

**Model 777-9001**

Total Head		500 RPM		1160 RPM		1750 RPM		2100 RPM		2750 RPM		3000 RPM	
psi (kg/sq cm)	Feet of Water (Meters)	GPM (L/Min)	HP	GPM (L/Min)	HP	GPM (L/Min)	HP	GPM (L/Min)	HP	GPM (L/Min)	HP	GPM (L/Min)	HP
4.3 (0.3)	10 (3.0)	6.0 (22.7)	1/4	14.7 (55.6)	1/3	23.3 (88.2)	3/4	27.9 (105.6)	3/4	33.8 (127.8)	1-1/2	35 (132.5)	1-1/2
8.7 (0.6)	20 (6.1)	5.6 (21.2)	1/4	13.8 (51.9)	1/2	22.0 (8.3)	3/4	26.8 (101.3)	1-1/2	32.9 (124.5)	1-1/2	34.3 (129.8)	1-1/2
17.3 (1.2)	40 (12.2)	4.6 (17.4)	1/4	11.5 (43.5)	1/2	19.3 (73.1)	3/4	23.9 (90.5)	1-1/2	30.5 (115.5)	1-1/2	32.5 (123.0)	1-1/2
26.0 (1.8)	60 (18.3)	—	—	7.8 (29.5)	3/4	15.5 (58.7)	1	19.2 (72.5)	1-1/2	26.1 (98.6)	2	29.3 (110.9)	2
34.6 (2.4)	80 (24.4)	—	—	—	—	10.0 (37.9)	1	13.2 (49.8)	1-1/2	19.9 (75.3)	2	23.5 (89.1)	2

**Model 777-9051**

Total Head		500 RPM		1160 RPM		1750 RPM		2100 RPM		2750		3000 RPM	
psi (kg/sq cm)	Feet of Water (Meters)	GPM (L/Min)	HP	GPM (L/Min)	HP	GPM (L/Min)	HP	GPM (L/Min)	HP	GPM (L/Min)	HP	GPM (L/Min)	HP
4.3 (0.3)	10 (3.0)	4.0 (15.1)	1/4	8.7 (32.9)	1/4	13.6 (51.5)	1/2	16.7 (63.2)	3/4	22.3 (84.4)	1	34.0 (90.8)	1
8.7 (0.6)	20 (6.1)	3.4 (12.9)	1/4	8.0 (30.3)	1/3	12.8 (48.4)	1/2	15.8 (59.8)	3/4	21.2 (79.9)	1	23.2 (87.8)	1-1/2
17.3 (1.2)	40 (12.2)	2.0 (7.6)	1/4	5.8 (22.0)	1/3	10.4 (39.4)	3/4	13.5 (51.1)	3/4	18.5 (70.0)	1	22.0 (83.3)	1-1/2
26.0 (1.8)	60 (18.3)	—	—	—	—	7.0 (26.5)	3/4	10.0 (37.9)	1	14.5 (54.9)	1-1/2	16.0 (60.6)	1-1/2

NOTE: Table shows approximate head-flow for new pump, with a neoprene impeller, in U.S. gallons per minute and liters per minute. For a nitrile impeller, reduce values by 10%. Progressively longer life may be expected as operating pressures and speeds are reduced. Factory application engineering assistance is recommended for shaded area. High starting torque motors are required. Pump starting torque in dry condition (no fluid in pump body) is 45.7 inch-pounds and in wet condition (fluid in pump body) is 39.0 inch-pounds.

THE PRODUCTS DESCRIBED HEREIN ARE SUBJECT TO THE JABSCO ONE YEAR LIMITED WARRANTY, WHICH IS AVAILABLE FOR YOUR INSPECTION UPON REQUEST.

[www.xylemflowcontrol.com](http://www.xylemflowcontrol.com)

Jabscos, 100 Cummings Center, Ste. 535-N, Beverly, MA 01915  
 Tel: +1 978 281 0440 Fax: +1 978 283 2619

Jabscos, Bingley Road, Hoddesdon, Hertfordshire, EN11 0BU  
 Tel: +44 (0) 1992 450 145 Fax: +44 (0) 1992 467 132

NHK Jabscos Co Ltd, 3-21-10, Shin - Yokohama Kohoku-ku, Yokohama 222  
 Tel: +81 (0) 45 475 8906 Fax: +81 (0) 45 475 8908

Jabscos GmbH, Oststraße 28, 22844 Norderstedt  
 Tel: +49 (0) 40 53 53 73 0 Fax: +49 (0) 49 53 53 73 11

Jabscos Italia, s.r.l., Via Tommaseo, 6, 20059 Vimercate, Milano  
 Tel: +39 039 685 2323 Fax: +39 039 666 307

USA

UK

JAPAN

GERMANY

ITALY



a xylem brand