



Models 63020, 63022, 63042

## 6" REMOTE CONTROL SEARCHLIGHT

### FEATURES

- Complete drive unit contained in light head.
- Single lever or touch-pad control for vertical and horizontal light movement.
- Two speed light movement.
- Auto-sweep mode cycles light side-to-side automatically.
- Light will transmit an "SOS" distress signal automatically.
- Designed for salt water with chrome brass housing and base.
- Control is water resistant with plug-in connections.
- Two station operation optional with use of dual station kit.
- Two types of light output:
  - Spot/flood sealed beam bulb, 200,000/50,000 candlepower.
  - Spot beam high intensity discharge bulb, 600,000 candlepower.

Model	Voltage	Beam	Base
63020-0012	12/24	Spot/Flood	Chrome Zinc-Short
63022-0012	12/24	Spot/Flood	Chrome Brass-Tall
63022-1224	12/24	Spot/Flood	Chrome Brass-Tall
63042-0012	12	HID Spot	Chrome Brass-Tall
63042-0024	24	HID Spot	Chrome Brass-Tall

Lights include control and 15' cable from control to light. Extension cables can be used to increase cable length.

### ACCESSORIES

Extension Cables With Plugs		Bulk Cable No Plugs	
Part Number	Length	Part Number	Length
64042-1011	10'	64043-0100	100'
64042-1007	15'	64043-0250	250'
64042-1008	25'	64043-0500	500'
64042-1009*	50'	64043-1000	1000'

\* This is heavy gauge wire required for runs of 50'.

Dual Station Kit #64044-0000 Includes control, Y-adaptor and 15' cable. Use for boats with two control locations.

Cable Plug Kit #64045-0000 Includes male/female plugs with 2' cable for connecting to bulk cable.



63020



63022 AND 63042

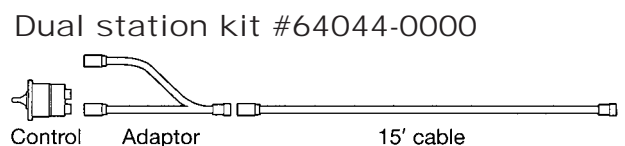
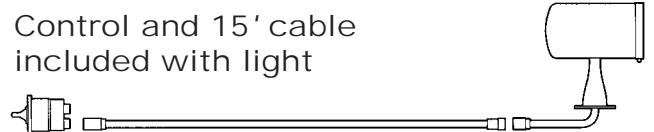

Models 63020, 63022, 63042

## LIGHT MOUNTING

Light should be mounted forward of the operator's position on the boat. Use the base mounting gasket as a template to drill mounting holes. A 7/8" (20mm) hole is required to pass the cable plug. The short base has a line on the mounting flange to indicate the forward positioning of the light. The cable plug can be pushed below the mounting into the hole or pushed into the base of the tall base model lights. The cable is routed through the boat to the control location.

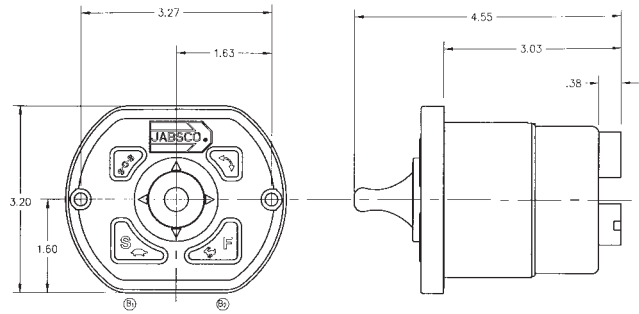

## CONTROL MOUNTING

1. Select a location near the helm position to mount the control. Check under the mounting area to assure there is adequate clearance for the control.
2. Cut 2-3/4" (70mm) diameter hole for the control and drill two holes for the mounting screws.
3. Power to control must be controlled by the boat running light switch. The searchlight control has LED illumination that will go on with the boat running lights. The searchlight can only be used with the running lights on. The running light circuit must be capable of carrying the following amperage load in addition to the running lights and have a fuse or circuit breaker of appropriate size:

Bulb Type	Voltage	Amperage
Spot/Flood Sealed Beam	12	15
Spot/Flood Sealed Beam	24	15
High Intensity Discharge	12	15
High Intensity Discharge	24	20

4. Connect the RED control power lead to the switched side of the running light circuit. Connect the BLACK control power lead to a battery negative source. DO NOT connect in reverse polarity, as control damage will result. Use 12–14 gauge wire to extend power leads if necessary.
5. Bring power leads and light cable through hole and plug into back of control.
6. To eliminate electrical interference produced by other electronic components on the boat that might affect the searchlight control, route the searchlight control cable to the light away from other components such as radios, GPS receivers and other navigation units.
7. Insert control with attached cables into hole and fasten with screws. A non-adhesive sealing compound should be used under the control mounting flange.
8. For joy-stick type of control, thread black lever into center hole. For touch-pad operation, insert black cap into threaded hole.

## LIGHT OPERATION

**IMPORTANT** — Do not shine the searchlight in any manner that will impair the vision of other boat operators.

The running light switch for the boat must be "on" for searchlight to operate. With the running light switch "on", the searchlight control will be illuminated.

**SPOT/SLOW** — Press once to select slow light movement speed and, on spot/flood type lights, to select spot beam. Press again to turn light off.

**FLOOD/FAST** — Press once to select fast light movement speed and, on spot/flood type lights, to select flood beam. On lights with spot beam only, this button selects the fast speed only. Press again to turn light off.

**DIRECTIONAL MOVEMENT** — The center lever is moved left, right, fore and aft to move light head. If desired, the center lever can be unscrewed (counter-clockwise) and the black cap (supplied) can be pressed into the center hole. The light movement is then controlled by touching one of the four arrows.

**AUTO SWEEP** — With the light on, pushing this button will sweep the light in about a 90 degree arc automatically. This is useful in narrow canals and channels, freeing both hands for boat control. Press again to stop auto sweep.

**SOS/DISTRESS** — Press and hold for about five seconds to automatically flash "SOS" in International Morse Code. The light will sweep horizontally while flashing the SOS. Press again to stop the SOS flashing.

**IMPORTANT** — Do not allow anyone to "playfully" transmit the SOS signal! The SOS signal will not be transmitted with the boat's running lights "off".

## CIRCUIT PROTECTION

The searchlight control has built-in circuit breaker protection for the searchlight. The breaker can be reset by turning the light on then off with the running lights on.

On 24VDC lights, do not operate the light at less than 18 volts. Turn off the light before recharging battery.

## DUAL STATION CONTROL (OPTIONAL)

The optional Dual Station Control Kit #64044-0000 is used when an additional searchlight control location is desired.

1. Install control in the dual station kit as covered in the "Control Mounting" section of these instructions.
2. Using the 15' cable and Y adaptor included in the dual station kit, connect the cable into the light control cable.

Optional extension cables may be used where necessary to fit the application. Also, the 3 conductor cable may be cut and spliced together if too long.

EXPLODED VIEW

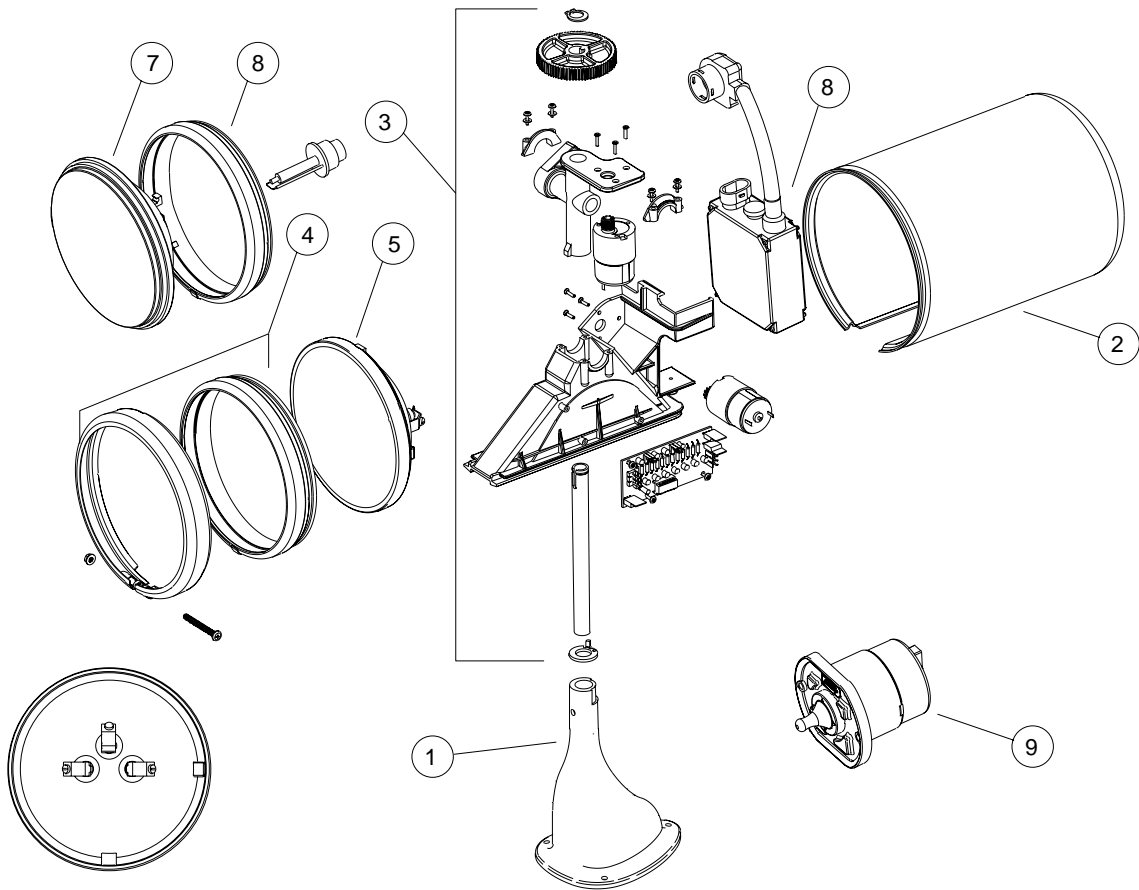

Key No.	Part Description	63020-Series		63022-Series		63042-Series	
		Part No.	Qty.	Part No.	Qty.	Part No.	Qty.
1	Base (includes gasket and set screws) Tall Brass Chrome Short Zinc Chrome	---	-	64046-0000	1	64046-0000	1
		63130-0000	1	---	-	---	-
2	Housing	64046-0001	1	64046-0001	1	64046-0001	1
3	Motor/Support Assembly 12VDC and 24VDC 12 VDC for HID 24 VDC for HID	64046-0002	1	64046-0002	1	---	-
		---	-	---	-	64046-0003	1
		---	-	---	-	64046-0004	1
4	Bulb Retaining Ring, Screw and Nut	64046-0005	1	64046-0005	1	64046-0005	1
5	Spot/Flood Bulb and Seal 12VDC and 24VDC	64046-0006	1	64046-0006	1	---	-
6	HID Bulb 12 VDC 24 VDC	---	-	---	-	64046-0007	1
		---	-	---	-	64046-0007	1
7	HID Lens, Reflector and Seal	---	-	---	-	64046-0009	1
8	HID Ballast 12 VDC for HID 24 VDC for HID	---	-	---	-	64046-0010	1
		---	-	---	-	64046-0011	1
9	Control	43690-1000	1	43690-1000	1	43690-1000	1

## 63020 SERIES

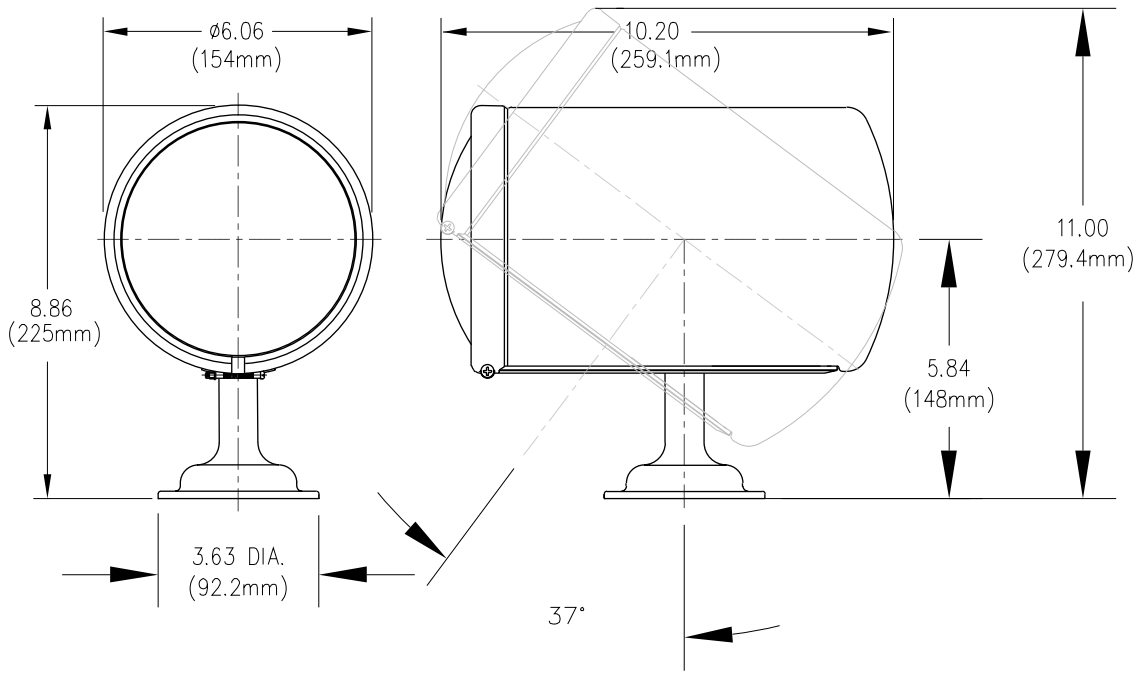

## 63022 AND 63042 SERIES

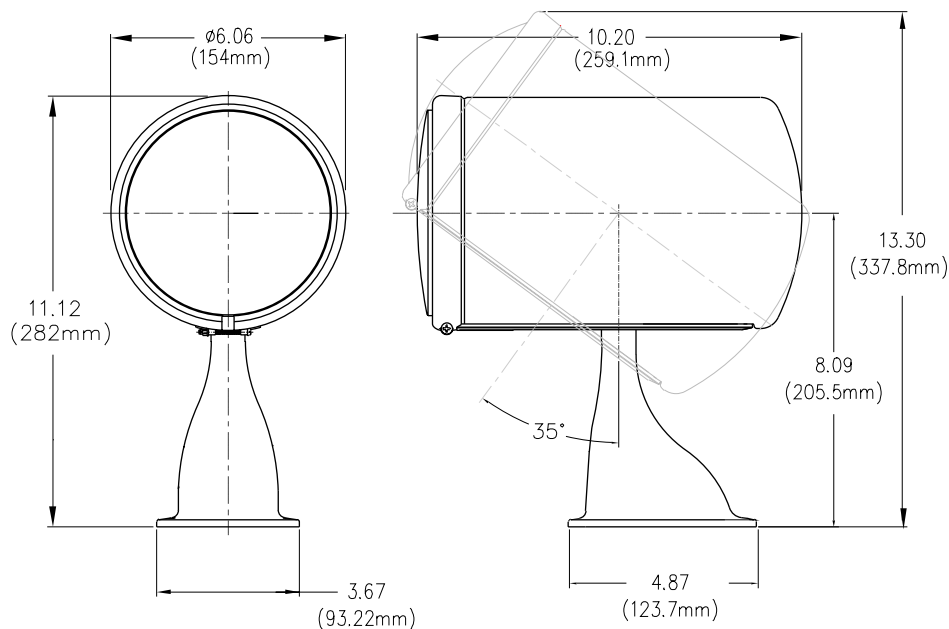

# Jabsco



**ITT Industries**  
*Engineered for life*

THE PRODUCTS DESCRIBED HEREIN ARE SUBJECT TO THE JABSCO ONE YEAR LIMITED WARRANTY, WHICH IS AVAILABLE FOR YOUR INSPECTION UPON REQUEST.

U.S.A.  
Jabsco  
Cape Ann Industrial Park  
Gloucester, MA 01930  
Tel: 978.281.0440  
Fax: 978.283.2619

UNITED KINGDOM  
Jabsco  
Bingley Road, Hoddesdon  
Hertfordshire EN11 OBU  
Tel: +44 (0) 1992 450145  
Fax: +44 (0) 1992 467132

CANADA  
Fluid Products Canada  
55 Royal Road  
Guelph, Ontario N1H 1T1  
Tel: (519) 821.1900  
Fax: (519) 821.2569

JAPAN  
NHK Jabsco Company Ltd.  
3-21-10, Shin-Yokohama  
Kohoku-Ku, Yokohama, 222  
Tel: 045.475.8906  
Fax: 045.475.8908

GERMANY  
Jabsco GmbH  
Oststrasse 28  
22840 Norderstedt  
Tel: +49-40-53 53 73 -0  
Fax: +49-40-53 53 73 -11