



a xylem brand

## REMOTE CONTROL SEARCHLIGHT

### FEATURES

- Two High Output Sealed Beam Lamps
- Sleek Design
- Rugged Construction
- Full 360° Rotation
- Remote Control and 25 ft. Cable Included
- Tough Polyurethane Finish

### SPECIFICATIONS

**Voltage:** 12 Vdc and 24 Vdc

**Elevation Angle**



**Model 60010-2 Series**

**(degrees):** Up: 30°, Down: 30°

**Housing Material:** Thermoset Plastic

**Candle Power:** 200,000

Model Number	Voltage	Amps	Bulb Type	Weight lb (kg)	Standard Carton
60010-2012	12 Vdc	8	SPOT/SPOT	11 (5)	1
60010-2024	24 Vdc	4	SPOT/SPOT	11 (5)	1

## INSTALLATION INSTRUCTIONS

### LIGHT MOUNTING

Select a location for the light which will allow clear beam projection forward and as far aft as possible. Searchlight base should be mounted on a level, flat surface. A mounting block between the searchlight base and mounting surface can be used. The block should be contoured to fit the deck so the searchlight base is level. See mounting template attached for plug and cable required clearance.

1. Mount light with front of base towards the direction of most intended use (front of circular base is marked "front") with gasket under light base.
2. Feed wire through hole and secure light in place. NOTE: cable connectors are provided for easy wiring connections.

Mounting hardware is provided:

- 4 1/4-20 x 2" (6.5mm x 50mm) bolts
- 4 lockwashers

4 flatwashers

### CONTROL MOUNTING

Choose a location for the main control near the helm which will allow convenient operation. Control may be mounted on vertical, horizontal, or inclined panel.

1. Route powerleads (supplied by customer) from the voltage source to control. NOTE: Wiring must be 16 gauge with a maximum run of 15 feet.
2. Crimp terminals (supplied) onto the power leads, NOTE: larger terminal is crimped to positive lead, smaller terminal is crimped to negative lead.
3. Insert wiring cable thru back of hole and plug into control.
4. Use bedding compound or sealant to waterproof control.
5. Secure control with self-tapping screws provided.

## OPTIONAL SECONDARY CONTROL MOUNTING

If an additional control station is desired use control kit numbers 43670-0004 (12 volt) or 18753-0335 (24 volt). Mount secondary control in same manner as main control. Mount station selector panel near the main control (flybridge or lower).

1. Cut a 2" x 1-3/8" (51mm x 35mm) opening for station selector panel within a 1 foot radius of the control.
2. Route secondary control cable from station selector panel to secondary control location (cable acquired separately - see cable listing).
3. Insert station selector panel thru mounting hole and attach connectors to mating connectors from control and search-light. The connector marked "flybridge" to go to flybridge control and the connector marked "lower" to lower control. The connector to the nearest control can be plugged directly into the control. See diagram.
4. Use bedding compound or sealant to waterproof station selector panel mounting.
5. Secure panel with self-tapping screws provided.

## CIRCUIT PROTECTION

Two (2) automotive blade type fuses are included in the control. One (10 amp) protects the bulb circuit, the other (3 amp) protects the motor circuit. In the event that it should be necessary to replace a fuse simply pull off the protective cover and slide the fuse out.



## TROUBLESHOOTING

All lights are thoroughly inspected before shipping and are warranted to operate within specifications. If light does not operate

### PROBLEM

Control lever works in reverse in all directions.

Light moves in only three of the possible four directions.

Dim light (low voltage)

Bulb operates - no light movement  
or

Light moves - bulb does not operate.

### SOLUTION

See wiring instructions.

- A. Check connectors.
- B. Replace control.
- C. If problem persists, return light & control for service.

- A. Check voltage at power source.
- B. Refer to cable listing for proper wire gage and length.

- A. Check fuses on front of control.
- B. Check bulb.

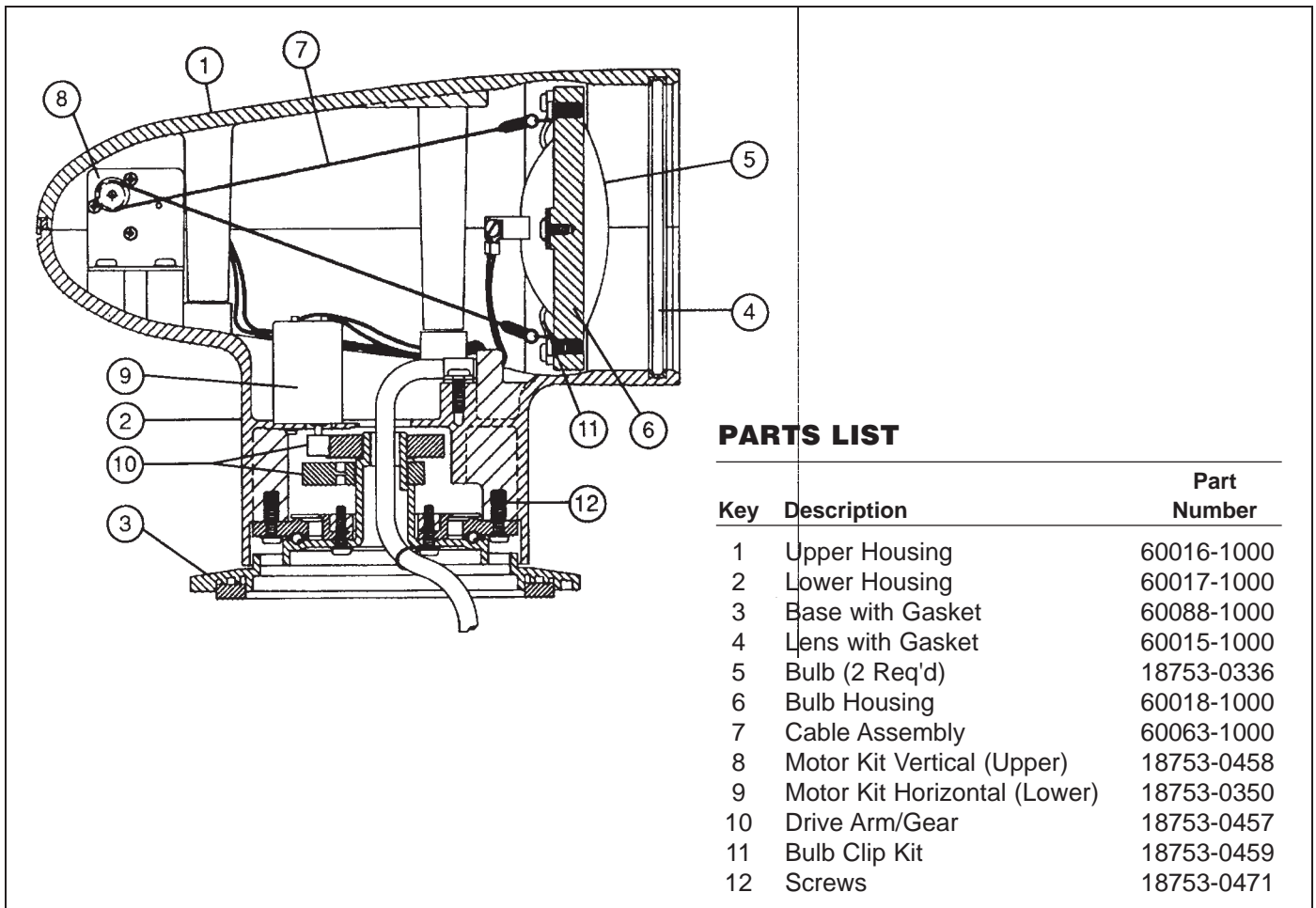

**PARTS LIST**

Key	Description	Part Number
1	Upper Housing	60016-1000
2	Lower Housing	60017-1000
3	Base with Gasket	60088-1000
4	Lens with Gasket	60015-1000
5	Bulb (2 Req'd)	18753-0336
6	Bulb Housing	60018-1000
7	Cable Assembly	60063-1000
8	Motor Kit Vertical (Upper)	18753-0458
9	Motor Kit Horizontal (Lower)	18753-0350
10	Drive Arm/Gear	18753-0457
11	Bulb Clip Kit	18753-0459
12	Screws	18753-0471

**DUAL STATION KIT**

Model		Kit
60010-0012	12V	43670-0004
60010-0024	24V	18753-0335

**BULB REPLACEMENT REFERENCE**

Model No.		Bulb
60010-0012	12V	18753-0336
60010-0024	24V	18753-0336

\*NOTE: A 25' wiring cable is provided with each light.

Additional lengths may be ordered. Dual station kits require additional cables (see wiring diagram). Order cable length required from table below.

**ACCESSORY CABLE LISTING**

Part Number	Description
43990-0013	10' Cable Assembly
43990-0014	15' Cable Assembly
43990-0015	25' Cable Assembly
43990-0016	35' Cable Assembly
67294-0000	50' Bulk Cable

NOTE: Secure cable with nylon clips or equivalent.

Protect installation at points of stress, and leave adequate slack where cable must be flexible.

**BULB REPLACEMENT**

1. Disconnect wires, noting location on bulb.
2. Loosen the screws on the bulb retaining clips.
3. Remove bulb from bulb housing.
4. Install new bulb making certain that the boss on the bulb edge is in the H shaped locating clip in the center of the bulb housing.
5. Tighten screws on the bulb clips.
6. Reconnect wires in previous positions.

**12 VOLT SPOT/SPOT**

**24 VOLT SPOT/SPOT**

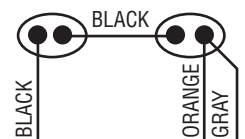
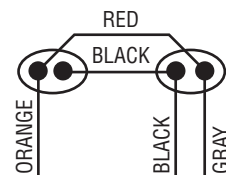

## DIMENSIONAL DRAWING

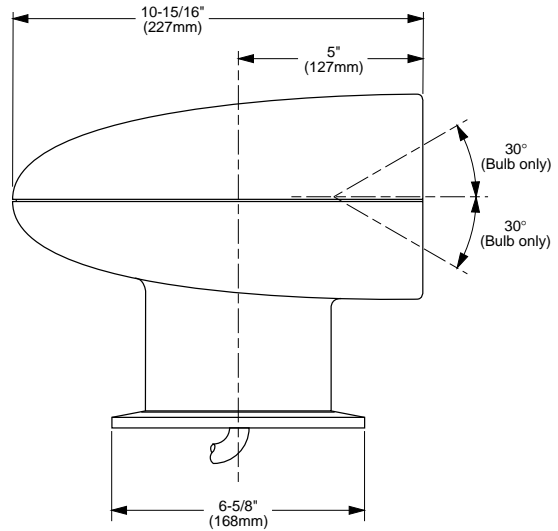
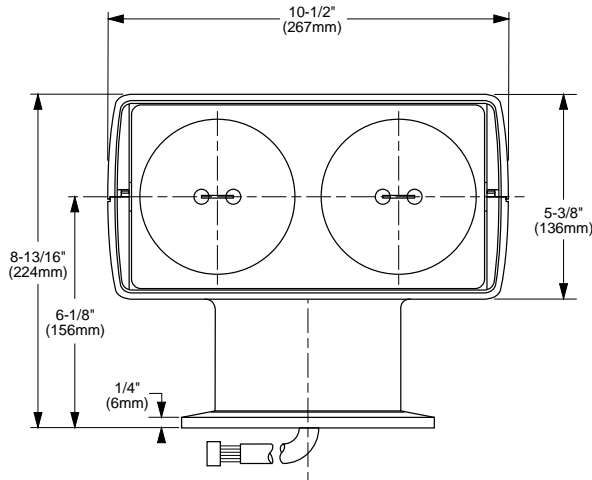

## REMOTE CONTROL MOUNTING DIMENSIONS

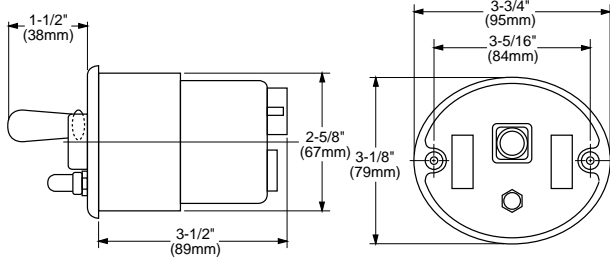

## STATION SELECTOR PANEL DRAWING

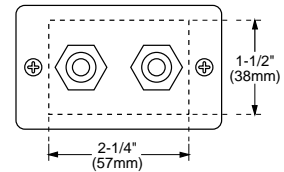

## WIRING DIAGRAM SINGLE CONTROL

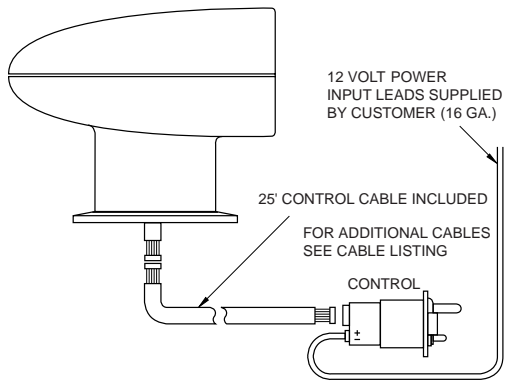

## WIRING DIAGRAM, OPTIONAL SECONDARY REMOTE CONTROL

SECONDARY CONTROL  
KIT NO. 43670-0004 12V; 18753-0335 24V

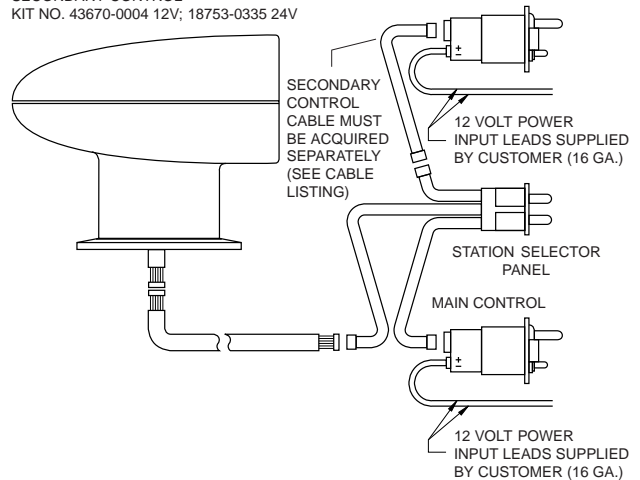

THE PRODUCTS DESCRIBED HEREIN ARE SUBJECT TO THE JABSCO ONE YEAR LIMITED WARRANTY, WHICH IS AVAILABLE FOR YOUR INSPECTION UPON REQUEST.

[www.xylemflowcontrol.com](http://www.xylemflowcontrol.com)

Jabco, 100 Cummings Center, Ste. 535-N, Beverly, MA 01915  
Tel: +1 978 281 0440 Fax: +1 978 283 2619

Jabco, Bingley Road, Hoddesdon, Hertfordshire, EN11 0BU  
Tel: +44 (0) 1992 450 145 Fax: +44 (0) 1992 467 132

NHK Jabco Co Ltd, 3-21-10, Shin - Yokohama Kohoku-ku, Yokohama 222  
Tel: +81 (0) 45 475 8906 Fax: +81 (0) 45 475 8908

Jabco GmbH, Oststraße 28, 22844 Norderstedt  
Tel: +49 (0) 40 53 53 73 0 Fax: +49 (0) 49 53 53 73 11

Jabco Italia, s.r.l., Via Tommaseo, 6, 20059 Vimercate, Milano  
Tel: +39 039 685 2323 Fax: +39 039 666 307

USA

UK

JAPAN

GERMANY

ITALY



a xylem brand

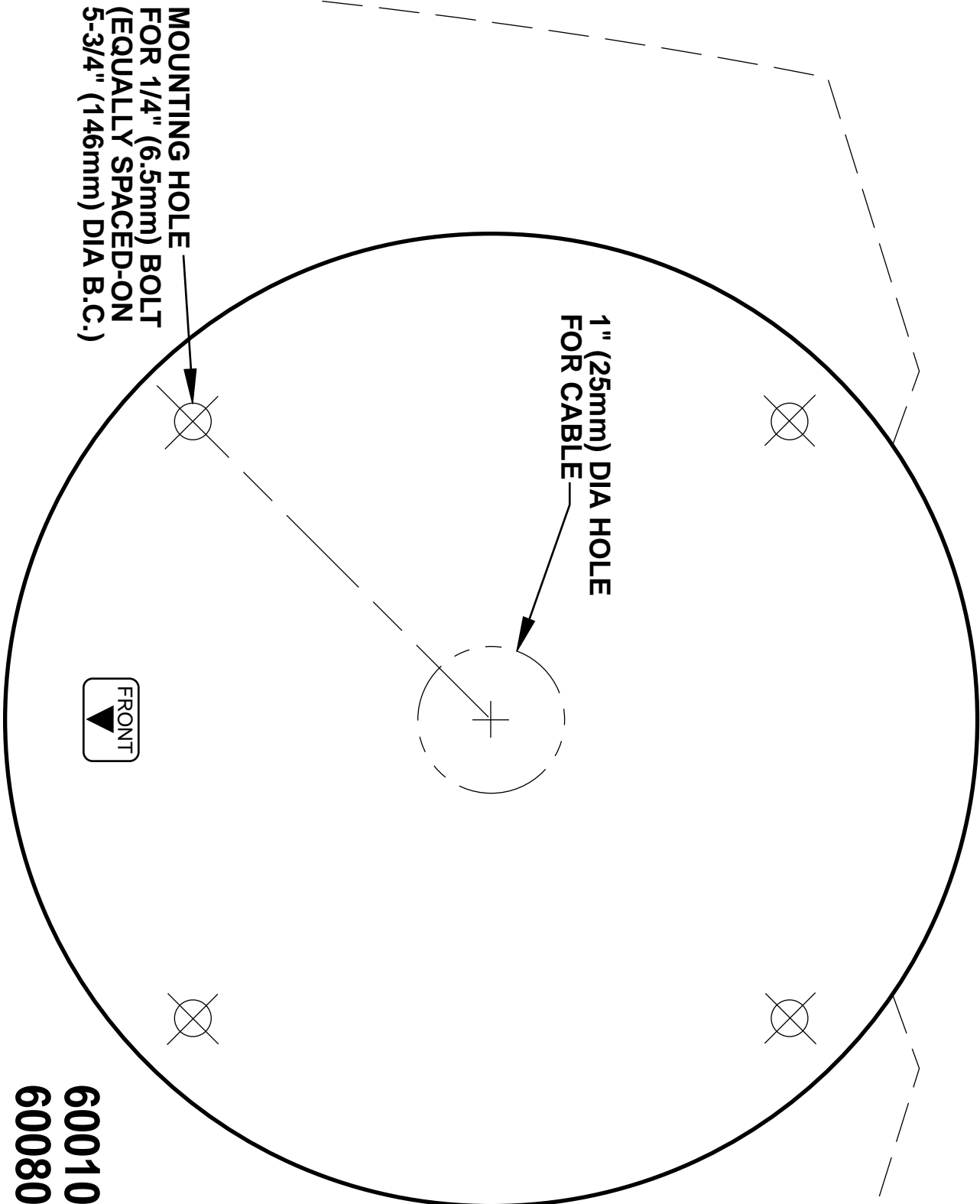

**MOUNTING HOLE  
FOR 1/4" (6.5mm) BOLT  
(EQUALLY SPACED-ON  
5-3/4" (146mm) DIA B.C.)**

**1" (25mm) DIA HOLE  
FOR CABLE**



**60010-Series  
60080-Series  
MOUNTING TEMPLATE**