

JABSCO® UTILITY PUMPS

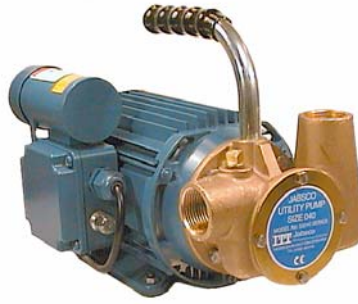

40-size UTILITY PUMP with 1" ports and AC electric motor

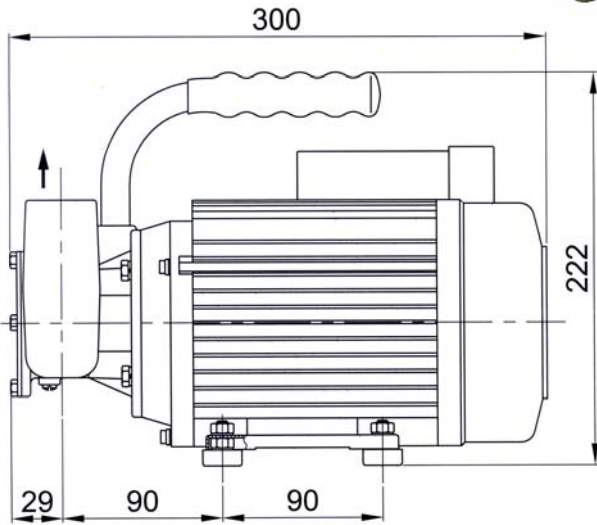

PUMP MODELS

53040-2003	230 volt 1 phase 50Hz 0.25kW
53040-2103	110 volt 1 phase 50Hz 0.25kW
53041-2003-400	400 volt 3 phase 50Hz 0.37kW (No handle)

- ◆ Nitrile oil-resistant impeller fitted as standard.
- ◆ Neoprene impeller version available.

Also available: reduced flow versions for liquid viscosity up to 1000cp. Check with your pump supplier.

SPECIFICATION

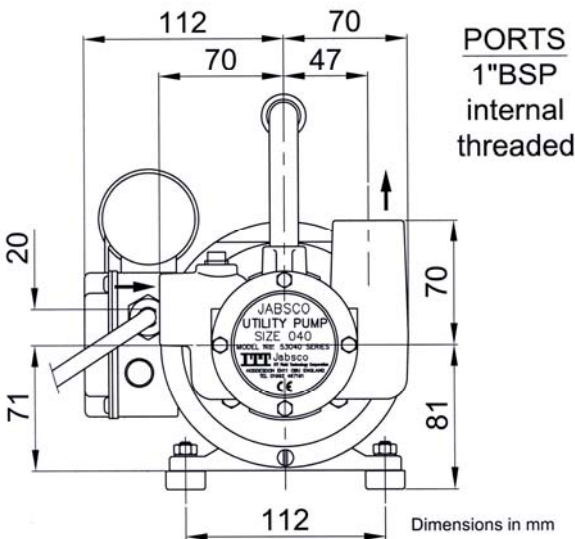

Pump body: bronze
Shaft: AISI316 stainless steel
Shaft seal: mechanical (carbon-ceramic)
Impeller: see pump models above
Max. recommended liquid viscosity: 150cp. Check with your pump supplier if in doubt.
Motor: 4 pole, totally enclosed, fan ventilated, IP54 enclosure. Single-phase motors fitted with manual reset thermal overload cut-out.

Weight: 10.5kg

- ◆ Rapid self-priming up to 3 metres vertical lift.
- ◆ Handles hard and soft solids up to 4mm in size.
- ◆ Can pump up to 90% entrained air.
- ◆ Up to 30 minutes dry running protection.
- ◆ Quick and simple to maintain
- ◆ Light, compact, portable and tough

PUMP PERFORMANCE

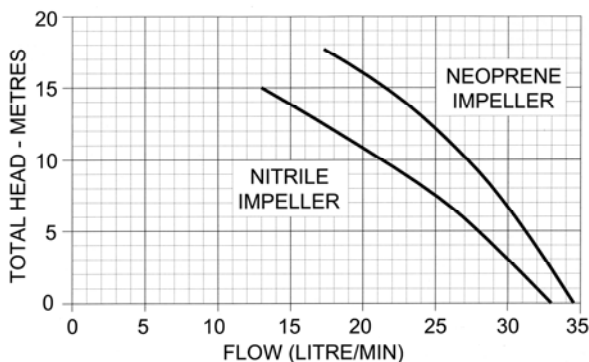

WARNING

Explosive hazard. Do not pump gasoline, solvents, thinners, or other flammable liquids. To do so can cause an explosion resulting in injury or death

Performance figures are based on manufacturer's tests with water and are not guaranteed for any particular application

Product descriptions and specifications are subject to alteration without notice

**JABSCO® RELIABILITY WITH TOP QUALITY PUMP ENGINEERING
- FROM THE UK'S LEADING JABSCO SPECIALIST**