

Exploded View

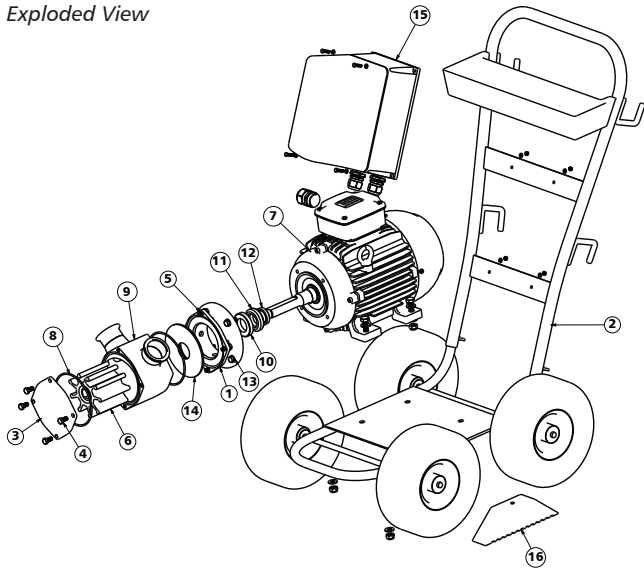

Key	Description	Replacement Part Number
1	Adaptor	28523-1100
2	Cart Assembled	52804-1000
3	End cover	18753-0374
4	Hex head screw (4)	18753-0285
5	Hex head screw (4)	
6	Impeller	8984-0005
7	Motor	52811-1000
8	O Ring	18753-0267
9	Body	28504-1100
10	Seal Seat	18753-0237
11	Seal Mech	18753-0253
12	Spacer (4)	28638-1001
13	Washer	91613-0146
14	Wearplate	18753-0202
15	VFD Inverter	52812-1000
16	Wheel Chock and Cable	52808-1000

PRIMING. Be sure suction lines are airtight or pump will not self prime.

DISCHARGE. When transferring liquids further than 25 feet, use one size larger discharge line than discharge port size.

RUNNING DRY. Unit depends on liquid pumped for lubrication. **DO NOT RUN DRY** for more than 30 seconds. Lack of liquid will damage the impeller.

TEMPERATURES. The operating temperature limits of the pump depend on the impeller compound. The following ranges apply:

EPDM - 45° to 185° F (7° to 85° C).

CLEANING. Before using pump, it should be disassembled and cleaned to remove any dust and dirt resulting from storage or shipping. Wash parts in standard cleaning solutions approved for handling stainless steel. Thoroughly rinse before reassembly.

DO NOT USE IODINE BASED SANITIZERS as the iodine attacks the elastomer materials used in the impeller.

All parts have been expertly machined and polished.
HANDLE WITH CARE. DO NOT DROP OR MISHANDLE.



www.jabSCO.com

UNITED STATES

East Coast
Tel: +1 978 281 0440 Fax: +1 978 283 2619

West Coast
Tel: +1 714 557 4700 Fax: +1 714 628 8478

UNITED KINGDOM

Tel: +44 (0) 1992 450 145 Fax: +44 (0) 1992 467 132

GERMANY

Tel: +49 (0) 40 53 53 73 0 Fax: +49 (0) 40 53 53 73 11

ITALY

Tel: +39 039 6852323 Fax: +39 039 666307

JAPAN

Tel: +81 (0) 45 475 8906 Fax: +81 (0) 45 477 1162

CHINA

Tel: (86)21 2208 2888 Fax: (86)21 2208 2999

28 Series

VERAFLEX™

FLEXIBLE IMPELLER
PUMP CART SYSTEM

Carted pump/VFD system with no remote
52800-1105

Carted pump/VFD system with wired
remote
52800-2105

Carted pump/VFD system with wireless
remote
52800-3105

Pump Head, Flange, Motor
52800-4105

Pump Head, Flange, Motor VFD
52800-5105

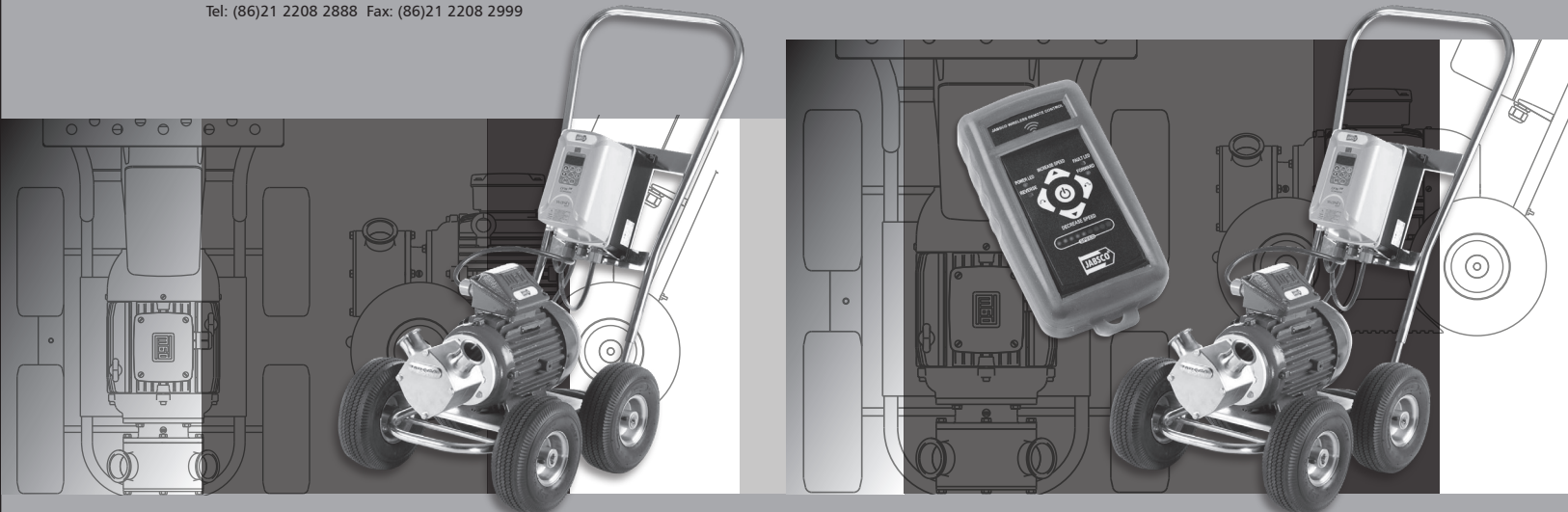

THE PRODUCT DESCRIBED HEREIN IS SUBJECT TO THE JABSCO ONE YEAR LIMITED WARRANTY, WHICH IS AVAILABLE FOR YOUR INSPECTION UPON REQUEST.



SAFETY

This section highlights safety warnings for this product. Warnings listed in this section will be referenced throughout this document. Please review and understand the entire manual before using this product.

	WARNING EXPLOSION HAZARD	
Only used with specified products. DO NOT USE WITH LIQUIDS WITH A FLASH POINT BELOW 100°F (38°C) OR USE WHERE FLAMMABLE VAPORS ARE PRESENT.		
	DANGER	
The inverter control circuit (ECC3,DSP) and the HMI-CFW08-P are high voltage circuits and are not grounded.		
Always disconnect the supply voltage before touching any electrical component inside the inverter.		

Many components are charged with high voltage and/or in movement (fans), even after the incoming AC power supply has been disconnected or switched OFF. Wait at least 10 minutes for the total discharge of the power capacitors.

Always connect the frame of the equipment to the ground (PE) at the suitable connection point.

	ATTENTION	
--	------------------	--

All electronic boards have components that are sensitive to electrostatic discharges. Never touch any of the electrical components or connectors without following proper grounding procedures. If necessary to do so, touch the properly grounded metallic frame or use a suitable ground strap.

No motor or VFD service should be conducted in the field. All inquiries on service for these units should be directed to technical support: 1-877-934-3748

Wireless remote control functions on a 9 VDC battery accessed through the rear battery compartment panel on the hand held remote. For extended battery life, it is recommended to remove the battery if the cart is not to be used for long periods.

DISASSEMBLY

1. Remove the four end cover screws. Remove end cover and O-ring.
2. Remove the four screws, holding the body to the motor adapter flange. Slide body, complete with impeller and wear-plate, from motor shaft assembly.
3. Remove mechanical seal by inserting two screwdrivers behind seal collar, and gently lever collar and seal assembly forward on shaft. Use extreme care not to mar shaft surface.
4. Remove seal seat and rubber cup from recess in wear-plate.

ASSEMBLY

1. Replace mechanical seal by sliding spacer (if new spacer is required or old spacer was removed) onto shaft up to locating shoulder, then lubricate shaft with sanitary lubricant.
2. Push on seal gently until it engages with spacer.
3. Fit rubber cup and seal seat into wearplate.
4. Insert impeller in pump body.
5. Fit O-ring in each end of the pump body.
6. Fit wear-plate to body.
7. Slide wear-plate and body assembly over shaft.
8. Tighten screws to hold body to adapter flange. Torque screws to 10 in. – lbs.
9. Fit end cover, with cover o-ring and end cover screws to body. Torque screws to 60 in. – lbs.

The pump is reversible utilizing the directional change button on the VFD or by reversing the impeller manually.

Changing Pump Rotation (looking at end cover):

Clockwise Rotation: Insert impeller into pump body with blades bending counterclockwise

Counterclockwise Rotation: Insert impeller into pump body with blades bending clockwise.



VERAFLEX™

**FLEXIBLE IMPELLER PUMP CART SYSTEM
HYGIENIC STAINLESS STEEL HEAD PUMP 2"**

Specifications and Features

Pump Type	Close Coupled, 3A
Body	316 Grade Stainless Steel
Impeller	Sanitary Neoprene
Shaft Seal	Mechanical; Carbon-on-Ceramic
Ports	2" Tri-clamp type
Shaft	316 Grade Stainless Steel
Motor	50Hz, 3 HP 112 IEC Frame, Washdown rated, 230 VAC 3 Phase. Maximum RPM 1000.
Variable Frequency Drive	230 VAC 1 Phase input, 50 / 60 Hz
Wireless Remote	Operates on standard 9 VDC battery
Weight pump head	30.0 lb (13.6 kg)
Weight complete unit	159 lb (72.0 kg)
Self primes from dry up to	15' (4.5 meters)
Flows up to	60 GPM (228 LPM)
Pressure up to	37 PSI (2.5 Bar)
Handles viscosities up to	10,000 centipoises

Close coupled hygenics SS pump head/motor/VDF assembly mounted on a 4 wheel cart.

- Certified to US 3A.
- Easy strip clean
- Minimal shear to thixotropic fluids
- Includes basket for fittings, and O-rings
- Includes power cord and remote wire retaining brackets (Plug is supplied by customer).

Operating Instructions

Pump with the Variable Frequency Drive (VFD) will operate from 0 GPM to 60 GPM utilizing the speed control on the wired remote or wireless remote to increase or decrease the motor speed. Please reference WEG CFW-08 manual.

VFD Operation

The VFD is pre-programmed at the factory to meet specification compatible with the pump/motor assembly. No change to the program is possible.

For codes generated on the display of the VFD, or issues that may arise, please see the included WEG manual detailing operations and safety requirements associated with the VFD. The standard CFW-08 keypad has a LED display with 4 digits of 7 segments, 4 status LEDs and 8 keys.

Functions of the LED display: The LED display shows the fault codes and drive status (refer to Quick Parameter Reference, Fault Messages, page 8 – 16 – WEG manual)

Functions of the "Local" and "Remote" LEDs: pages 67 - 71

Functions of the FWD/REV LEDs - Direction of rotation pages 67 – 71

Basic functions of the keys: pages 67 - 71

Pump Cart Maintenance

Pump cart tires are inflatable, Follow max recommended pressures as listed on the tires.

Cart handle height is adjustable to three levels by removing the socket heat cap screws on the vertical riser of the handle tube and adjusting to meet the pre-drilled holes, then reinserting the screws to tighten.

Performance Curve

LTR 7426
Wine Cart Performance Test
with 8984-0005

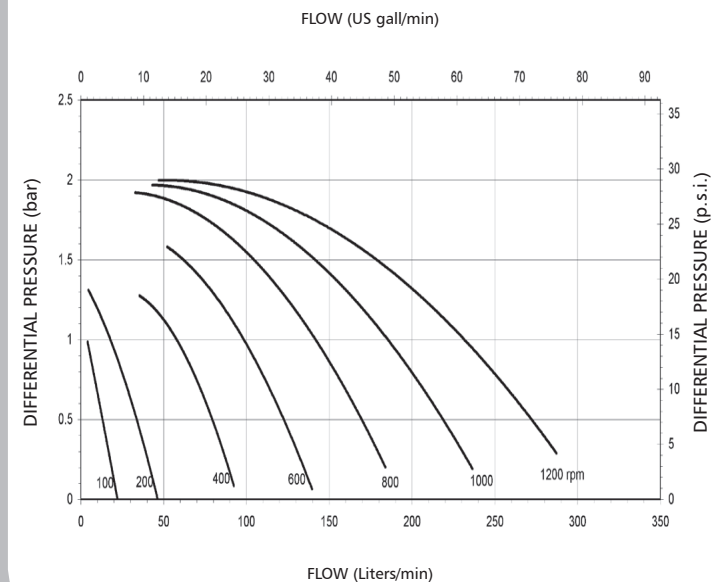

Dimensions

