

51005 Series

Phenolic Flexible Impeller Pump

Features

- Self primes from dry up to 2 metres
- Flows up to 4.5 litres per minute
- Pressure up to 2 bar
- Handles hard or soft solids
- Tolerates abrasive wear
- Non pulsating flow
- Handles viscosities up to 500 centiPoise
- Uses standard IEC motor



Typical Applications

- **Industrial** : Industrial filling systems, utility shop pump, transfer systems, recharge water softeners, sump emptying, cooling tower circulation, line cleaning, heat exchangers, air scrubbers, laboratory circulation, oil changing.
- **Plumbing** : Empty clogged drains, sumps, sinks & tubs, pump out water closets.
- **Contractors** : Cement mixing, wash down equipment, fill & empty tanks, empty basements.
- **Agricultural** : Fill water tanks, flush animal pens, plumbing water for livestock.
- **Food, Beverage & Dairy** : Vending Machines, refrigeration condensate pump out, wash down equipment & floor cleaning.

Specifications

Seal : Nitrile lip seal

Pump Head : Phenolic

End Cover : Phenolic

Bearings : Uses motor bearings

Shafts : Stainless steel shaft extension

Ports : 3/8" NPT Internal or 3/4" NH External

Motor Adaptor : Polypropylene

Weight : 6.2kg

Model Options

Impeller option				Neoprene	Nitrile
Temperature range				4°C to 80°C	-5°C to 90°C
Poles	Volts	Amps	RPM		
4	230	2.13	1450	51005-9401	
4	115	4.20	1450		
Pump head only				51005-00-9401	

Motors are single phase, 180 Watt, 50 Hertz, AC. Face & Foot mounting B3-B14.

Enclosure IP55, frame size 63 all IEC 72 standard. Fitted with manual reset thermal overload.

Note : it is not recommended to start the pump at extreme ends of the temperature range, impeller damage may occur

For Installation, Operating, Maintenance and Safety Instructions refer to form 43001-0543

 **WARNING** Explosion hazard. Do not pump gasoline, solvents, thinners or other flammable liquids. To do so can cause an explosion resulting in injury or death.

 **WARNING** Fire hazard. Wiring must comply with applicable electrical standards and include a properly sized fuse or circuit breaker. Improper wiring can cause a fire resulting in injury or death

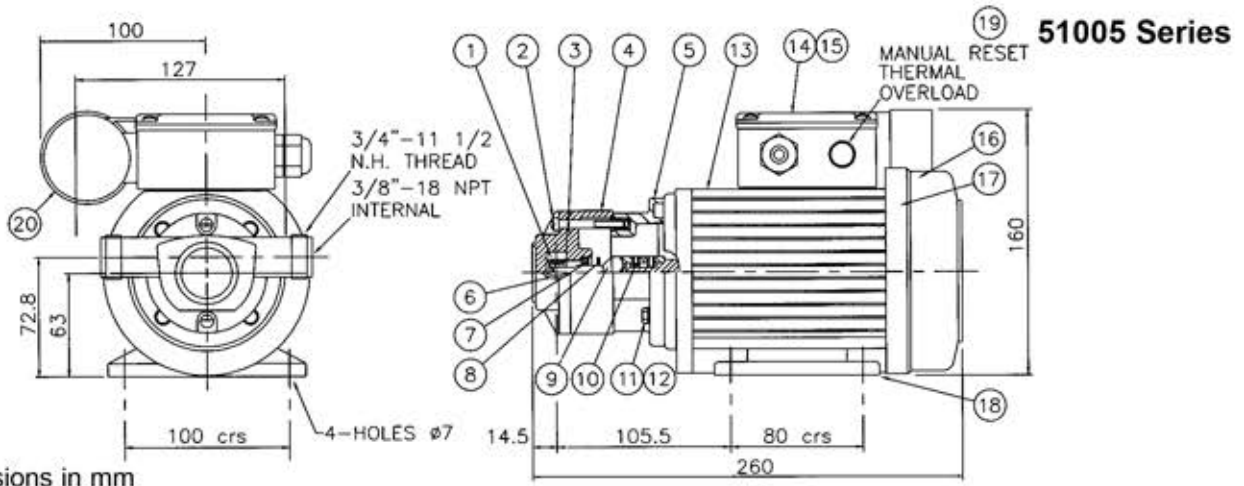

Dimensions in mm

Parts List

Key	Description	Qty	Part Number
1	Impeller *	1	See right
2	Screw * Body	2	X5258-005
3	O'Ring *	1	SP2000-0750
4	Seal Housing	1	12314-0000
5	Motor Adaptor	1	50168-0000
6	Body	1	12375-000
7	Lip Seal *	1	SP2701-52
8	Slinger	1	6342
9	Shaft Extension	1	50167-0000
10	Set Screw Shaft	2	X3009-093F
11	Screw M5 x 16	4	X3001-153F
12	Washer	4	X3080-081F
13	Motor	1	SP8012-0260

Parts marked * are contained in a Service Kit

Commonly used spare parts & service kit numbers

Elastomers	Neoprene	Nitrile
Impeller key 1	14792-0001	14792-0003
Service kit contains parts shown above	SK420-0401	

Models with Neoprene Impeller use Nitrile Lip Seal

Performance

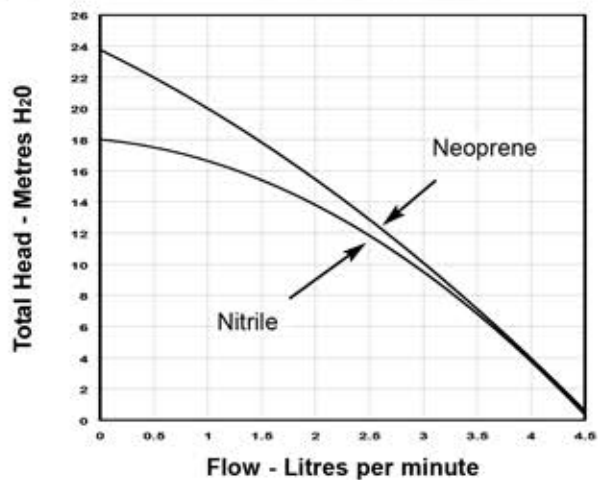

Note : Performance shown is for a new pump, pumping water at 20°C, performance may vary by up to 15%. Consult factory for performance of alternative impeller compounds.

Jabsco

USA

Jabsco
20 Icon
Foothill Ranch
CA 92610

Tel : +1 949 859 4945
Fax : +1 949 859 1153

UK

Jabsco
Bingley Road
Hoddesdon
Hertfordshire, EN11 0BU

Tel : +44 (0) 1992 450 145
Fax : +44 (0) 1992 467 132

GERMANY

Jabsco GmbH
Oststraße 28
22844 Norderstedt

Tel : +49 (0) 40 53 53 73 0
Fax : +49 (0) 40 53 53 73 11