

**NEW!**



**ITT**



## Flush Mount Halogen Floodlight

LIGHT THE NIGHT



### FOR COCKPIT, DECK AND BOARDING POINT ILLUMINATION FOR LEISURE, COMMERCIAL, FISHING AND SAFETY CRAFT

ITT Jabsco is pleased to announce the introduction of our new Flush Mount Halogen Floodlight. Designed specifically for the rigors of the marine environment, it features an exclusive weather-proof "full boot seal" to protect the wire contacts from corrosion.

Finely styled to integrate with contemporary yacht designs, the new floodlight is both attractive and tough. Constructed of shock and vibration resistant materials with a U.V. stable housing to eliminate "yellowing", the floodlight will provide many years of dependable service even in the toughest conditions.

Best of all are its superior lighting characteristics. The 45° x 20° flood beam pattern has sharp edge cut-offs to reduce stray lighting with no "hot spots", providing uniquely even lighting. The new Jabsco Flush Mount Floodlight is the smart choice for cockpit, deck and boarding point illumination for leisure, commercial, fishing and safety craft.

#### Features and Benefits

- 3" x 5" (76mm x 127mm) 50 watt sealed beam halogen
- 45° x 20° flood beam pattern
- U.V. stable materials for non-yellowing
- Heavy duty shock and vibration resistant construction
- Weather-proof "full boot" seal protects wire contacts



*Engineered for life*

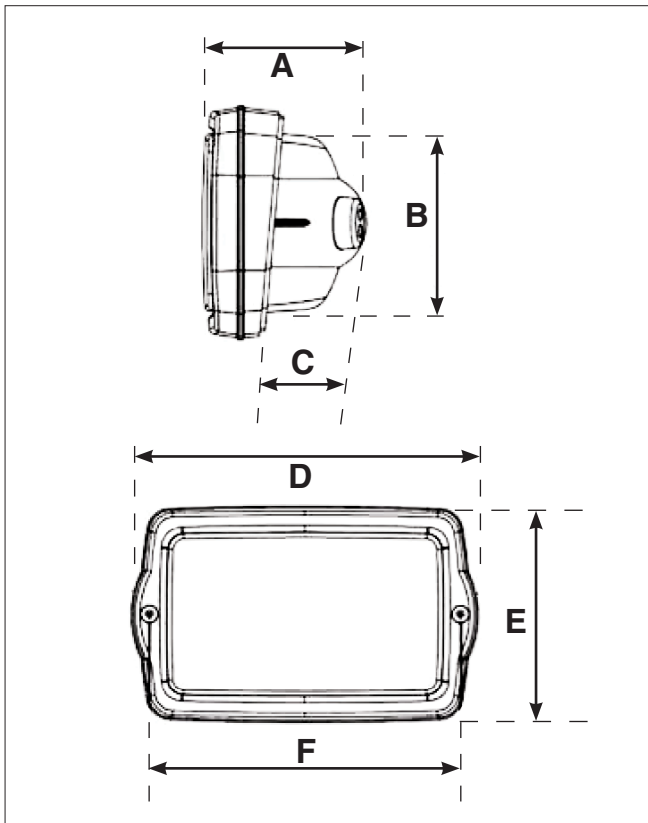

**SPECIFICATIONS**

**Models:** 45930-2012, 3 x 5 Flush Mount - Angled Back  
 45930-2512, 3 x 5 Flush Mount - Straight Back

**Beam Angle:** 45° x 20°

**Voltage:** 12 VDC

**Amperage:** 3.8 @ 12 VDC; 4.1 @ 13.6 VDC

**Watts:** 50

**Size:** 6-3/4" long x 4-1/4" high x 2-3/4" deep;  
 (95mm x 108mm x 70mm)

**Weight:** 1 lb. (.45 kg.)

**Conformance:** CE

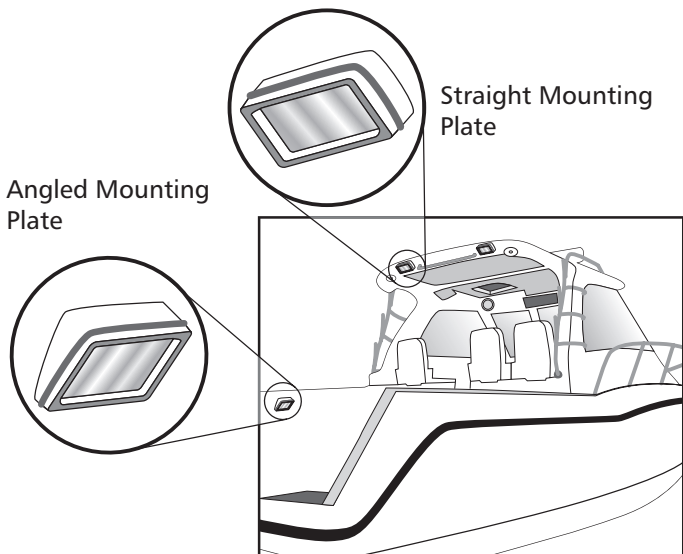

3" x 5" (76mm x 127mm)			
A	3" (84mm)	D	6-3/4" (171mm)
B	3-7/32" (92mm)	E	4-1/4" (108mm)
C	1-11/16" (43mm)	F	6-7/32" (157mm)



Engineered for life

[www.jabsco.com](http://www.jabsco.com)

**USA**  
 ITT Corporation  
 Cape Ann Industrial Park  
 Gloucester, MA 01930  
 Tel: (978) 281-0440  
 Fax: (978) 283-2619

**UK**  
 ITT Industries  
 Bingley Road, Hoddesdon  
 Hertfordshire EN11 0BU  
 Tel: +44 (0) 1992 450145  
 Fax: +44 (0) 1992 467132

**GERMANY**  
 ITT Corporation  
 Oststrasse 28  
 22844 Norderstedt  
 Tel: +49-40-53 53 73-0  
 Fax: +49-40-53 53 73-11

**JAPAN**  
 NHK Jabsco Company Ltd.  
 3-21-10, Shin-Yokohama  
 Kohoku-Ku, Yokohama, 222-0033  
 Tel: +81-045-475-8906  
 Fax: +81-045-477-1162

**ITALY**  
 ITT Corporation  
 Via Tommaseo, 6  
 20059 Vimercate, Milano  
 Tel: +39 039 685 2323  
 Fax: +39 039 666 307

Warranty: All products of the company are sold and all services of the company are offered subject to the company's warranty and terms and conditions of sale, copies of which will be furnished upon request. The information provided herein is for guidance only, it does not constitute a guarantee of the performance or specification of any individual product or component.