

# JABSCO®

## Model 41750 / 41755 - Series

### VSD WATER PRESSURE SYSTEM PUMP

#### FEATURES

- High Capacity Variable Speed Drive Water System Pump
- 6.0 GPM or 7.5 GPM (23 or 29 LPM) Models for 5+ fixtures
- Solid state pressure sensor
- 12VDC & 24VDC models available
- Sensor-controlled to automatically adjust for changes in system pressure
- Operating pressures to 60 psi (4.1 bar)
- Smooth flow; no cycling or water hammer
- Self-priming up to 6 feet (1.8 m) / runs dry
- Eliminates need for space consuming accumulator tank
- Protected under U.S. Patent #6,607,360
- Other Patents Pending
- Includes Pumpgard™ Inlet Strainer
- ISO 8846 MARINE (ignition protection)
- CE



#### SPECIFICATIONS

- Pump Body: Glass Filled Nylon
- Pump Design: 5 Chamber Diaphragm
- Suction Lift: Self Priming to 6 ft. (1.8m)
- Ports: (2) 3/4" (19 mm) straight Hose Barb, (2) 1/2"- 14 QEST Straight, (2) 3/4" (19 mm) Hose Barb 90° Elbow, (2) 1/2"- 14 QEST 90° Elbow
- Motor: Permanent Magnet

MODEL	VOLTS	AMP DRAW (A)	FUSE SIZE (A)	OPEN FLOW GPM (LPM)	CUT-OUT PRESSURE PSI (BAR)	INLET STRAINER
41750-0092	12VDC	16	20	6.0 (23)	60 (4)	Yes
41750-0094	24VDC	8	15	6.0 (23)	60 (4)	Yes
41755-0092	12VDC	24	30	7.5 (29)	60 (4)	Yes
41755-0094	24VDC	11	15	7.5 (29)	60 (4)	Yes



VSD WATER PRESSURE SYSTEM PUMP  
Dimensions English (SI)

Pump Series	Height inches (mm)	Length inches (mm)	Width inches (mm)	Weight Lb (Kg)
41750	7.3 (186)	11.8 (300)	6.1 (155)	8.0 (3.6)
41755	7.3 (186)	10.2 (259)	6.1 (155)	10.0 (4.5)

41750 / 41755 - Series

#### DIMENSIONAL DRAWING

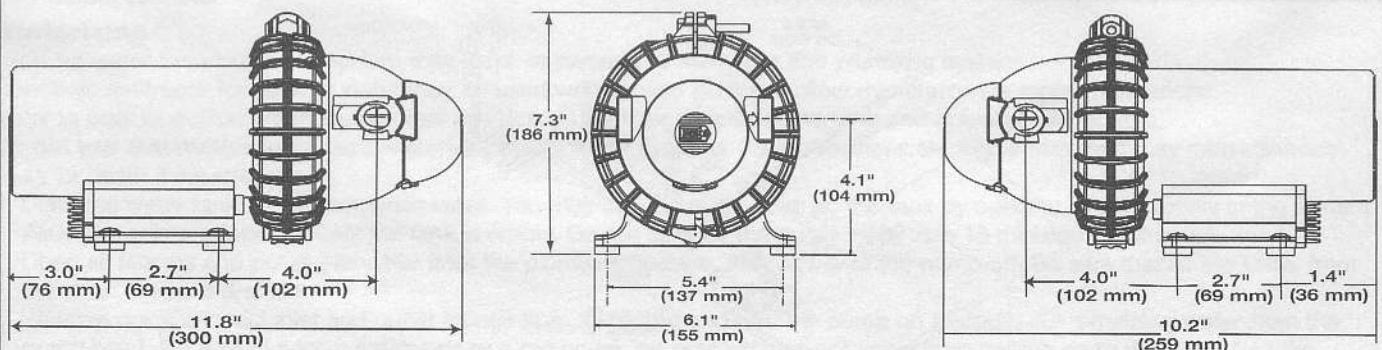

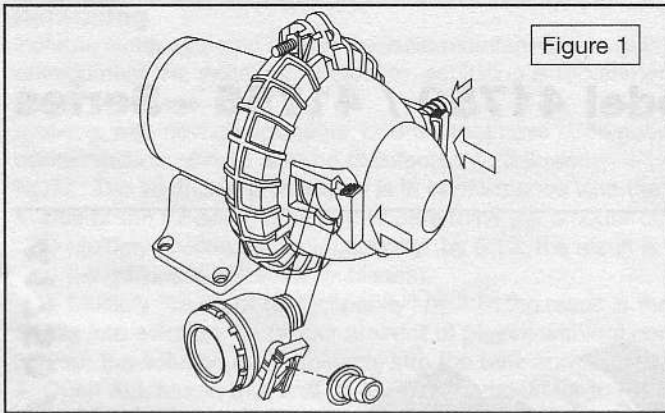

Figure 1

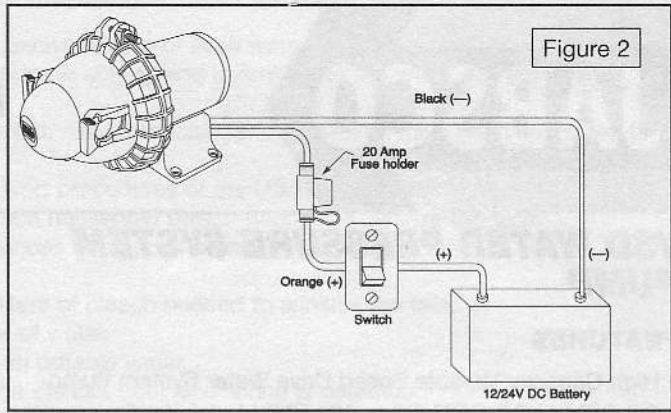

Figure 2

**INSTALLATION (FIG.1)**

Remove the shipping plugs from the 41750/41755 Series pump ports. Some water from factory testing may spill out. Install strainer on inlet and port adapter on outlet. Firmly push slide clips in to lock strainer and port adapter in place. Install port adapter to strainer inlet (not shown) and firmly push slide clip to lock port adapter. Mount pump horizontally, or vertically with the pump-head lower than the motor. Any plumbing leak should not drip on the motor.

Use 3/4" I.D. hose (preferably braided or reinforced) to isolate pump vibration from plumbing system, and use a worm screw hose clamp for hose connection to all fittings

**WIRING (FIG.2)**

**STEP 1**

Use 14 AWG (2.5 mm<sup>2</sup>) stranded wire to 10 feet (3 m).

**STEP 2**

Install a 30 amp rated on-off switch on the positive (+) lead from the power source.

**STEP 3**

Use as required breaker in the circuit at the distribution panel.

**STEP 4**

Connect the red lead to the red/orange lead on the pump housing located pressure switch.

**STEP 5**

Connect the black lead from the pump to the ground or negative power side (-) of the vessel.

**STEP 6**

Turn the system off when not in use for extended periods of time or when the water supply tank is empty.

**STEP 7**

After installation, check voltage at the pump motor. Voltage should be checked when pump is operating. Full voltage must be available at the pump motor at all times for proper pump operation and pump motor life.

**OPERATION**

Mount the pump in a dry, ventilated location. The inlet strainer must be installed between the fresh water supply and the pump inlet port. The supply tank should be at least half full prior to initial operation.

**NOTE:** The VSD electronics require a battery installed in the DC power supply when using an AC to DC converter or battery charging system.

**IMPORTANT:** Polarity of electrical connections is very important. Insure that the orange (+) motor lead is connected to a fused positive DC circuit. The BLACK (-) motor lead must be connected to the negative DC circuit. In the event that polarity is reversed, the in-line fuse must be replaced. To prime the plumbing system, open all the faucets and turn on the power to the pump. Shut off each faucet as it begins to run free of air. As the last faucet is closed the pump will slow down and shut off.

**IT IS RECOMMENDED THAT MARINE GRADE REINFORCED HOSE BE USED FOR ALL PLUMBING WITH THESE MODELS OF WASHDOWN PUMPS**

**IF YOU ARE NOT FAMILIAR WITH APPLICABLE ELECTRICAL STANDARDS, HAVE THE UNIT INSTALLED BY A QUALIFIED ELECTRICIAN.**

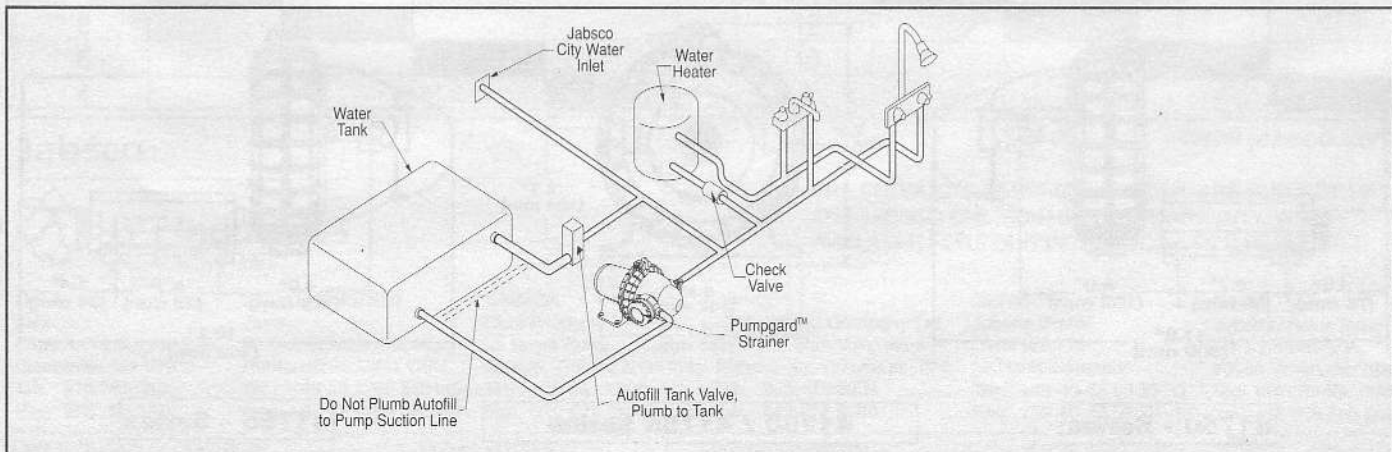

## EXPLODED VIEW

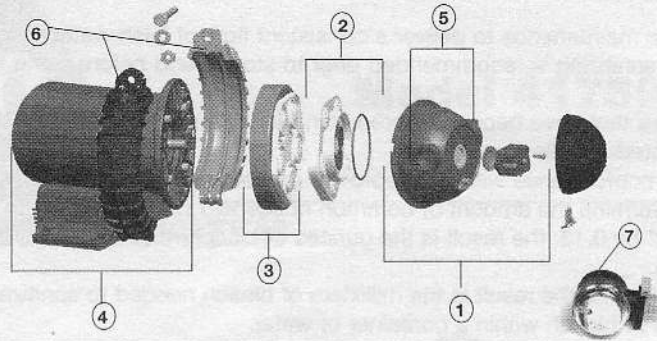

## SERVICE PARTS

Key	Description	Part Number	
		41750 - XXXX	41755 - XXXX
1	Upper Housing	18753 - 5012	18753 - 5012
2	Check Valve Assembly	18753 - 5006	18753 - 5006
3	Lower Housing Assembly	18753 - 5038	18753 - 5038
4	Motor With Baseplate and VSD Module	(12V) 18753 - 5022 (24V) 18753 - 5027	18753 - 5026 18753 - 5029
5	Clips	18753 - 5021	18753 - 5021
6	Clamps	18753 - 5018	18753 - 5018
7	Strainer	46400 - 0711	46400 - 0711

## TROUBLESHOOTING



**WARNING: BEFORE SERVICING PUMP, TURN OFF POWER TO PUMP AND DRAIN SYSTEM!!**

### Failure to Prime - Motor operates, but no water flows Remedy

- Debris in pump:
- Defective check valve assembly:
- Air leak in intake line:
- Restricted intake or discharge line:
- Punctured diaphragm (pump leaks):
- Crack in pump housing (pump leaks):
- Empty water supply tank:

Remove upper-housing and clean  
Replace check valve assembly  
Tighten all clamps, inspect plumbing  
Remove lines and inspect  
Replace lower housing assembly  
Replace housing or pump head  
Refill or turn off power to pump

### Motor fails to run

- Pump circuit has no power:
- Loose or corroded wiring connection:
- Blown fuse or open breaker:
- Open thermal protector (motor shell hot):
- Defective motor:

Check wiring, fuse or breaker  
Inspect wire connections  
Replace or reset  
Wait 20 to 30 minutes for auto reset  
Replace motor

### Pump fails to turn off after all fixtures are closed

- Empty water supply tank:
- Air trapped in pump:
- Debris in pump:
- Defective check valve assembly:
- No battery in Circuit:
- Punctured diaphragm (pump leaks):
- Discharge line leak:

Refill  
Open faucet closest to pump  
Remove upper-housing and inspect  
Replace check valve assembly  
Install battery  
Replace lower housing assembly  
Inspect plumbing for leaks

### Low flow or pressure

- Debris in inlet strainer:
- Water filter needs changing:
- Under sized plumbing or long runs:
- Defective motor:

Remove cover and clean screen  
Replace filter cartridge  
Increase plumbing I.D.  
Replace motor

## Winterizing

Allowing water to freeze in the system may result in damage to the pump and plumbing system.

Non-toxic antifreeze for potable water may be used with Jabsco pumps. Follow manufacturers recommendations.

Refer to boat or equipment manufacturers instructions for their specific winterizing and drainage procedures.

**Do not use automotive antifreeze** winterize potable water systems. These solutions are highly toxic and may cause serious injury or death if ingested.

1. Drain the water tank. Open tank drain valve. You may use the pump to drain the tank by opening all the faucets in the system. Allow the pump to operate until the tank is empty. Do not operate the pump more than 15 minutes continuously.
2. Open all faucets and purge the water from the plumbing system. Turn power to the pump off. Be sure that all the water from the drain lines are drained.
3. Remove quick connect inlet and outlet fittings from the pump and turn the pump on to pump out remaining water from the pump head. Be sure to have a catch pan or a rag under the pump to prevent water from spilling on to the boat. Turn the pump off once the plumbing is empty. Leave the fittings disconnected from the pump until the system is ready to be used again. Make a note on your tank filler that the plumbing is not connected.
4. Be sure that all faucets are left open to protect against damage to the plumbing.

## Sanitizing

Potable water systems require periodic maintenance to deliver a consistent flow of fresh water. Depending on use and the environment the system is subject to, sanitizing is recommended prior to storing and before using the water system after a period of storage.

systems with new components, or ones that have been subjected with new components, or ones that have been subjected to contamination, should also be disinfected as follows:

NOTE: The sanitizing procedures is in conformance with the approved procedures of the US Public Health Service.

1. Use of the following methods to determine the amount of common household bleach needed to sanitize the tank.

A) Multiply "gallons of tank capacity" by 0.13; the result is the ounces of bleach needed to sanitize the tank (50 gallons X .13 = 6.5 oz bleach).

B) Multiply "Liters of tank capacity" by 1.0; the result is the milliliters of bleach needed to sanitize the tank.

2. Mix into solution the proper amount of bleach within a container of water.

3. Pour the solution (water/bleach) into the tank and fill the tank with potable water.

4. Open ALL faucet (hot and cold) allowing the water to run until the distinct odor of chlorine is detected.

5. The standard solution must have four (4) hours of contact time to disinfect completely. Doubling the solution concentration allows for contact time of one (1) hour.

6. When the contact time is completed, drain the tank. Refill with potable water and purge the plumbing of all sanitizing solution.

## ACCESSORIES

### Quick - Connect Port System

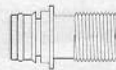

**50644 - 1000**  
(1 PAIR)  
SNAP - IN X  
1/2" - 14  
MALE PIPE  
STRAIGHT

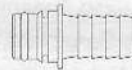

**50642 - 1000**  
(1 PAIR)  
QUAD PORT X  
3/4" (19 mm)  
HOSE BARB  
STRAIGHT

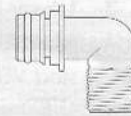

**50645 - 1000**  
(1 PAIR)  
QUAD PORT X  
1/2" - 14  
MALE PIPE  
90° ELBOW

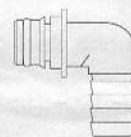

**50643 - 1000**  
(1 PAIR)  
QUAD PORT X  
3/4" (19 mm)  
HOSE BARB  
90° ELBOW

## Wiring Guide For 5 - Chamber Pump

These charts reflect the 3% voltage drop classifications appearing in ABYC's E-11 AC & DC ELECTRICAL SYSTEMS ON BOATS. Wire resistances were taken from NFPA NEC 2002 Handbook, Table 8. The percentage voltage drops will approximate percentage reductions in open flow from ideal

<b>41750 - 0092</b>	<b>Operating Current: 16 A</b>
	<b>Fuse Size: 20 A</b>

Wire sizing for 3% voltage drop, 1-way wiring run				
AWG	5'	10'	15'	20'
12	■			
10		■		
8			■	
6				■

<b>41750 - 0094</b>	<b>Operating Current: 8 A</b>
	<b>Fuse Size: 15 A</b>

Wire sizing for 3% voltage drop, 1-way wiring run				
AWG	15'	20'	35'	50'
14	■			
12		■		
10			■	
8				■

<b>41755 - 0092</b>	<b>Operating Current: 24 A</b>
	<b>Fuse Size: 30 A</b>

Wire sizing for 3% voltage drop, 1-way wiring run				
AWG	5'	7.5'	10'	20'
10	■			
8		■		
6			■	
4				■

<b>41755 - 0094</b>	<b>Operating Current: 11 A</b>
	<b>Fuse Size: 15 A</b>

Wire sizing for 3% voltage drop, 1-way wiring run				
AWG	7.5'	10'	20'	30'
14	■			
12		■		
10			■	
8				■

Jabsco

[www.jabsco.com](http://www.jabsco.com)



**ITT Industries**  
*Engineered for life*

THE PRODUCTS DESCRIBED HEREIN ARE SUBJECT TO THE JABSCO ONE YEAR LIMITED WARRANTY, WHICH IS AVAILABLE FOR YOUR INSPECTION UPON REQUEST.

U.S.A.  
Jabsco  
Cape Ann Industrial Park  
Gloucester, MA 01930  
Tel: 978.281.0440  
Fax: 978.283.2619

UNITED KINGDOM  
Jabsco  
Bingley Road, Hoddesdon  
Hertfordshire EN11 0BU  
Tel: +44 (0) 1992 450145  
Fax: +44 (0) 1992 467132

CANADA  
Fluid Products Canada  
55 Royal Road  
Guelph, Ontario N1H 1T1  
Tel: 519 821.1900  
Fax: 519 821.2569

JAPAN  
NHK Jabsco Company Ltd.  
3-21-10, Shin-Yokohama  
Kohoku-Ku, Yokohama, 222  
Tel: 045.475.8906  
Fax: 045.475.8908

GERMANY  
Jabsco GmbH  
Oststrasse 28  
22840 Norderstedt  
Tel: +49-40-53 53 73 -0  
Fax: +49-40-53 53 73 -11

ITALY  
Jabsco Marine Italia  
Via Tommaseo, 6  
20059 Vimercate, Milano  
Tel: +39 039 685 2323  
Fax: +39 039 666 307