

DESIGNER STYLED MARINE TOILET

Model 37275-Series

FEATURES

- Very quiet flush cycle- like a household toilet
- Single button flush actuator- with dual function water level control switch
- Supplied with Par-Max 4 self-priming pump to provide sea water or lake water to rinse the toilet bowl
- Vitreous china bowl available in compact 14" height or standard 17" height
- Available in White or Bone
- Baked enamel seat & cover
- High capacity waste macerator and bowl discharge pump
- All toilet plumbing and wiring connections are internal-out of sight

SPECIFICATIONS

Ports: PAR-MAX Pump and Toilet
 Inlet- 3/4" Hose Barb
 Outlet-1" Hose Barb

Motor & Switch: Pump and Toilet Meet U.S.C.G. Regulation 183.410 and ISO 8846 Marine for Ignition Protection.
 Toilets are marked **CE** and comply with EN50081-1 for suppression of electro-magnetic interference.

Normal Water Consumption: 1-2 Quarts (Litres)/Flush

OPERATION

The Designer Styled Toilets with the popular Quiet-Flush system provide both quiet operation and user control of water levels in the toilet bowl. A single large push-button switch provides a simple flush mode by activating both the rinse water supply and the macerator discharge pump simultaneously. An additional rocker switch offers independent control of the rinse water supply and discharge pump separately so the bowl water level can be easily raised or lowered by the user. This provides a method of minimizing water use, when desired, as well as a means of raising the water level in the bowl when appropriate for user comfort. It also allows for complete evacuation of the bowl water while underway in rough sea conditions.



Model Number	Description
37275-0092	Compact White Toilet 14", 12 Volt EMC
37275-0094	Compact White Toilet 14", 24 Volt EMC
37275-1092	Standard White Toilet 17", 12 Volt EMC
37275-3092	Standard Bone Toilet 17", 12 Volt EMC
37275-1094	Standard White Toilet 17", 24 Volt EMC
37275-3094	Standard Bone Toilet 17", 24 Volt EMC

INSTALLATION

The 37275-Series Designer Styled Toilet includes the Quiet-Flush Toilet pumping system and is supplied with a dedicated PAR-MAX 4 pump to provide either sea or lake water to rinse the toilet bowl when flushing the toilet. This pump is intended to be located remotely from the toilet but will function best if the distance from the toilet is kept to a minimum. Because it is self-priming, it may be located above the vessel's waterline. It must be installed with the Pumpgard strainer (provided with the toilet) located somewhere in the inlet plumbing to the pump. The toilet also includes a multi-function flush control which should be installed in a bulkhead location that is convenient to the toilet and allows access for wiring to run from the power source and to both the toilet discharge pump and PAR-MAX rinse water pump. Because all plumbing and wiring connections at the toilet are made internally within the china bowl, all plumbing and wiring must be completed and extended to the toilet location prior to final installation of the toilet.

Install the toilet seat and lid assembly on the china bowl with the fasteners provided and position the toilet in its desired location. When locating the toilet, ensure there is adequate clearance above the bowl so the seat and lid assembly can rotate to its fully open position and remain open on its own. Once the exact position has been determined, mark the location of the two toilet mounting holes on the toilet mounting surface and move the toilet temporarily out of the way. When securing the toilet to a plywood underlayment below a layer of fiberglass, to avoid cracking the fiberglass, drill a 5/16" (8 mm) hole through just the fiberglass layer to provide clearance for the screw threads and shank. Drill a 3/16" (5 mm) pilot hole to accept the threaded portion of the toilet hold down screw set provided. It is generally best to wait until the toilet is ready to be installed for the final time before screwing the hold down screws into the mounting surface.

The PAR-MAX pump should be mounted to a solid mounting surface. It should be secured with four fasteners through the rubber grommets that snap into the pump's base. Do not over-tighten the mounting screws and crush the grommets such that they will not absorb vibration. The pump may be mounted in any position; however, if mounting it to a vertical surface it should be oriented so water dripping from a loose port connection will not drip down on the motor. Plumbing runs should be kept as short and straight as possible. All plumbing should be completed with quality 3/4" (19 mm) hose that will not collapse or kink. Route the inlet hose from a 3/4" (19 mm) through hull and seacock fitting located well below the waterline (and well forward of any discharge through hulls, if installed) to the pump inlet port.

Ensure the inlet hose passes through an accessible location (preferably above the vessel's water-line) that will allow for the installation of the Toilet Pumpgard strainer where it can be periodically inspected and cleaned of debris. The Pumpgard strainer should be secured with two fasteners to a solid mounting surface with the flow arrow pointing towards the pump. The inlet hose should be cut and each end attached to the strainer's ports. Connect the hose from the discharge port of the strainer to the PAR-MAX pump's inlet port. Connect another length of hose from the pump's discharge port to the area at the back of the Designer Styled Toilet with adequate length to connect with the 3/4" (19 mm) hose barb at the back of the china bowl.

	<p>WARNING</p> <p>Flood hazard. If toilet is installed below the waterline or may be below the waterline at any angle of heel or trim, it must be installed with properly positioned vented loops. Failure to do so can result in flooding which can cause loss of property and life.</p>
---	--

If the toilet is installed below the vessel's waterline, in order to prevent a siphon action from filling the toilet, a properly positioned vented loop fitting must be installed between the PAR-MAX pump and the back of the toilet bowl.

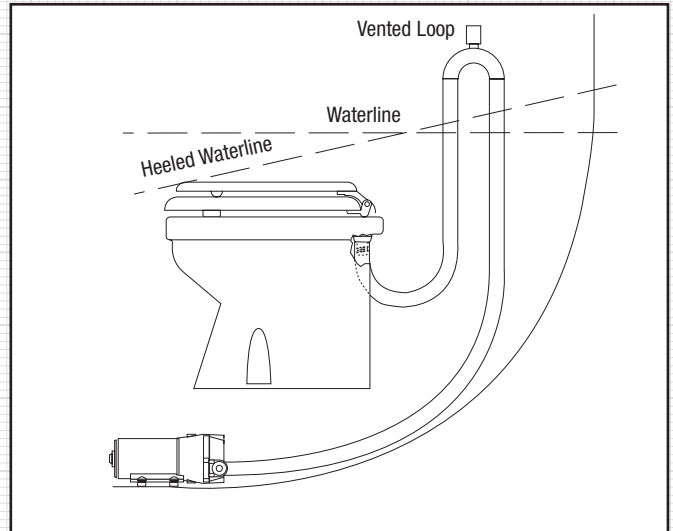

The vented loop fitting must be secured in a location that remains at least 6-8 inches (15-20 cm) above the waterline at all angles of heel and trim (see diagram).

The toilet discharge port is sized for 1" (25 mm) hose. The discharge hose should be a quality grade reinforced hose suitable for waste applications. Route the discharge hose to the holding tank in the most direct way with as few bends as possible. To retain some water in the bowl, it is best to loop the discharge hose up about 8-10 inches (15-20 cm) as close to the toilet as practical then on to the holding tank. Providing adequate length of hose to include such a loop also will provide the ability to move the toilet out away from the bulkhead it butts against to complete the hose connections. It is best to avoid any dips or low spots in the discharge plumbing that can act as water traps and collect waste. If this occurs, waste can solidify and cause a discharge blockage.

	<p>WARNING</p> <p>Flood hazard. If toilet is installed below the waterline or may be below the waterline at any angle of heel or trim, it must be installed with properly positioned vented loops. Failure to do so can result in flooding which can cause loss of property and life.</p>
---	--

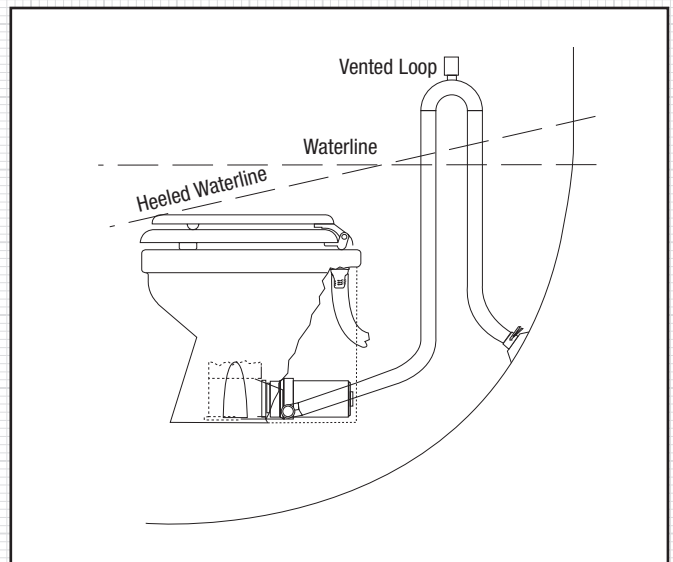

If the toilet is plumbed to an overboard discharge, and is below the vessel's waterline, the discharge plumbing must include a properly positioned vented loop. The vented loop fitting must be secured in a location that remains at least 6-8 inches (15-20 cm) above the waterline at all angles of heel and trim. The maximum discharge head without a notable decrease in pump performance is four feet (1.3 M).

Ensure each hose end is pushed completely onto its port fitting and secure each with a hose clamp. All hose connections made below the waterline should be secured with two stainless steel clamps. It is best to secure the hoses in place about every eighteen inches along the length of the run.

Once all hose connections are completed and secured with clamps, it is best to complete the wiring so the toilet can be tested for leaks prior to fastening it to its mounting surface. Once the electrical wiring is complete, test the toilet by flushing several times and blot all hose termination's completely around each connection with a white paper towel and inspect the towel for wet spots. If the towel comes away dry from each connection within the china bowl, proceed to fasten the toilet to its mounting surface.

Position the toilet in its intended mounting position and very gently, with a 10 mm wrench, screw the provided toilet hold-down fastener into the pilot hole drilled earlier. Do not overtighten these fasteners as this may crack the china. It is only necessary to make the fasteners snug enough to prevent the toilet from sliding around. Screw the dress cap into the top of the hold-down screw.

ELECTRICAL

The electrical wiring should be independent of all other accessories. It should be made with marine grade copper stranded wire of the gauge specified in the electrical specifications chart. Make all wire connections with mechanical locking type connectors (crimp type butt connectors and terminals).

Ensure the circuit is protected by a proper sized fuse or circuit breaker determined from the electrical specifications chart. Secure all wires to a solid surface approximately every eighteen inches (1/2 M) along their entire length of run.

ELECTRICAL SPECIFICATIONS

VOLTAGE	AMP DRAW	FUSE SIZE	WIRE SIZE PER FEET OF RUN*				
			0'-10' (0 M-3 M)	10'-15' (3 M-4,6 M)	15'-25' (4,6 M-7,6 M)	25'-40' (7,6 M-12,2 M)	40'-60' (12,2 M-18,3 M)
12 Vdc	10	25	#16 (1,5 mm ²)	#14 (2,5 mm ²)	#12 (4 mm ²)	#10 (6 mm ²)	#8 (10 mm ²)
24 Vdc	5	15	#16 (1,5 mm ²)	#16 (1,5 mm ²)	#16 (1,5 mm ²)	#14 (2,5 mm ²)	#12 (4 mm ²)

* Length of run is total distance from power source to product and back to ground.

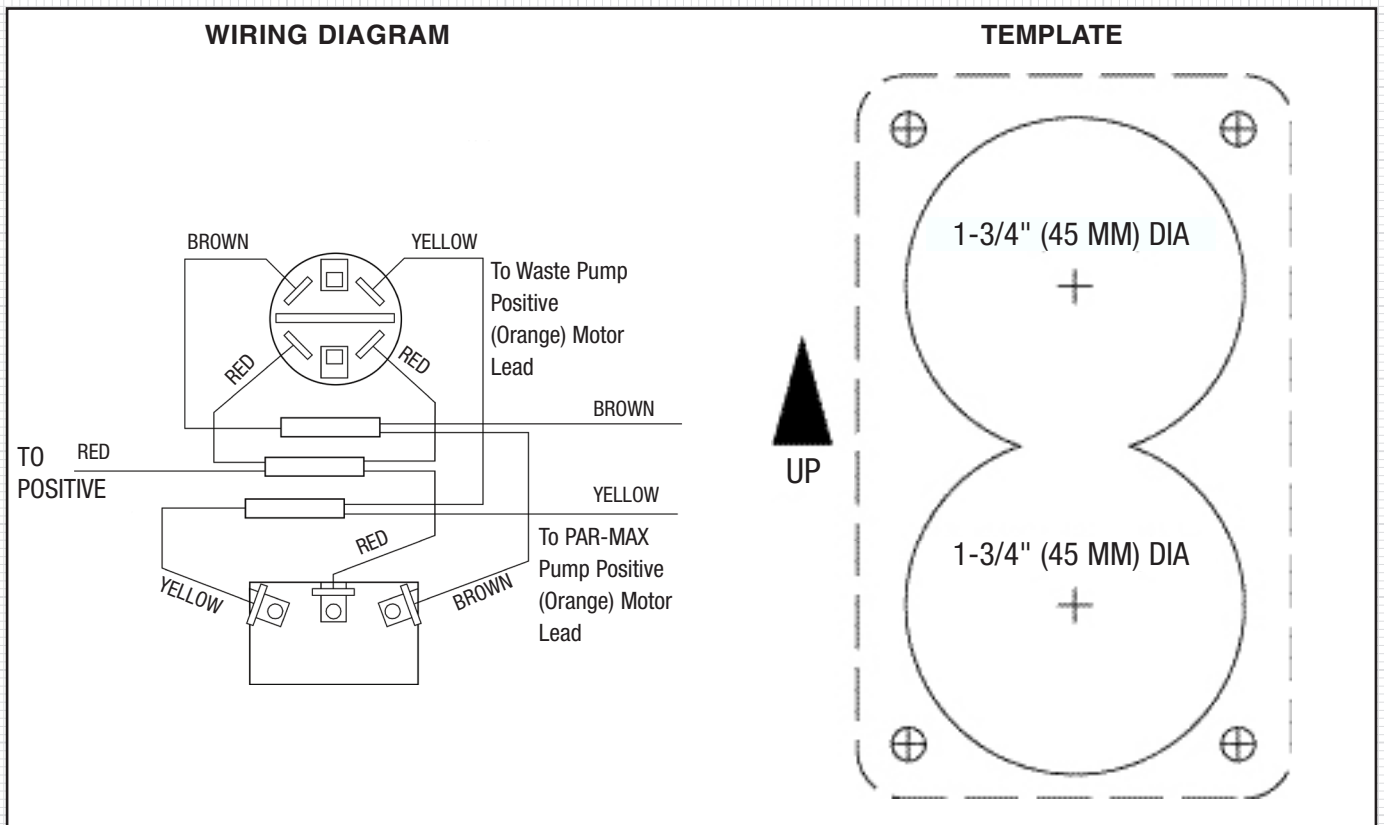

⚠ WARNING



Flood hazard. If toilet is plumbed to an overboard discharge, close the discharge seacock prior to disassembling toilet. Failure to do so can result in flooding which can cause loss of property and life.

Wire the switch panel to the PAR-MAX rinse pump and toilet waste pump as per the wiring diagram. The brown lead from the control panel connects with the waste pump orange (positive) motor lead. The yellow lead from the control panel connects with the PAR-MAX rinse water pump orange (positive) motor lead.

The black motor lead from each pump must be connected to battery negative. Select a location for the switch panel that is convenient to the toilet user and will also allow access to run the wires from the switch panel to both the toilet's waste pump motor and the PAR-MAX pump as well as from the electrical power source to the switch panel. To install the switch panel, drill two 1-3/4" (45 mm) diameter holes (slightly over-lapping) through the selected switch mounting surface per the attached template. Ensure the template is oriented correctly because it is not symmetrical. Also, drill four appropriate sized holes for the fasteners selected to secure the switch panel to its mounting surface.

WASTE PUMP SERVICE

The Jabsco Quiet-Flush Toilet does not require routine maintenance other than occasional cleaning to maintain a hygienic sanitary condition. Clean toilet with mild non-abrasive cleaners without strong aromatics. Cleaners having high concentrations of aromatics such as pine scented concentrated cleaners and strongly scented degreaser concentrates can cause the pump's seal to swell and may contribute to a premature seal leak. The toilet has no wearing parts that need periodic replacement other than the shaft seal which, under normal conditions, should provide several years of service before needing replacement. The seal only requires replacement if signs of leakage are noticed around the base and rear of the toilet china bowl.

NOTICE: Before performing any service, turn off the electrical power to the toilet and rinse water pump. Take precaution to ensure it is not turned on until the service is complete. Also, pump all water from the toilet bowl and if connected to an overboard discharge, close the discharge seacock.

To replace the shaft seal, remove the two toilet hold-down screw caps and remove the hold-down screw nuts. Carefully lift the toilet up and away from the bulkhead at its rear. Remove the pump assembly by removing the four screws with lock washers that secure it to the plastic toilet base. Carefully slide the pump assembly from the base ensuring the macerator housing also slides out of the base with the pump. The pump chopper will engage the macerator housing and it may be necessary to gently tap the chopper against the macerator housing to free it from the base.

Prevent the motor shaft from turning by inserting a screwdriver in the shaft slot at the rear of the motor and remove the self locking nut. Remove the chopper and macerator housing from the motor shaft. Remove the O-ring from the O-ring groove around the outer diameter of the seal housing. With an allen wrench, loosen the centrifugal impeller set screw and slide the impeller off the shaft. Remove the two screws that secure the seal housing to the motor and slide the housing off the motor shaft. Remove the two seal washers from under the head of each of the two seal housing retainer screws. With a pair of needle nose pliers, grasp the shaft seal and pull it from the seal housing. Clean all parts and inspect for damage.

Lubricate the OD of the new seal with a small amount of water and press it into the seal bore with the seal's lip facing the threaded end of the shaft.

Do not use the stainless steel star retaining washer supplied with the seal.

Lubricate the ID of the seal and the motor shaft with a small amount of water resistant grease. Ensure the slinger is properly positioned on the motor shaft next to the motor and slide the seal housing onto the motor shaft until it is against the motor end bell. Position a new plastic seal washer under the head of each of the flat head seal housing retainer screws and secure the seal housing to the motor. Slide the centrifugal impeller on the motor shaft positioning it about 1/32" (1 mm) from the seal housing and secure it to the shaft with the set screw. Rotate the impeller to ensure it does not rub on the seal housing.

Slide the macerator housing over the motor shaft. Place the chopper on the shaft with the tab on the flat of the shaft. Install the self locking nut and tighten firmly while holding the motor shaft at the rear of the motor. Position a new O-ring in the seal housing O-ring groove (it may be retained in the groove with a small amount of grease). Slide the pump assembly into the toilet base ensuring the macerator housing is properly positioned within the base.

The cut-out in the side of the macerator housing must align with the discharge port in the base (the macerator housing is keyed so it will only go in when properly positioned). Ensuring the O-ring is still properly positioned in the O-ring groove in the seal housing, place the pump assembly against the base and secure it in place with the four screws and lock washers.

Carefully lift the toilet and position over the two hold-down screws using caution not to chip or break the china. Secure the toilet down with the hold-down nuts and washers ensuring the plastic washer is next to the china.

Do not overtighten hold-down nuts.

EXPLODED VIEW

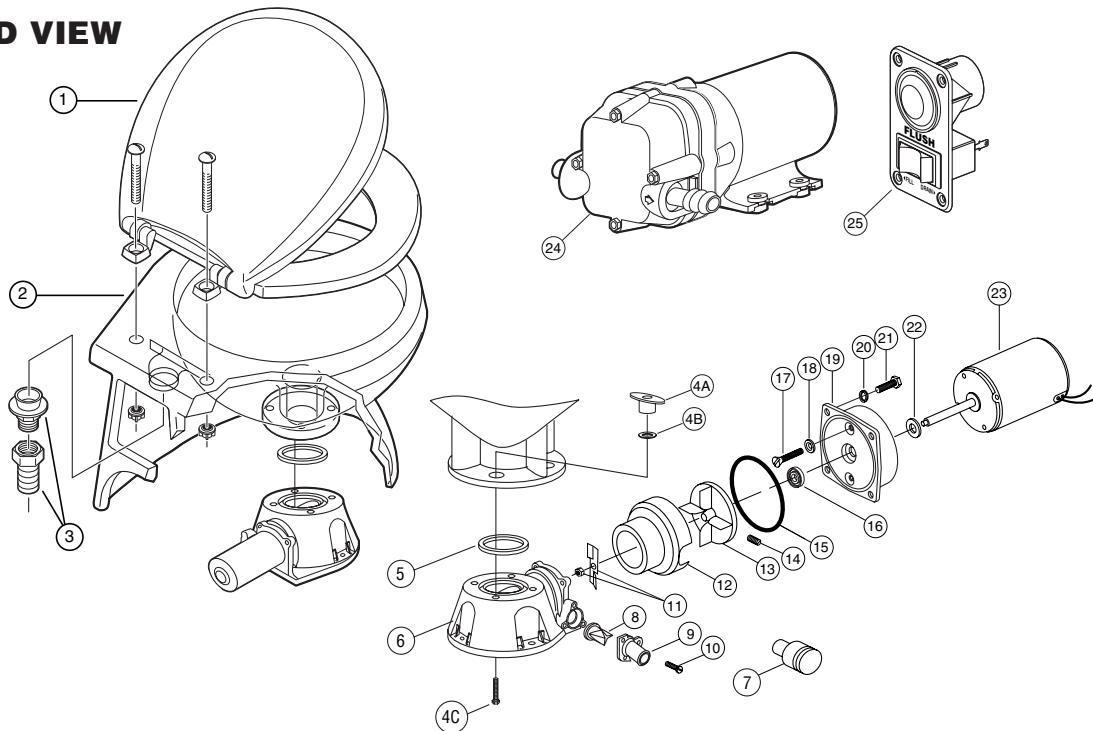

PARTS LIST

Key	Description	Qty. Req.	Part Number	Key	Description	Qty. Req.	Part Number
1	Seat & Cover	1	37078-1000	16	Seal†	1	1040-0000
2	Bowl, Compact Size, White	1	37076-0010	17	Screw†	2	91010-0144
	Bowl, Standard Size, White	1	37076-1010	18	Washer, Plastic*†	2	35445-0000
	Bowl, Compact Size, Bone	1	37076-2010	19	Seal Housing†	1	37043-1000
	Bowl, Standard Size, Bone	1	37076-3010	20	Lock Washer #10, Stainless Steel†	4	
3	Bowl Spud and 3/4" barbed adaptor	1	18753-0609	21	Screw†	4	91027-0011
4	Bowl Installation Hardware	1	18753-0604	22	Slinger†	1	6342-0000
4A	Tee Nut**	4		23	Motor - 12 Volt EMC†	1	18753-0582
4B	Washer, Plastic**	4			Motor - 24 Volt EMC†	1	18753-0583
4C	Socket Head Screw**	4		24	PAR-MAX 4 Rinse Water Pump		
5	Gasket*	1	37017-0000		12 Volt EMC	1	30631-1092
6	Base Assembly**	1	37004-1000		24 Volt EMC	1	30631-1094
7	1-1/2" Adaptor, Discharge Port	1	98023-0080	25	Switch Panel	1	37047-1000
8	Joker Valve* **	1	44106-1000		Service Kit	1	90197-0000
9	1" Discharge Port**	1	37077-1000		Waste Pump Assembly		
10	Screw**	3	96050-0568		12 Volt EMC	1	37072-0092
11	Chopper Plate with Lock Nut†	1	37056-1000		24 Volt EMC	1	37072-0094
12	Macerator Housing†	1	37014-0000				
13	Centrifugal Impeller†	1	37006-0000				
14	Set Screw†	1	18753-0492				
15	O-ring*†	1	43990-0066				

* Parts supplied with Service Kit.

** Parts included with base 37004-1000.

† Parts included in Waste Pump Assembly

PAR-MAX SERVICE INSTRUCTIONS

The PAR-MAX rinse water supply pump needs no periodic maintenance for proper performance. The only time service work should need to be performed on the pump is if it should begin to leak water, suddenly delivers less water than normal or should stop pumping altogether. Should the pump begin to leak water, it will be necessary to replace the diaphragm. If the pump delivers a reduced rate of flow from normal or stops pumping altogether, it will be necessary to either remove debris from the pump's flapper valves or replace the valve cage assembly.

NOTICE: Before performing any service, turn off the electrical power to the toilet and rinse water pump. Take precaution to ensure it is not turned on until service is complete. Close the inlet fitting seacock.

It is generally easiest to remove the pump from its installed position so that the service can be performed on a work bench. To do this, disconnect the electrical wires from the motor wire leads. Push the port retainer clips back toward the pump motor and pull the port fittings from the port sockets. Unscrew the four pump mounting fasteners and remove the pump to a location where it can be disassembled without losing any of the pump components.

Loosen the four 5/16" hex (slotted) machine screws in the pump body and remove the body from the motor and wobble plate housing (use care to not drop and lose the port retainer clips and body retaining screws and washers). The valve cage will now be exposed which can be easily lifted off the diaphragm. Inspect the four outer inlet valves and central discharge valve to ensure they seat smoothly against the valve cage.

Lift the outer edges of each valve to make certain there is no debris lodged under any valve. If there is debris lodged under any of the valves, it will cause a diminished flow rate or loss of flow entirely. If the valves do not seat smoothly against the valve cage, the valve cage assembly should be replaced. If the pump has been leaking, the diaphragm must be replaced. Remove the four phillips head diaphragm retainer screws and mushroom shaped diaphragm retainer caps. Remove the diaphragm and diaphragm housing from the motor and wobble plate housing. Inspect the wobble plate bearing to make certain it is not corroded and still rotates smoothly.

With the new diaphragm positioned in the diaphragm housing (ensure the raised sealing beads face outward away from the motor) hold it against the wobble plate with the four retaining cap holes aligned with the wobble plate sockets. Push each diaphragm retainer cap through the diaphragm and into the socket of the wobble plate. Secure each retaining cap to the wobble plate with a 1" phillips head retainer screw. Place the motor on its rear end bell and position the valve cage against the diaphragm ensuring each cavities seal groove is seated on its sealing bead molded into the diaphragm.

Ensure the O-ring seal that separates the pumps intake chamber from the discharge chamber is properly seated in the ID of the raised lip around the central discharge valve. While holding the port retainer clips in their slide grooves in the pump body, position the body on the diaphragm and inside the wobble plate housing. Secure the pump body to the wobble plate housing with the four 2-1/4" machine screws and flat washers.

Reinstall the pump to its mounting surface with four fasteners through the rubber grommets. Ensure the sealing O-ring is properly positioned on each port fitting and, with the retaining clips slid back, push each port fitting into its respective socket.

Slide each port retainer clip forward until it snaps securely into its seated position. Reconnect the orange motor lead to the positive supply wire and the black motor lead to the negative wire.

Ensure the inlet seacock is open before restoring power to and operating the toilet.

ONE YEAR LIMITED WARRANTY

A. LIMITED WARRANTY: JABSCO warrants that at the time of shipment, the products manufactured by JABSCO and sold hereunder shall be in conformity with applicable written specifications and descriptions referred to or set forth herein, free from defects in material and workmanship, merchantable, and suitable for a particular purpose, provided such is implied by State law under the circumstances of this sale.

B. WARRANTY ADJUSTMENT:

1. JABSCO agrees to repair or furnish a replacement for, but not to remove or install, any product or component thereof which, within one (1) year from date of purchase, shall upon test and examination by JABSCO prove defective within the above warranty. Receipt verifying purchase date is required to obtain adjustment.
2. Buyer shall notify JABSCO of any defect within this warranty no later than ninety (90) days after the defect is discovered.
3. No product will be accepted for return or replacement without the prior written authorization of JABSCO. Upon such authorization, and in accordance with instructions from JABSCO, the product will be returned to JABSCO, shipping charges prepaid by Buyer. Products returned to JABSCO will be addressed as follows:

JABSCO
Cape Ann Industrial Park
Gloucester, MA 01930

Or to such alternate locations as may be designated on the product, its container, or this sheet. Repair or replacement made under this warranty will be shipped prepaid to Buyer.

C. EXCLUSIONS FROM WARRANTY AND LIMITATION OF LIABILITY:

1. The foregoing warranty is limited solely as set forth herein and applies only for the period designated above.
2. JABSCO SHALL NOT BE LIABLE FOR ANY LOSS, DAMAGE, SPECIAL OR CONSEQUENTIAL DAMAGE OF ANY KIND, WHETHER BASED UPON WARRANTY, CONTRACT, NEGLIGENCE, OR STRICT LIABILITY ARISING IN CONNECTION WITH THE SALE, USE, OR REPAIR OF THE PRODUCT.
3. THE MAXIMUM LIABILITY OF JABSCO IN CONNECTION WITH THIS WARRANTY SHALL NOT IN ANY CASE EXCEED THE CONTRACT PRICE FOR THE PRODUCT CLAIMED TO BE DEFECTIVE OR UNSUITABLE.
4. This warranty does not extend to any product manufactured by JABSCO which has been subjected to misuse, neglect, accident, improper installation, or use in violation of instructions furnished by JABSCO.

5. This warranty does not extend to or apply to any unit which has been repaired or altered at any place other than JABSCO's factory, or by persons not expressly approved by JABSCO, nor to any unit the serial number, model number, or identification of which has been removed, defaced or changed.
6. Components manufactured by any supplier other than JABSCO shall bear only that warranty made by the manufacturer of that product.
7. This warranty applies to products defined as "consumer products" by the Consumer Product Warranties Act as from time to time amended.

D. CONSUMER RIGHTS: This warranty gives you specific legal rights, and you may have other rights which vary from state to state. Some states do not allow exclusion or limitation of damages.

STANDARD WARRANTY: If the products manufactured and sold hereunder are not Consumer Products, the warranty extended to Buyer shall be as set forth in subparagraphs (A), (B), and (C), **EXCEPT THAT ALL EXPRESS OR IMPLIED WARRANTIES OR MERCHANTABILITY OR SUITABILITY FOR ANY PARTICULAR PURPOSE ARE EXCLUDED.**

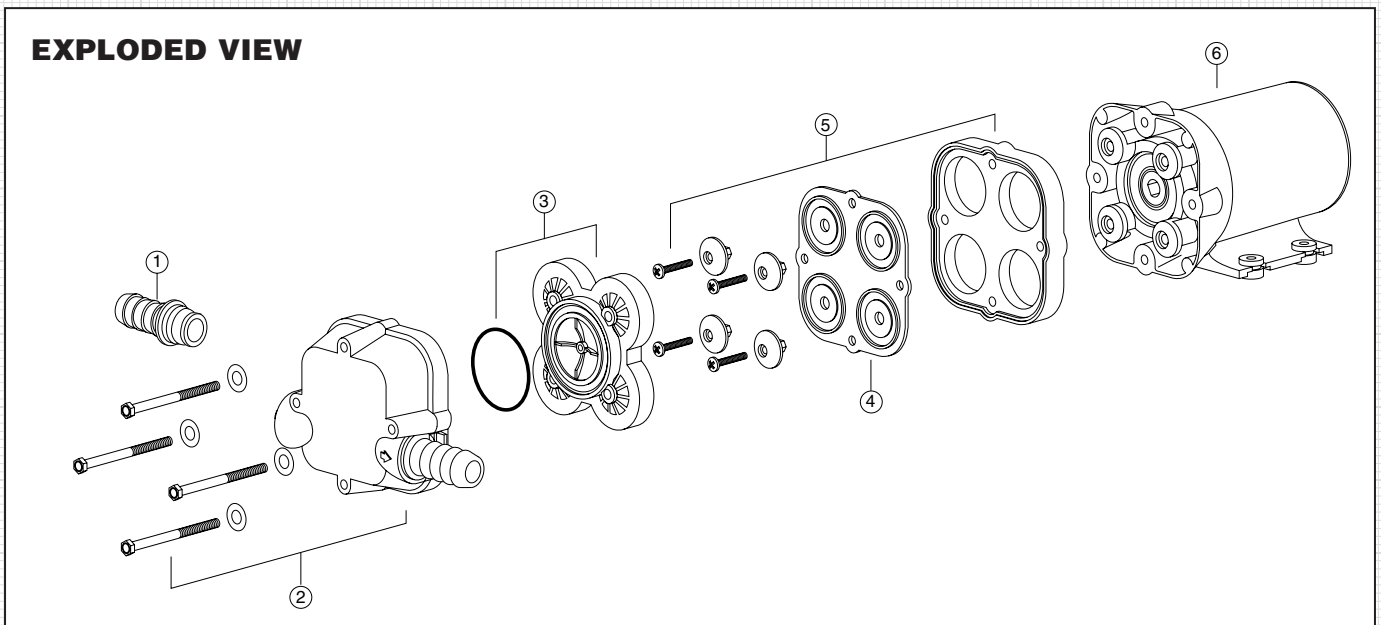

PARTS LIST

Key	Description	Qty. Req.	Part Number	Key	Description	Qty. Req.	Part Number
1	Port Kit (1 Pair)	1	30653-1004	6	Motor Kit 12 Vdc EMC	1	18753-0577
2	Body Kit	1	30608-1001		Motor Kit 24 Vdc EMC	1	18753-0578
3	Valve Cage / Valve Assy.	1	30613-1001		Motor / Pump Assy. 12 Vdc EMC	1	30631-1012
4	Diaphragm Kit	1	30617-1000		Motor / Pump Assy. 24 Vdc EMC	1	30631-1024
5	Diaphragm Housing & Retainer Cap Kit	1	30682-1000				

DIMENSIONAL DRAWINGS Inches (Millimeters)

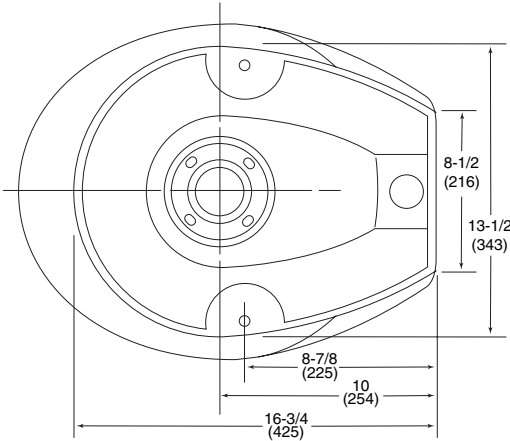
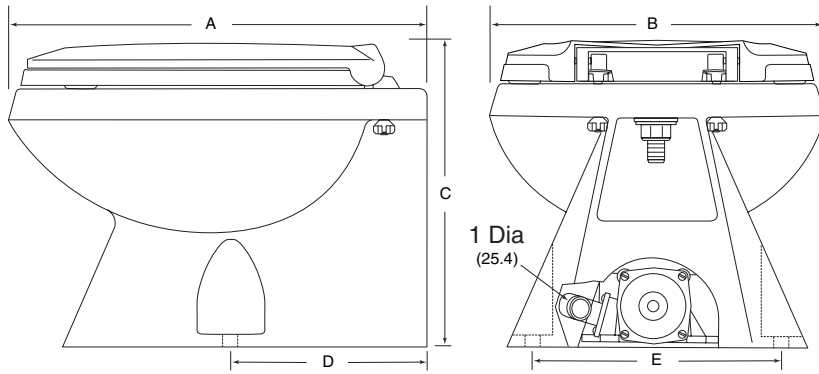

	Compact Size Bowl	Standard Size Bowl
A	19-3/16 (487)	19-3/16 (487)
B	15-1/2 (394)	15-1/2 (394)
C	14-1/4 (362)	17-1/4 (438)
D	8-7/8 (225)	8-7/8 (225)
E	11-13/16 (300)	11-13/16 (300)

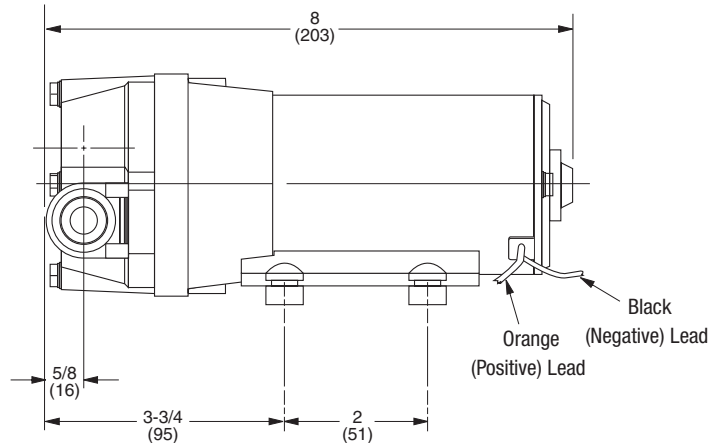
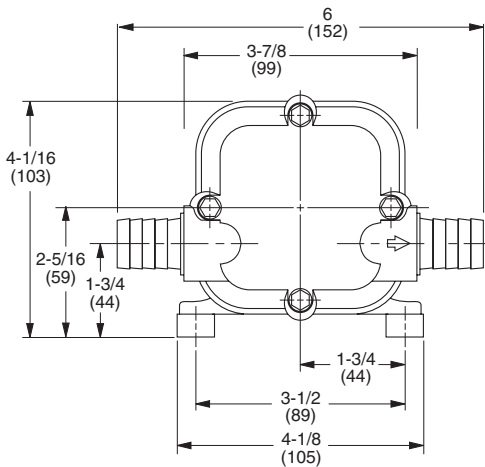

Engineered for life

www.jabscos.com

UK
ITT Industries
Bingley Road, Hoddesdon
Hertfordshire EN11 0BU
Tel: +44 (0) 1992 450145
Fax: +44 (0) 1992 467132

USA
ITT Corporation
Cape Ann Industrial Park
Gloucester, MA 01930
Tel: (978) 281-0440
Fax: (978) 283-2619

ITALY
Jabscos Marine Italia
Via Tommaseo, 6
20059 Vimercate, Milano
Tel: +39 039 685 2323
Fax: +39 039 666 307

GERMANY
Jabscos GmbH
Oststrasse 28
22844 Norderstedt
Tel: +49-40-53 53 73-0
Fax: +49-40-53 53 73-11

JAPAN
NHK Jabscos Company Ltd.
3-21-10, Shin-Yokohama
Kohoku-Ku, Yokohama, 222-0033
Tel: +81-045-475-8906
Fax: +81-045-477-1162

Warranty: All products of the company are sold, and all services of the company are offered subject to the company's warranty and terms of sale, copies of which will be furnished upon request. Details correct at time of printing. We reserve the right to change specifications without prior notice.

© Copyright 2009 ITT Industries, Registered England No. 81415, registered office: Jays Close Viabes Estate, Basingstoke, Hants, RG22 4BA