



# QUIET - FLUSH ELECTRIC TOILET CONVERSION FEATURES

- Very quiet flush cycle - like a household toilet
- Converts all Jabsco, Par manual toilets and early electric toilets to the new Quiet-Flush System
- Also converts Groco HC, HE & HF; Raritan PH, Cricket & Compact; Sealand (Mansfield) 750 to 752 series and all Wilcox Crittenden toilets
- Single button flush actuator - with dual function water level control switch
- Can be plumbed to any pressurized water system that can provide a 3-1/2 GPM (13.5 LPM) flow rate
- Water control solenoid valve with anti-siphon breaker to prevent contamination of potable water supply
- High capacity waste macerator and bowl discharge pump

## SPECIFICATIONS

PORTS	Inlet 3/4" Hose Barb Outlet 1" Hose Barb
MOTOR & SWITCH	Meet U.S.C.G. Regulation 183.410 and ISO 8846 MARINE for Ignition Protection.
WATER CONSUMPTION	1-2 Quarts (Litres) per Flush

## VARIATIONS AVAILABLE

MODEL NO.	DESCRIPTION
37055-0092*	Toilet Conversion, 12 Volt EMC
37055-0094*	Toilet Conversion, 24 Volt EMC

\*This model is  Marked and complies with EN50081-1 for suppression of electro-magnetic interference.

## OPERATION

The Quiet-Flush Toilet Conversion provides both quiet operation and user control of water levels in the toilet bowl. A single large push button switch provides a simple flush mode by activating both the rinse water supply and the macerator discharge pump simultaneously. An additional rocker switch offers independent control of the rinse water supply and discharge pump separately so the bowl water level can be easily raised or lowered by the user. This provides a method of minimizing water use, when desired, as well as a means of raising the water level in the bowl when appropriate for user comfort. It also allows for complete evacuation of the bowl water while underway in rough sea conditions.



## INSTALLATION

### PLUMBING

The 37055 Series Quiet-Flush Toilet Conversion can be plumbed to any pressurized water system that can provide a minimum of 3-1/2 GPM (13.5 LPM). This may be a fresh water system including the vessel's potable water system or a washdown system utilizing either fresh or salt water. However, it must be connected to a pressurized system that normally remains on at all times while the vessel is in use.

Before beginning the conversion, close all seacocks connected with the toilet's plumbing system and take precaution to ensure they remain closed until the conversion is complete. If the toilet being converted is an electric toilet, disconnect the electrical power to the toilet and take precaution to ensure it is not restored until the conversion is complete.

Disconnect both inlet and discharge hoses from the old toilet and remove the toilet from its mounting surface. Remove the hose connected to the back of the toilet's china bowl and remove the china bowl and seat & lid assembly from the old toilet base assembly. Ensure the bottom surface of the china bowl is clean. The waste pump can be oriented in any of the possible mounting positions that provides the best clearance from surrounding obstructions but is generally best positioned so it points to the rear of the toilet bowl. The four 6mm machine screws must be secured into the base to form mounting studs to attach the china bowl. Place one starlock washer on each of the phillips head machine screws and a 6mm hex nut in each of the hex shaped pockets on the top surface of the base. From the underside of the base, screw one machine screw into each of the nuts in the hex shaped pockets and tighten it to form bowl mounting studs. Position the square section O-ring

in the O-ring groove on the top of the base and place the china bowl on the base in the desired orientation relative to the pump assembly. Place one plastic washer (to protect the china), then one stainless steel washer on each machine screw and attach the remaining hex nuts to secure the bowl to the base. Cap each machine screw and nut with a white decorative nut cap.

Position the toilet assembly in its intended installed position. When locating the toilet, ensure there is adequate clearance above and to the rear of the bowl so the seat and lid assembly can rotate slightly past vertical and will remain up when lifted. Once the exact position for the toilet has been determined, mark the location of the three base attachment holes on the toilet mounting surface. Determine the best toilet attachment method using 1/4" (6mm) fasteners (either machine screws for through bolting or lag screws for topside attachment) and drill the appropriate size holes for the fasteners being used. If securing the toilet with lag screws into a plywood underlayment below fiberglass, be sure to drill a hole through just the fiberglass layer large enough to allow clearance for the screw threads and shank to avoid cracking the fiberglass.

To make the water connection, shut off the water system pump and open one of the systems faucets or fixtures to drain the pressure from the system. Select an appropriate tee type fitting that can be installed in the existing pressurized water system and will provide a 1/2" (13mm) hose barb to feed water to the toilet. Install the tee fitting at a location on the pressurized water system that provides convenient connection to the toilet's solenoid valve/siphon breaker assembly. If the toilet is being connected to the vessel's fresh water system and the vessel may be connected to an unregulated city water supply, it is recommended that a valve be installed in the toilet water supply line ahead of the solenoid valve/siphon breaker to regulate the flow rate of incoming pressurized city water.

The solenoid valve/siphon breaker should be positioned a minimum of six inches above the hose connection at the back of the toilet bowl (at all angles of heel and trim) and located as close to the toilet as possible. It should be located where an occasional drop or two of water from the siphon breaker will not adversely affect nearby equipment or supplies. It must be installed in a vertical position with the hose barb connections pointing down. The solenoid valve/siphon breaker bracket should be secured to a solid mounting surface with four screws. If the valve assembly is attached to a wood surface, 3/8" (10mm) long screws are generally adequate to support the weight of the valve assembly. If desired, the valve assembly may be installed inside a cabinet or locker to conceal it from view of the vessel's occupants. To provide a clean sanitary appearance inside the head area, a six foot section of smooth white hose is provided with the toilet to connect the toilet bowl spud fitting to the siphon breaker outlet hose barb.

The solenoid valve inlet hose barb is then connected with 1/2" (13mm) reinforced vinyl hose suitable for pressurized water to the tee fitting installed in the water system line. All

pressurized water system connections should be secured with stainless steel band type hose clamps. The 3/4" hose connecting the siphon breaker to the bowl should be secured with a band clamp at the siphon breaker to prevent it from being accidentally dislodged but generally does not need a hose clamp to secure it to the bowl spud fitting unless desired for added security.

The discharge port includes a 1" (25mm) hose barb and should be plumbed with 1" (25mm) hose to an on board holding tank or, if appropriate, to an overboard discharge through hull. A 1" (25mm) to 1-1/2" (38mm) barbed hose adaptor is provided to adapt a 1" (25mm) discharge hose to 1-1/2" (38mm) hose, if desired. The discharge plumbing should be kept as short as possible and bends in the discharge hose should be kept to a minimum. To retain water in the bowl, the discharge hose should be looped upward about eight to ten inches above the base of the toilet and as near to the toilet as can be practically accomplished without creating an unsightly plumbing situation.

	<b>WARNING</b> Flood hazard. If toilet is installed below the waterline, it must be installed with a properly positioned vented loop in the discharge hose. Failure to do so can result in flooding which can cause loss of property and life.
---	--

If the toilet is below the water line and is plumbed to an overboard discharge through hull, the discharge plumbing must include a vented loop positioned so it remains above the water line at all angles of heel and trim. Total discharge head should not exceed 4 feet (1.2M).

## ELECTRICAL

The electrical wiring should be independent of all other accessories. It should be made with marine grade copper stranded wire of the gauge specified in the electrical specifications chart. Make all wire connections with mechanical locking type connectors (crimp type butt connectors and terminals). Ensure the circuit is protected by a proper sized fuse or circuit breaker determined from

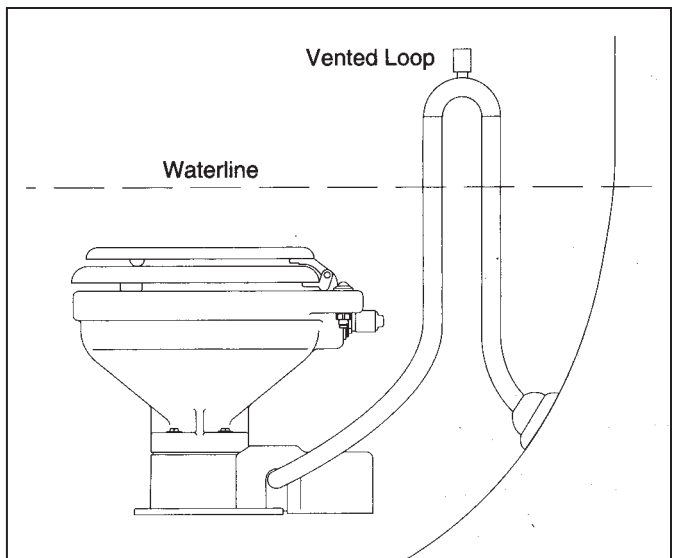

the electrical specifications chart. Secure all wires to a solid surface approximately every eighteen inches (1/2M) along their entire length of run.

Wire the switch panel to the solenoid valve/siphon breaker and toilet pump assembly as per the following wiring diagram. Connect the brown lead from the panel to the waste pump positive (orange) lead. Connect the black waste pump motor lead to battery negative. Connect the yellow lead from the panel to a solenoid valve terminal. Connect the remaining solenoid valve terminal to battery negative. The solenoid valve is not polarity sensitive.

Select a location for the switch panel that is convenient to the toilet user and will also allow access to run the wires from the switch panel to both the toilet's motor and the solenoid valve/siphon breaker as well as from the electrical power source to the switch panel. To install the

switch panel, drill two 1-3/4" (45mm) diameter holes (slightly over-lapping) through the selected switch mounting surface per the attached template. Ensure the template is oriented correctly because it is not symmetrical. Also, drill four appropriate sized holes for the fasteners selected to secure the switch panel to its mounting surface.

### SERVICE

The Jabsco Quiet-Flush Toilet does not require routine maintenance other than occasional cleaning to maintain a hygienic sanitary condition. Clean toilet with mild nonabrasive cleaners without strong aromatics. Cleaners having high concentrations of aromatics such as pine scented concentrated cleaners and strongly scented degreaser concentrates can cause the pump's seal to swell and may contribute to a premature seal leak.

### ELECTRICAL SPECIFICATIONS

Voltage	Amp Draw	Fuse Size	Wire Size Per Feet Of Run*				
			0'-10'	10'-15'	15'-25'	25'-40'	40'-60'
12 Vdc	10	25	#16	#14	#12	#10	#8
24 Vdc	5	15	#16	#16	#16	#14	#12

\* Length of run is total distance from power source to product and back to ground.

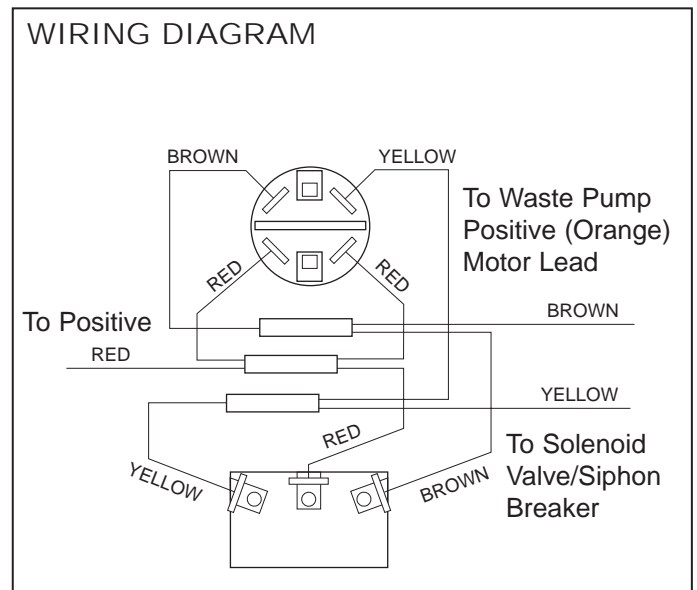
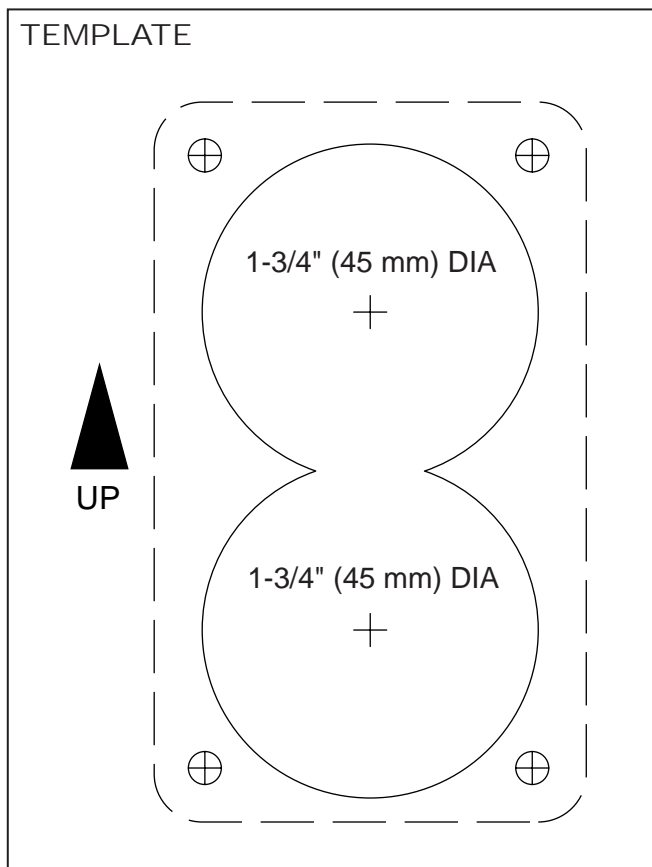

The toilet has no wearing parts that need periodic replacement other than the shaft seal which, under normal conditions, should provide several years of service before needing replacement. The seal only requires replacement if signs of leakage are noticed under the seal housing positioned between the motor and toilet base assembly.



**WARNING** Flood hazard. If toilet is plumbed to an overboard discharge, close the discharge seacock prior to disassembling toilet. Failure to do so can result in flooding which can cause loss of property and life.

Notice: Before performing any service, disconnect the power supply to the toilet and take precaution to ensure it is not reconnected until the service is complete. Also, pump all water from the toilet bowl and if connected to an overboard discharge, close the discharge seacock.

To replace the shaft seal, snap off the white motor cover and remove the pump assembly by removing the four screws with lock washers that secure it to the toilet base. Carefully slide the pump assembly from the base ensuring the macerator housing also slides out of the base with the pump.

The pump chopper will engage the macerator housing and it may be necessary to gently tap the chopper against the macerator housing to free it from the base.

Prevent the motor shaft from turning by inserting a screwdriver in the shaft slot at the rear of the motor and unscrew the nut retaining the chopper blade. Remove the chopper and macerator housing from the motor shaft. Remove the O-ring from the O-ring groove around the outer diameter of the seal housing. With an allen wrench, loosen the centrifugal impeller set screw and slide the impeller off the shaft. Remove the two screws that secure the seal housing to the motor and slide the housing off the motor shaft. Remove the two seal washers from under the head of each of the two seal housing retainer screws. With a pair of needle nose pliers grasp the shaft seal and pull it from the seal housing. Clean all parts and inspect for damage.

Lubricate the OD of the new seal with a small amount of water and press it into the seal bore with the seal's lip facing the threaded end of the shaft. Do not use the stainless steel star retaining washer supplied with the seal. Lubricate the ID of the seal and the motor shaft with a small amount of water resistant grease. Ensure the slinger is properly positioned on the motor shaft next to the motor and slide the seal housing onto the motor shaft until it is against the motor end bell. Position a new plastic seal washer under the head of each of the flat head seal housing retainer screws and secure the seal housing to the motor. Slide the centrifugal impeller on the motor shaft positioning it about 1/32" (1mm) from the seal housing and secure it to the shaft with the set screw. Rotate the impeller to ensure it does not rub on the seal housing.

Slide the macerator housing over the motor shaft, position the SS chopper blade on the end of the shaft, then place the nut on the shaft and tighten holding the shaft slot at the rear of the motor. Position a new O-ring in the seal housing O-ring groove (it may be retained in the groove with a small amount of grease). Slide the pump assembly into the toilet base ensuring the macerator housing is properly positioned within the base. The cut-out in the side of the macerator housing must align with the discharge port in the base (the macerator housing is keyed so it will only go in when properly positioned). Ensuring the O-ring is still properly positioned in the O-ring groove in the seal housing, place the pump assembly against the base and secure it in place with the four screws and lock washers. Replace the white motor cover by snapping it down over the pump motor.

# EXPLODED VIEW

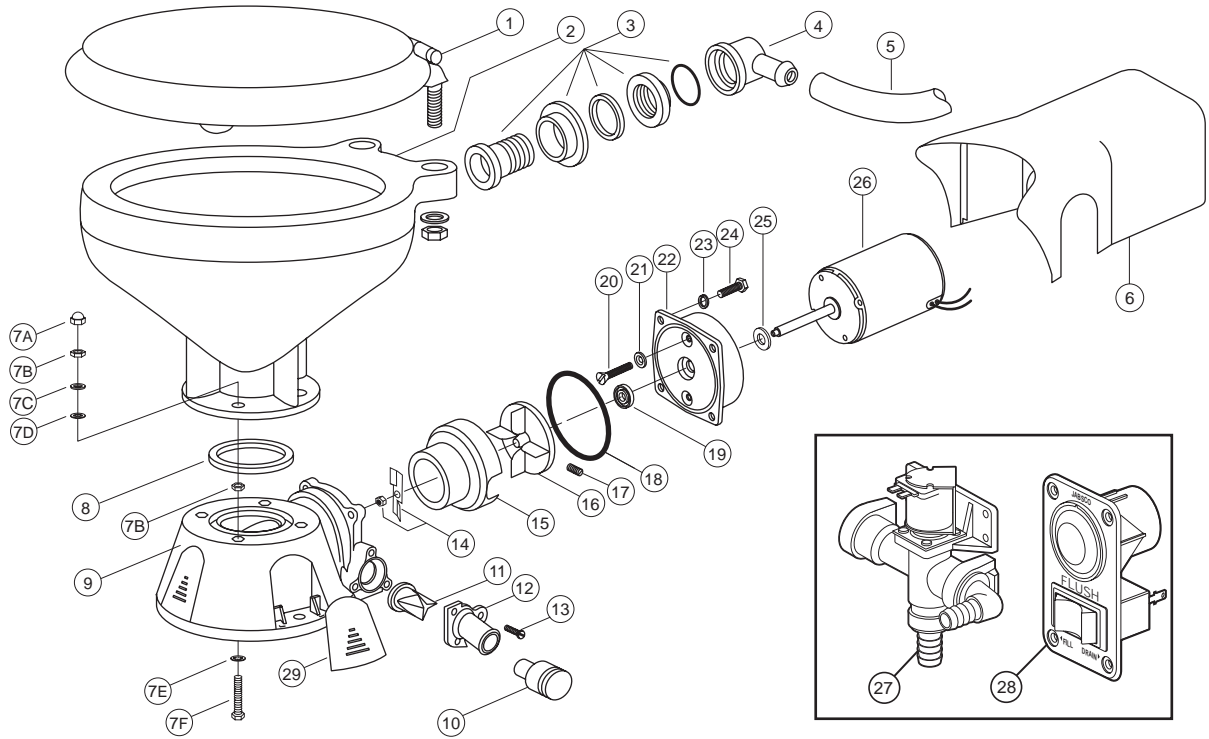

## PARTS LIST

Key	Description	Qty. Req.	Part Number
1	Seat & Cover, Compact Size	1	18753-0437
	Seat & Cover, Household Size	1	18753-0438
2	Bowl, Compact Size	1	59127-7002
	Bowl, Household Size	1	18753-0060
3 & 4	Bowl Spud & Intake Elbow & O-ring	1	29048-0000
5	Hose, 6 feet	1	29035-1031
6	Motor Cover †	1	37044-6000
7	Bowl Installation Hardware	1	18753-0637
7A	Nut Cap**	4	
7B	Hex Nut** (Two places)	8	
7C	Washer, Stainless Steel**	4	
7D	Washer, Plastic**	4	
7E	Washer, Starlock**	4	
7F	Phillips Head Screw**	4	
8	Bowl O-Ring Seal	1	44101-1000
9	Base Assembly**	1	37004-1000
10	1-1/2" Adaptor, Discharge Port	1	98023-0080
11	Joker Valve* **	1	44106-1000
12	1" Discharge Port**	1	44107-1000
13	Screw**	3	96050-0568
14	Chopper Plate with Lock Nut †	1	37056-1000
15	Macerator Housing †	1	37014-0000
16	Centrifugal Impeller †	1	37006-0000

Key	Description	Qty. Req.	Part Number
17	Set Screw †	1	91084-0320
18	O-ring* †	1	43990-0066
19	Seal* †	1	1040-0000
20	Screw †	2	91010-0144
21	Washer, Plastic* †	2	35445-0000
22	Seal Housing †	1	37043-1000
23	Lock Washer #10, Stainless Steel †	4	
24	Screw †	4	91027-0011
25	Slinger †	1	6342-0000
26	Motors:		
	Motor - 12 Volt EMC †	1	18753-0554
	Motor - 24 Volt EMC †	1	18753-0555
27	Solenoid Valve & Siphon Breaker 12 Volt	1	37038-1012
28	Switch Panel	1	37047-1000
29	Screw Covers (3/kit) Service Kit	1	37003-1000
	Motor & Pump Assembly		90197-0000
	12 Volt EMC		37072-0092
	24 Volt EMC		37072-0094

\* Parts Supplied with Service Kit.

\*\* Parts included with base 37004-1000.

† Parts included in Motor & Pump Assembly.

**DIMENSIONAL DRAWING**  
Inches (Millimetres)

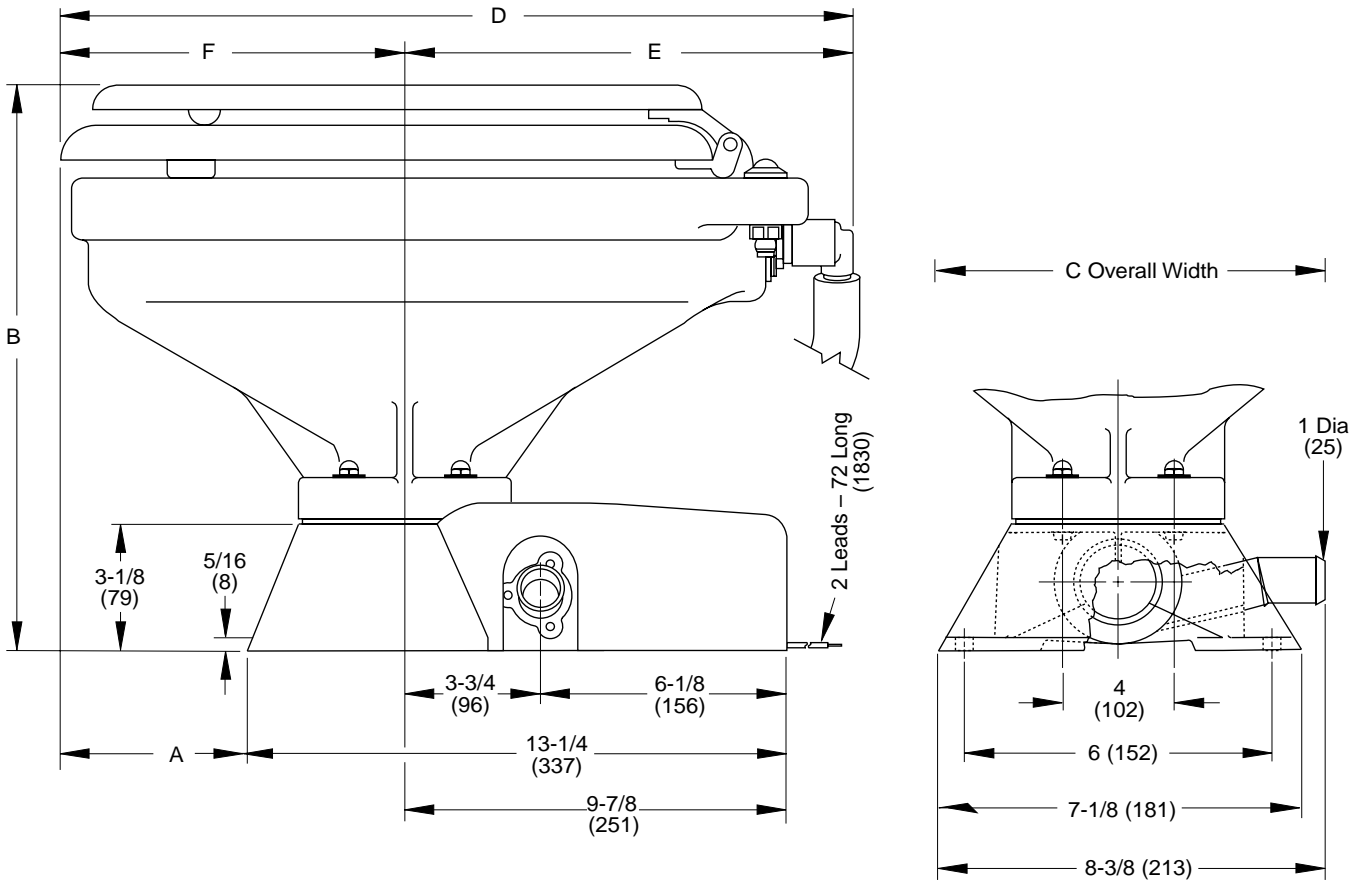

	A	B	C	D	E	F
Compact Size Bowl	2-7/8 (74)	14-1/8 (359)	13-1/8 (333)	16-1/2 (419)	10 (254)	6-1/2 (165)
Household Size Bowl	4-3/8 (112)	14-1/8 (359)	14-3/4 (375)	19-3/4 (502)	10-3/4 (273)	9 (229)

**Jabsco**



**ITT Industries**  
*Engineered for life*

THE PRODUCTS DESCRIBED HEREIN ARE SUBJECT TO THE JABSCO ONE YEAR LIMITED WARRANTY, WHICH IS AVAILABLE FOR YOUR INSPECTION UPON REQUEST.

U.S.A.  
Jabsco  
Cape Ann Industrial Park  
Gloucester, MA 01930  
Tel: 978.281.0440  
Fax: 978.283.2619

UNITED KINGDOM  
Jabsco  
Bingley Road, Hoddesdon  
Hertfordshire EN11 OBU  
Tel: +44 (0) 1992 450145  
Fax: +44 (0) 1992 467132

CANADA  
Fluid Products Canada  
55 Royal Road  
Guelph, Ontario N1H 1T1  
Tel: (519) 821.1900  
Fax: (519) 821.2569

JAPAN  
NHK Jabsco Company Ltd.  
3-21-10, Shin-Yokohama  
Kohoku-Ku, Yokohama, 222  
Tel: 045.475.8906  
Fax: 045.475.8908

GERMANY  
Jabsco GmbH  
Oststrasse 28  
22840 Norderstedt  
Tel: +49-40-53 43 73 -0  
Fax: +49-40-53 53 73 -11