



Model 31801 and 31800 Series 115 VAC INDUSTRIAL DIAPHRAGM PUMPS

INDUSTRIAL DIAPHRAGM PUMPS

FEATURES

- Run Dry Ability
- Self-Priming
- Thermal Overload Protected Motor
- Easy Installation
- Low Amp Draw
- Compact Size
- Quiet Running
- Snap-in Port Adapters
- Flow to 3 GPM/12 LPM
- **CE** Conforms to Electromagnetic Compatibility 89/336/EEC and Machinery Directive 89/392/EEC, EN50081-1

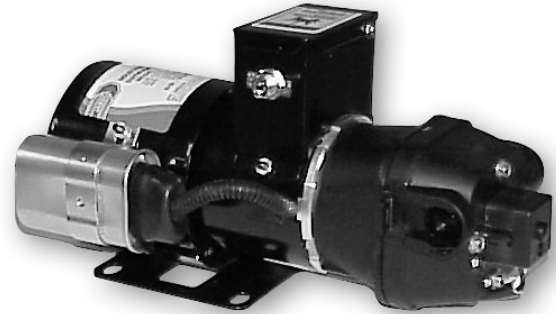

115 VAC INDUSTRIAL DIAPHRAGM PUMPS

SPECIFICATIONS

Materials	Pump Body	Glass-filled Polypropylene
	Diaphragm	Santoprene**
	Valves	Viton*or EPDM
Hardware	Stainless Steel	
Pump Design	Four Piston Diaphragm Type	
Pressure Switch	OFF at 40 psi ON at 25 psi	
Motor	AC Capacitor Start Induction Motor Fan Cooled, Sealed Ball Bearing Thermally Protected, 115VAC, 60Hz, 1ø 1.8 Amp, CSA, UL listed	
Continuous Duty Rating	25 psi (1.7 Bar) at 75°F (24°C) Ambient	
Ports	1/2" (13 mm) Hose Barb, Viton O-ring 1/2" Male Quest, EPDM O-ring	
Liquid Temperature	45°F (7°C) to 130°F (54°C) For use with Maximum 130°F (54°C) Water	
Viscosity	250 Centipoise Maximum	
Shipping Weight	12 lb (5.5 kg)	

⚠ CAUTION Not designed for outdoor use. Protect from direct splash and spray. Provide adequate ventilation.

APPLICATIONS

This pump provides excellent service where 115VAC 60hz single-phase power is required for operation. The AC capacitor start induction motor dramatically extends motor service life in applications where permanent magnet DC motors would require regular maintenance to replace worn motor brushes. This pump is the clear choice for continuous duty bulk transfer and recirculation applications.

Recommended for use with mild acids and bases compatible with the materials of construction. Typical applications include chemical feed, chemical transfer, coolant re-circulation, condensate removal, tank agitation, thermal mixing, filling, flushing, and washdown applications.

Pump will self-prime and can be mounted up to 9 feet above the liquid supply level. Pump can run dry without damage. Built-in pressure switch automatically turns pump off when discharge valve is closed. Snap-in ports for easy installation and maintenance. Optional 40 mesh inlet strainer mounts directly to suction port, and is available with 1/2" or 3/4" hose barb connection.

Not for use with gasoline or other flammable liquids. Not for use where flammable vapors are present. Pump must be properly grounded and protected from direct contact with water or other liquids.

CE Models	Flow GPM (LPM)	Voltage	Hertz and Phase	Pressure Switch	Valves	Diaphragm	AMP Draw @ 10 psi
31801-0115	3 (12)	115 VAC	60 Hz, ø1	40 PSI	Viton*	Santoprene**	1.1
31801-1305	3 (12)	115 VAC	60 Hz, ø1	40 PSI	EPDM	Santoprene**	1.1

* Viton is a registered trademark of DuPont Dow Elastomers L.L.C.

** Santoprene is a registered trademark of Monsanto.

OPERATING INSTRUCTIONS

	Explosion hazard. Do not pump gasoline or other flammable liquids. To do so can cause an explosion resulting in injury or death.
---	---

	Fire hazard. Wiring must comply with applicable electrical standards and include a properly sized fuse or circuit breaker. Improper wiring can cause a fire resulting in injury or death.
---	--

- 1. MOUNTING** JABSCO diaphragm pumps are self-priming and may be located in a dry location above or below the fluid supply. To vertically mount these units, it is best to do so with the motor on top. This will prevent fluid dripping on the motor in the event of a leak. Place pump on a solid surface and secure with four mounting screws being careful not to fully compress the rubber grommets which act as shock absorbers.
- 2. PLUMBING** 1/2" (13 mm) straight hose barb and 1/2" Quest straight port adapters are supplied to fit 1/2" inside diameter hose and 1/2" nut and ferrule installations. Note that Quest fittings are not designed to fit NPT tapered pipe fittings. Use adapter kit 20381-040J with 1/2" male pipe threads for NPT pipe installations. Use 1/2" ID hose and 1/2" fittings minimum. Use hose clamps to prevent air and liquid leaks. Connecting the pump directly to rigid pipe is not recommended. If rigid pipe is used, install a short piece of flexible hose between the pipe and pumphead to eliminate undue mechanical stress on the port fittings.

Use a 40 mesh strainer to prevent dirt and debris from entering the pumphead. Use inlet strainer 01740-012J for 1/2" hose barb connection or 01740-004J for 1/2" Quest connection. Periodically clean strainer screen.
- 3. ELECTRICAL CONNECTION** Place ON/OFF switch in OFF position before connecting to wall outlet. Pump must be connected to a properly grounded 3 prong electrical receptacle. Remove power from pump prior to disassemble or maintenance.
- 4. SELF-PRIMING** Pump is self-priming. Vertical dry lift capacity is 9 ft (2.7 m). Be sure suction piping is airtight or pump will not self-prime.
- 5. RUNNING DRY** Pump can run dry indefinitely without damage.
- 6. CHEMICAL COMPATIBILITY** Use with fluids compatible with the materials of construction. Consult factory for Chemical Compatibility Guide. Pump should be flushed with clean water or neutralizing solution after each use to prolong pump life.
- 7. TEMPERATURE** The maximum recommended fluid temperature is 130°F (54°C). Minimum recommended fluid temperature is 45°F (7°C).
- 8. VISCOSITY** The maximum recommended viscosity is 250 centipoise.
- 9. DUTY CYCLE** Motor and pump are designed for continuous operation in a 70°F (21°C) ambient air while pumping against 30 psi (2 bar) discharge pressure. Beyond these parameters an intermittent duty cycle is recommended to maximize pump life. In normal operation, motor case will get hot. Prolonged contact with motor could cause a burn on human skin.
- 10. START-UP AND OPERATION** Check level of fluid in supply tank. Open all valves in system. Switch pump

electrical circuit to ON position. Close discharge valve after flow becomes steady. Pump will shut off soon after closing valve. Pump is now ready for automatic operation. Pump will start when outlet valve is opened and stop when valve is closed. If pump is to be inoperative for a considerable period of time, flush pump with water, turn off electrical circuit to pump, and bleed system pressure by opening discharge valve. Do not allow liquid to freeze inside pumphead. Damage to pump may occur.

SERVICE INSTRUCTIONS

PUMP DISASSEMBLY

1. Remove power from pump. Open discharge valve to relieve system pressure.
2. Push port clips back and disconnect plumbing from pump.
3. Remove the four (4) pumphead screws.
4. Rotate pumphead until cam/bearing set screw is visible through drain notch.
5. Loosen cam/bearing set screw and slide pump off motor shaft.
6. Separate upper housing, lower housing, and check valve assembly as required.

PUMP ASSEMBLY

1. Install new outer piston in lower housing with piston tops pointing away from motor.
2. Install new diaphragm in lower housing with the molded O-ring seals facing away from motor.
3. Insert each inner piston through the diaphragm into outer piston.
4. Turn each piston until fully seated.
5. Secure cam/bearing assembly to outer pistons using 18 inch pounds (2.0 Nm) of torque.
6. Slide lower housing on motor shaft. Align set screw with motor shaft indentation.
7. Set screw MUST be positioned over shaft indentation and secured tightly.
8. Check that ferrules are installed in upper housing and O-ring is properly seated.
9. Install check valve assembly in upper housing and fit upper and lower housings together.
10. Align pumphead with motor and tighten four (4) screws evenly using 25 inch pounds (2.8 Nm) of torque.

⚠ CAUTION To reduce risk of shock, pull plug before servicing.

⚠ CAUTION To reduce risk of electric shock, connect only to a properly grounded, grounded-type receptacle.

⚠ CAUTION Pumps have thermal overload protected motors. The motor will automatically shut off if temperature rises due to an overload condition. If the motor shuts off in this manner, turn pump off. Restart pump after motor cools. If pump is not manually turned off after thermal shutdown, pump may turn on unexpectedly when motor cools.

SWITCH REPLACEMENT

1. Remove power from pump. Relieve system pressure. Disconnect inlet and outlet hoses.
2. Remove pressure switch cover and disconnect power leads from switch.
3. Remove switch and switch diaphragm from pump by removing two (2) switch mounting screws.
4. Replace switch diaphragm and switch. Reassemble in reverse order.
5. Do not over tighten switch mounting screws.

OPTIONAL PORT KITS

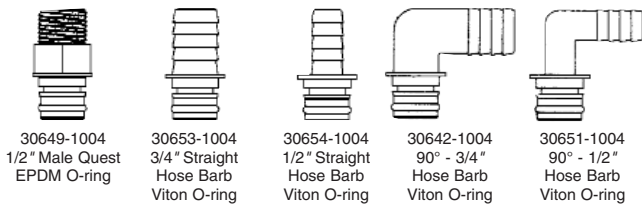

Port Kits contain two ports with O-rings

PERFORMANCE CURVES

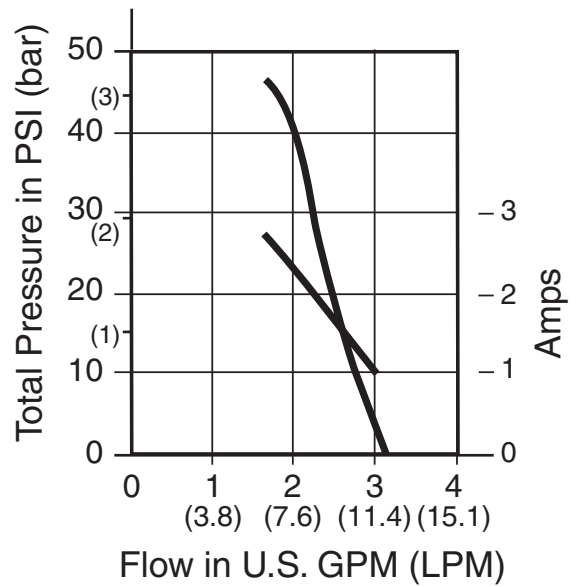

EXPLODED VIEW

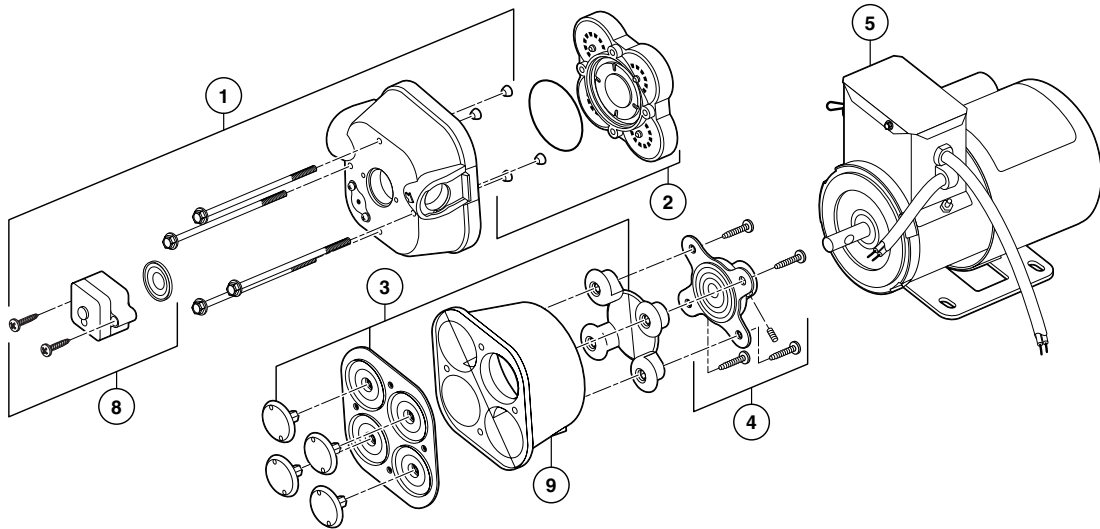

PARTS LIST

Model	① Upper Housing Kit	② Check Valve Kit	③ Diaphragm Kit	④ Cam/Bearing Kit	⑤ Motor Kit	⑧ Pressure Switch Kit
31801-0115	18910-4007	18911-7020	18912-3040	18913-0003	18919-2125	18916-0118
31801-1305	18910-4007	18911-7030	18912-3040	18913-0003	18919-2125	18916-0118

Bearing cover (9) not included in diaphragm Kit (3)

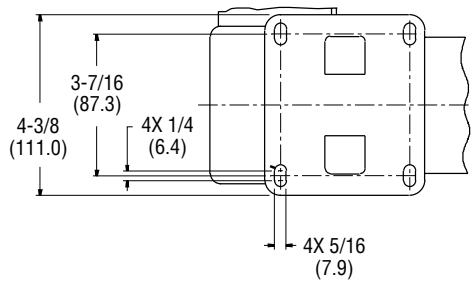
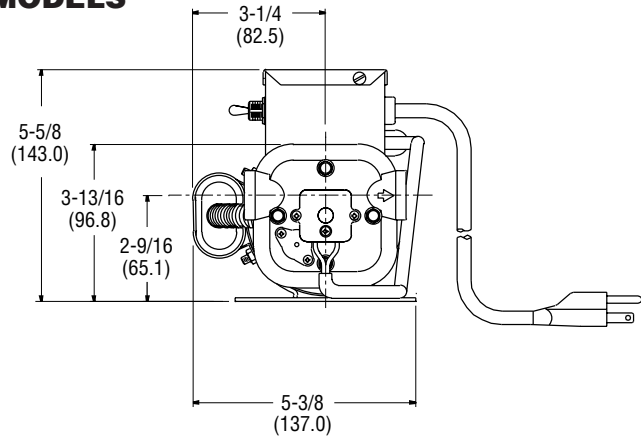
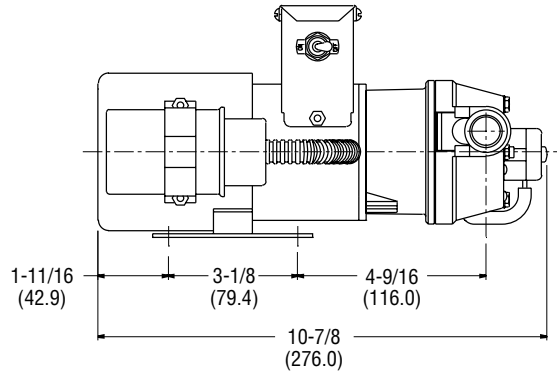
DIMENSIONS Inches (millimetres)**30801 MODELS****TROUBLESHOOTING****PULSATING FLOW**

Pump cycles on and off

- Restricted on outlet remove restriction or increase nozzle size

FAILURE TO PRIME

Motor operates, but no pump discharge

- Restricted intake or discharge line
- Air leak in intake line
- Punctured pump diaphragm
- Debris under check valves

MOTOR FAILS TO TURN ON

- Loose wiring connection
- Pump circuit has no power
- Blown fuse
- Thermal Protector Tripped
- Pressure switch failure
- Defective motor

PUMP FAILS TO TURN OFF

After discharge valve is closed

- Empty water tank
- Punctured pump diaphragm

- Discharge line leak
- Defective pressure switch
- Low voltage to pump
- Debris under check valves

LOW FLOW AND PRESSURE

- Air leak at pump intake
- Debris inside pump in check valves
- Worn bearing (excessive noise)
- Punctured pump diaphragm
- Defective motor

Jabsco



ITT Industries

Engineered for life

THE PRODUCTS DESCRIBED HEREIN ARE SUBJECT TO THE JABSCO ONE YEAR LIMITED WARRANTY, WHICH IS AVAILABLE FOR YOUR INSPECTION UPON REQUEST.

U.S.A.
Jabsco
20 Icon
Foothill Ranch, CA 92610-3000
Tel: 949.609.5106
Fax: 949.859.1254

UNITED KINGDOM
Jabsco
Bingley Road, Hoddesdon
Hertfordshire EN11 OBU
Tel: +44 (0) 1992 450145
Fax: +44 (0) 1992 467132

CANADA
Fluid Products Canada
55 Royal Road
Guelph, Ontario N1H 1T1
Tel: (519) 821.1900
Fax: (519) 821.2569

JAPAN
NHK Jabsco Company Ltd.
3-21-10, Shin-Yokohama
Kohoku-Ku, Yokohama, 222
Tel: 045.475.8906
Fax: 045.475.8908

GERMANY
Jabsco GmbH
Oststrasse 28
22840 Norderstedt
Tel: +49-40-53 53 73 -0
Fax: +49-40-53 53 73 -11