

# Model 30510-5XXX 30510-3XXX

## SELF-PRIMING PUMPS

### FEATURES

- Pump Type:** 30510-5XXX Close Coupled  
30510-3XXX Pump Head
- Body:** Epoxy Plastic
- Impeller:** Neoprene, Nitrile, Viton\* or EPDM
- Shaft Seal:** Mechanical, Carbon-on-Ceramic or Tungsten Carbide; Nitrile or Viton
- Ports:** 3/4" NPT External
- Shaft:** Epoxy Plastic Covered Stainless Steel
- Motor:** 115 Vac, Single Phase, 60 Hz, 3/4 HP, 1750 RPM, TEFC, 56C Frame, C-Face, Overload Protected, Capacitor Start.
- Weight:** 30510-5XXX 35.0 lb (15.9 kg) Approx.  
30510-3XXX 6.5 lb (3.0 kg) Approx.

**WARNING** Explosion hazard. Motor can spark. Explosion & death can occur. Do not use where flammable vapors are present.

### APPLICATIONS

**INDUSTRIAL:** Circulating and transferring corrosive liquids. Returning spilled liquids to process. Transferring foaming solutions with entrained air, such as soaps and detergents. Sampling and pilot plant installations. Handles pure solutions, acids, alkalies, photochemicals, dyes, detergents, waxes, gels, solutions with suspended solids and emulsions.

**METAL PLATING:** Filtration of plating solutions. Filling and emptying vats. Adding chemicals for pH balance.

**PHARMACEUTICAL:** Processing lab solutions, medicines, lotions and preparations. Filtering pharmaceutical solutions.

**AGRICULTURAL:** Transferring liquid fertilizers, herbicides and pesticides.

### OPERATING INSTRUCTIONS

1. **INSTALLATION** – Pump may be mounted in any position. The rotation of the pump shaft determines the location of the pump's intake and discharge ports. (Refer to dimensional drawing.) Pump is

**WARNING** Explosion hazard. Do not pump gasoline, solvents, thinners or other flammable liquids. To do so can cause an explosion resulting in injury or death.

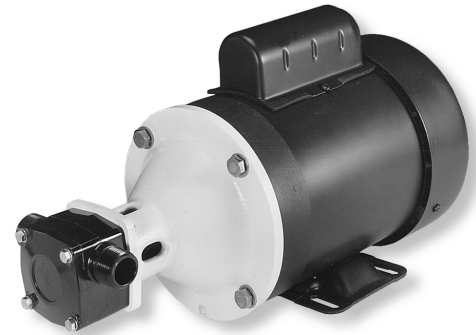

Model 30510-5XXX, 30510-3XXX

### VARIATIONS AVAILABLE

Model	Description
30510-5001 30510-3001	Standard Pressure, Neoprene Impeller, Carbon Seal
30510-5003 30510-3003	Standard Pressure, Nitrile Impeller, Carbon Seal
30510-5004 30510-3004	Standard Pressure, Viton Impeller, Carbon Seal
30510-5101 30510-3101	Standard Pressure, Neoprene Impeller, Tungsten Carbide Seal
30510-5103 30510-3103	Standard Pressure, Nitrile Impeller, Tungsten Carbide Seal
30510-5104 30510-3104	Standard Pressure, Viton Impeller, Tungsten Carbide Seal

normally assembled at factory for clockwise rotation (looking at end cover). If counter clockwise rotation is desired, follow steps 1 and 2 of disassembly and step 7 of assembly instructions to change direction of impeller blade deflection under cam.

2. **MOTOR SELECTION** – Pump head is designed to fit a 56C Frame NEMA C-face motor. Motor should be rated 3/4 horsepower at 1750 RPM with a service factor of one. Due to high bearing loads, motor should be ball bearing equipped with the front bearing locked against axial movement. Motor should be capacitor start and foot mounted.

\* Viton is a registered trademark of Du Pont Dow Elastomers L.L.C.

3. SELF-PRIMING – Primes at low or high speeds. For vertical dry suction lift of 10' (3m) (neoprene/nitrile/viton) – 6' (1.8m) (EPDM), a minimum of 860 RPM is required. Pump will produce suction lift up to 22' (6.7m) when wet.

BE SURE SUCTION LINES ARE AIRTIGHT OR PUMP WILL NOT SELF-PRIME.

4. DISCHARGE – When transferring liquids further than 25' (7.6m), use one size larger discharge line than discharge port size.
5. RUNNING DRY – Unit depends on liquid pumped for lubrication. DO NOT RUN DRY for more than 30 seconds. Lack of liquid will damage the impeller.
6. CHEMICAL COMPATIBILITY – Consult the Chemical Resistance Guide in the JABSCO Industrial Pump Catalog (available upon request from the factory) for proper body materials and impeller compounds. If corrosive fluids are handled, pump life will be prolonged if pump is flushed with a neutralizing solution after each use or after each work day. A Tungsten Carbide Seal variation is available for pumping liquids that contain abrasives or are highly corrosive.
7. PRESSURES – Consult Performance Curve for maximum recommended pressure for pumps in continuous operation. If pressures exceed those shown, consult the factory.
8. TEMPERATURES – The operating temperature limits of the pump depend on the impeller compound. The following ranges apply:  
 Neoprene - 45° to 180°F (7° to 82°C),  
 Nitrile - 50° to 180°F (10° to 82°C),  
 Viton - 60° to 180°F (15° to 82°C),  
 EPDM - 45° to 185°F (7° to 85°C).
9. IMPELLER TORQUE – The torque required to initiate rotation of a new impeller in a dry pump body is:  
 Standard Pressure Impeller (14281-Series):  
 Forward = 1.5 pounds force - feet  
 Reverse = 4.3 pounds force - feet  
 These values may vary slightly due to impeller compounding, blade set, and body material of construction. Consult factory for more information.
10. SPARE PARTS – To avoid costly shutdowns, keep a spare JABSCO impeller, seal and O-ring set on hand.

## SERVICE INSTRUCTIONS

### DISASSEMBLY

1. Remove the four end cover screws. Remove end cover and O-ring.
2. Remove the four screws, holding the body to the adapter flange. Slide body, complete with impeller and wearplate, from adapter and shaft.
3. Remove mechanical seal by inserting two screwdrivers behind seal collar, and gently lever collar and seal assembly forward on shaft. Use extreme care not to mar shaft surface. Remove seal seat and rubber cup from recess in wearplate.

4. Remove the four screws holding the adapter to the motor and remove the adapter.
5. Stub shaft is held in place with set screws and Loctite\* RC/680 retaining compound. Extreme care must be taken not to damage the motor shaft and bearings when removing the stub shaft. Heat shaft joint area to facilitate disassembly of set screws and stub shaft from motor shaft. DO NOT EXCEED 300°F when heating joint area. Once joint area has been heated, remove set screws and slide stub shaft from motor shaft.

### ASSEMBLY

1. Liberally apply Loctite RC/680 retaining compound to the motor shaft and slide the stub shaft on, positioning the base of the stub shaft 0.37" from the bolt mounting surface of motor and two of the four set screw holes over the keyway in the motor shaft. For clarification refer to figure 1 below. Loctite aids in preventing fretting and subsequent shaft failure. Wipe off excess Loctite. Apply Loctite to the two dog point (flat point) set screws, position in the set screw holes aligned with the keyway of the motor shaft and torque to 55-60 in.-lbs. Apply Loctite to the two cap point screws and torque to 85 - 90 in.-lbs.
2. Replace the adapter on the motor and tighten the four mounting screws to 20 ft.-lbs.
3. Replace mechanical seal by sliding spacer onto shaft up to locating shoulder, then smear shaft with light lubricating oil. Push on seal gently until it engages with spacer. Fit rubber cup and seal seat into wearplate.
4. Insert impeller in pump body, fit O-ring in each end of the pump body.
5. Slide body assembly over shaft. Fit body to adapter screws. Torque screws to 10 in.-lbs.  
 NOTE: Cracking of body may occur. DO NOT overtighten screws.
6. Fit end cover and end cover screws. Torque screws to 10 in.-lbs.
7. Changing Pump Rotation (looking at end cover):
  - a. Clockwise Rotation: Insert impeller into pump body with blades bending counterclockwise
  - b. Counterclockwise Rotation: Insert impeller into pump body with blades bending clockwise.

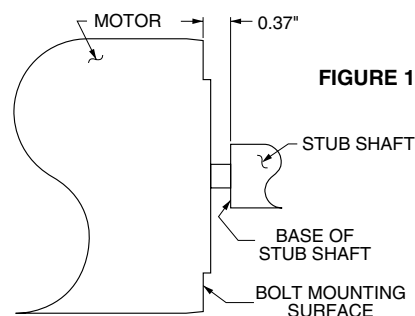
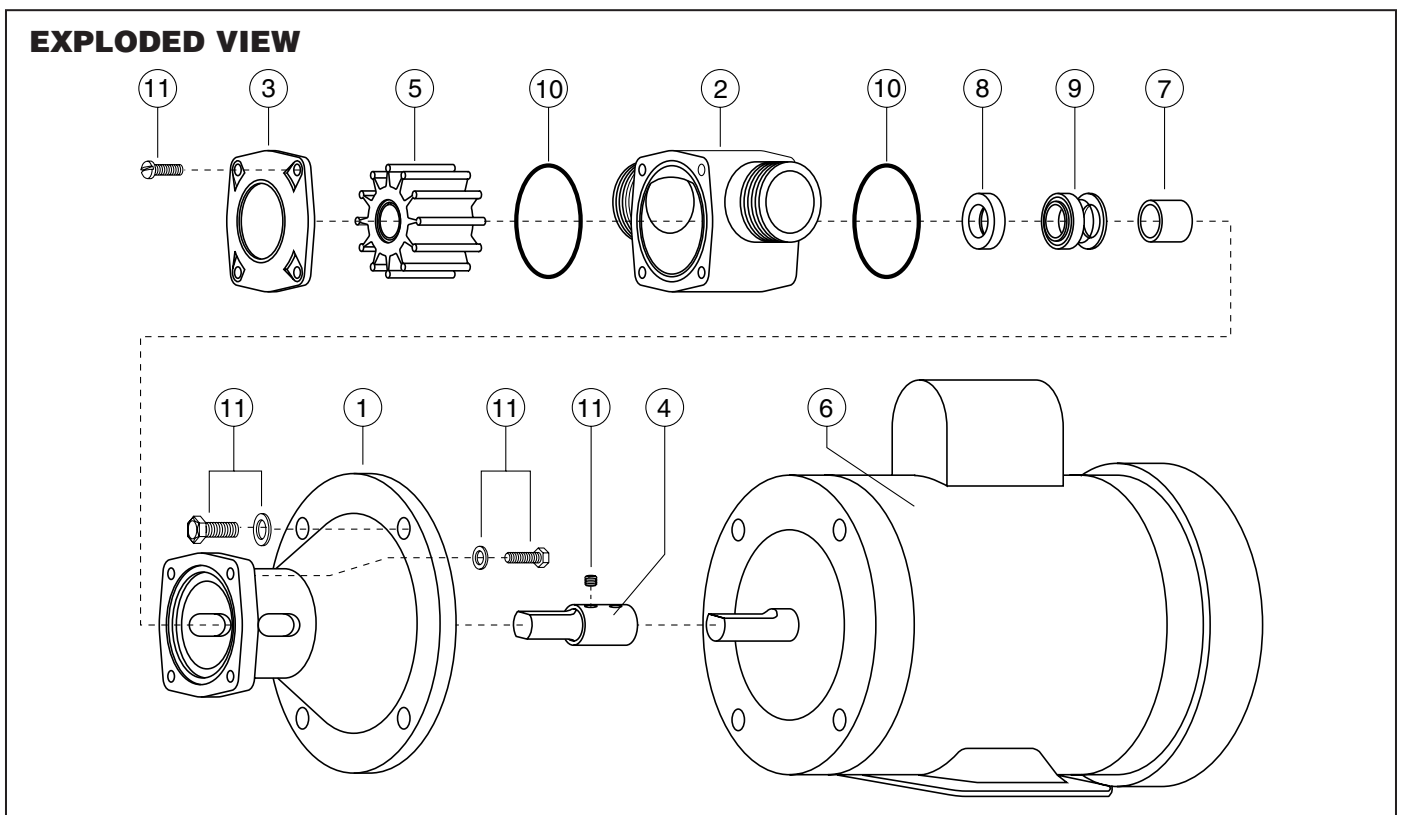

FIGURE 1

\* Loctite is a trademark of Loctite Corporation.

## PARTS LIST

Key	Description	Qty. Req.	Model 30510-5XXX Part Number	Qty. Req.	Model 30510-3XXX Part Number
1	Adapter	1	18753-0215	1	18753-0215
2	Body	1	18753-0188	1	18753-0188
3	End Cover	1	18753-0194	1	18753-0194
4	Shaft	1	18753-0210	1	18753-0210
5	Impeller:	1		1	
	Standard Pressure - Neoprene		14281-0001		14281-0001
	Standard Pressure - Nitrile		14281-0003		14281-0003
	Standard Pressure - Viton		14281-0004		14281-0004
	Standard Pressure - EPDM				7614-0002
6	Motor, 3/4 HP, 115Vac, 1Ph, 60Hz, TEFC, C-Face, 56C Frame	1	18753-0219	-	-
7	Seal Spacer	1	18753-0223	1	18753-0223
8	Seal Seat: Nitrile	1	18753-0233	1	18753-0233
	Ceramic: Viton		18753-0234		18753-0234
9	Seal Mech.: Carbon - Nitrile	1	18753-0241	1	18753-0241
	Carbon - Viton		18753-0242		
	Tungsten Carbide - Viton		18753-0244		18753-0244
10	O-Ring: Nitrile	2	18753-0261	2	18753-0261
	Viton		18753-0262		18753-0262
11	Screw Kit:	1	18753-0280	1	18753-0280
	consists of:				
	Screws, Hex Hd. 3/8-16 x 1"	(4)			
	Screws, Hex Hd. M5 x 16mm	(4)			
	Screws, Pan Hd. M5 x 8mm	(4)			
	Set Screw, Cup Pt. 1/4-20 x 1/4	(2)			
	Set Screw, Dog Point 1/4-20x1/2	(2)			
	Washers, Flat 3/8	(4)			
	Washers, Flat M5	(4)			



## DIMENSIONAL DRAWINGS

Inches (Millimeters)

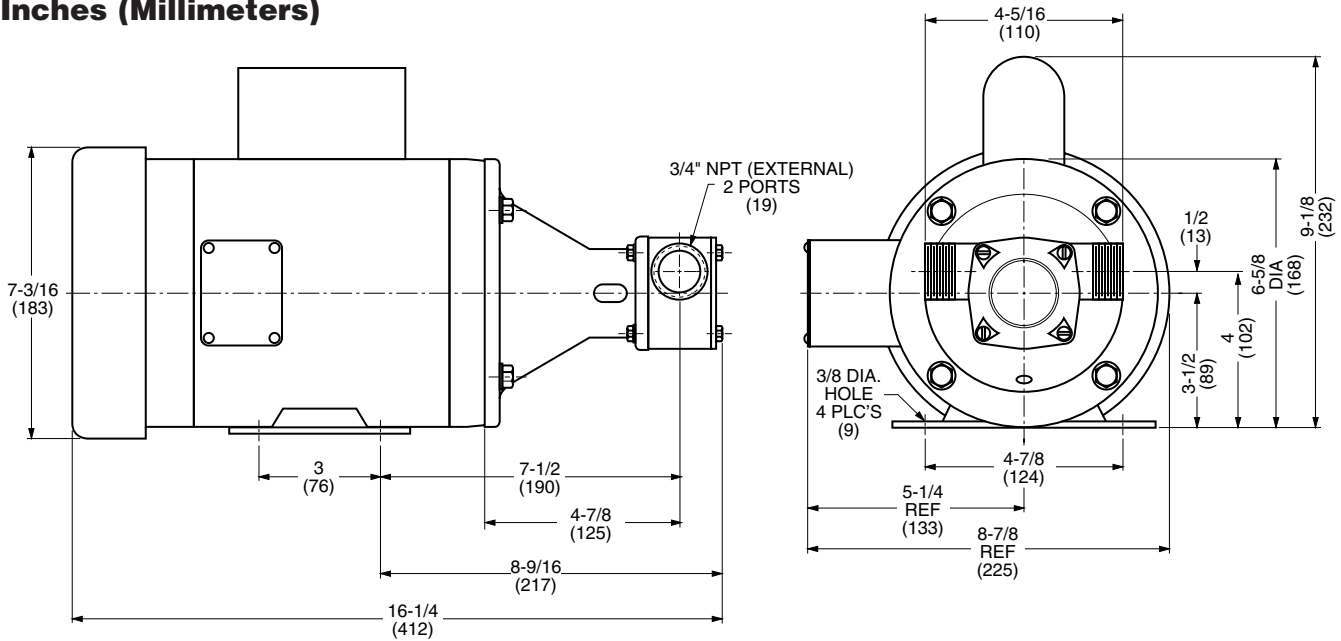

## PERFORMANCE CURVES

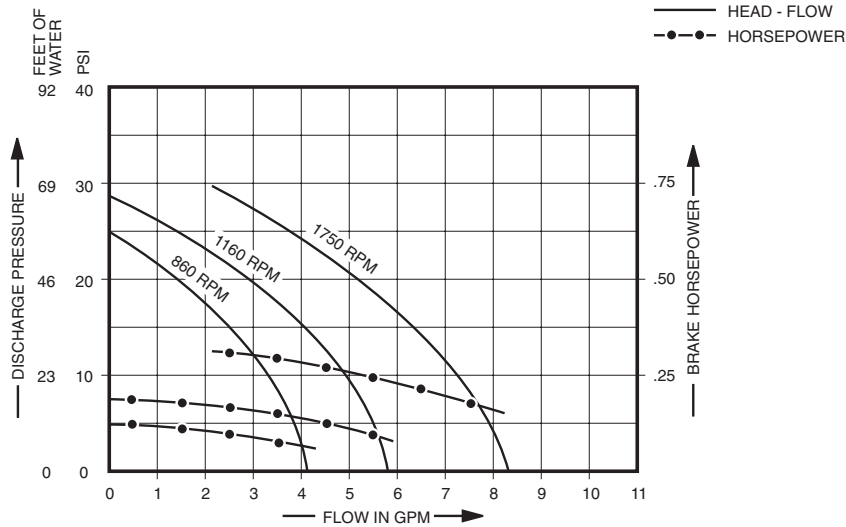

NOTE: Curve shows approximate head-flow for new pumps with neoprene impeller pumping water.  
Capacities should be reduced approximately 10% with nitrile impeller.

Consult factory for specific performance information.

# Jabsco



**ITT Industries**  
*Engineered for life*

THE PRODUCTS DESCRIBED HEREIN ARE SUBJECT TO THE JABSCO ONE YEAR LIMITED WARRANTY, WHICH IS AVAILABLE FOR YOUR INSPECTION UPON REQUEST.

U.S.A.  
Jabsco  
20 Icon  
Foothill Ranch, CA 92610-3000  
Tel: (949) 609.5106  
Fax: (949) 859.1254

UNITED KINGDOM  
Jabsco  
Bingley Road, Hoddesdon  
Hertfordshire EN11 0BU  
Tel: +44 (0) 1992 450145  
Fax: +44 (0) 1992 467132

CANADA  
Fluid Products Canada  
55 Royal Road  
Guelph, Ontario N1H 1T1  
Tel: (519) 821.1900  
Fax: (519) 821.2569

JAPAN  
NHK Jabsco Company Ltd.  
3-21-10, Shin-Yokohama  
Kohoku-Ku, Yokohama, 222  
Tel: 045.475.8906  
Fax: 045.475.8908

GERMANY  
Jabsco GmbH  
Oststrasse 28  
22840 Norderstedt  
Tel: +49-40-53 43 73 -0  
Fax: +49-40-53 53 73 -11