

“CENTRI PUPPY”

Bronze Centrifugal DC Motor/Pump Unit

FEATURES

Body & Impeller:	Bronze
Seal:	Mechanical Face Seal
Port Size:	3/4" NPT Internal
Motor:	Permanent Magnet, Fully Enclosed, Ignition Protected
Shaft:	Stainless Steel
Weight:	5 lb (2,3 kg) approx.

Motor meets USCG Electrical Standards (Title 33, Chapter I, Part 183; Subpart I) for IGNITION PROTECTION on gasoline powered vessels.



Model: 18510-Series

⚠ WARNING	Explosion hazard. Do not pump gasoline, solvents, thinners or other flammable liquids. To do so can cause an explosion resulting in injury or death.
------------------	---

⚠ WARNING	Explosion hazard. Do not operate with rivets removed from motor case. Explosion resulting in personal injury, death or property damage can occur. Case openings must be sealed to avoid explosion and maintain ignition protected rating.
------------------	--

VARIATIONS AVAILABLE

MODEL	DESCRIPTION
18510-0020	12 Vdc
18510-0021	24 Vdc

PERFORMANCE (Nominal 12 Vdc System)

AMPS	FT. OF WATER	GPM
8	2	15
7	6	11
6.3	10	5.5
5.3	13	Shutoff

APPLICATION

Suited for many general pumping applications where a flooded intake condition exists. This pump is NOT SELF-PRIMING. Typical uses include livewell filling and circulation, diesel fuel transfer (NOT GASOLINE), and other applications not requiring a self-priming pump.

INSTALLATION

The pump must be mounted in a dry location – the motor is not waterproof and must not be submerged. The unit can be mounted in any desired position. It is best to mount so that water dripping from loose port connection will not wet the motor. The pump head may be mounted at 180° on the motor to accommodate plumbing as needed. The pump may be mounted vertically on a thru-hull and seacock for applications requiring overboard water to be pumped aboard. A seacock must be used between the hull inlet fitting and pump on below-waterline installations.

ELECTRICAL CONNECTIONS

⚠ WARNING



Explosion hazard. If pump is operated in an area containing flammable vapors, wire leads must be joined by insulated mechanical locking connectors. Loose or inadequate wire connections can spark resulting in an explosion. Property damage, injury or death can occur.

Connect black wire to negative (-) terminal of battery. The orange wire should run to a properly sized (see electrical specification) overload protected switch or circuit breaker, with a wire from switch or breaker to positive (+) terminal of battery. Electrical circuit must be independent of all other accessories. Use proper wire size as determined by wire table elsewhere on this sheet.

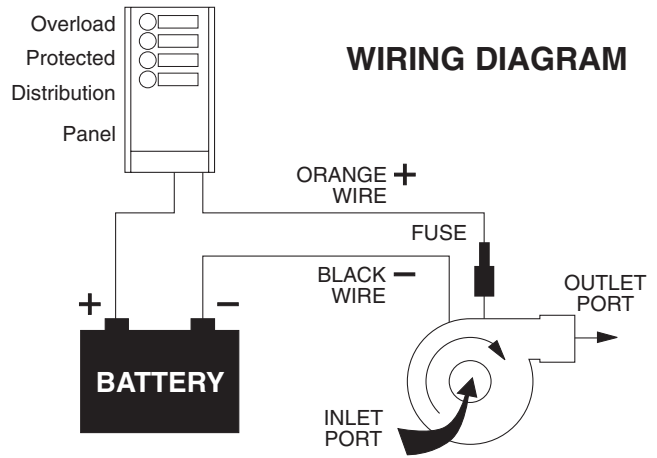

MINIMUM WIRE SIZES

CONNECTION LENGTH BETWEEN BATTERY AND MOTOR	12V	24V
1-10 ft. (3m)	#12	#16
11-20 ft. (6m)	#10	#16
21-30 ft. (9m)	# 8	#12

ELECTRICAL SPECIFICATIONS

	12V	24V
Amp. Draw (Approx.)	8	4
Fuse Size	10	5

PLUMBING CONNECTIONS

The intake and outlet ports have internal 3/4" pipe threads. Brass or plastic pipe fittings may be used to suit the installation. Plastic fittings that may be subject to cracking due to vibration should not be used below the waterline. TFE pipe joint tape or compound should be used if brass fittings are installed in pump. Hose may be used with common pipe adaptors installed in the pump ports.

OPERATION

The pump may be run dry for short periods of time. However, running without liquid allows heat to build up between seal faces, thus shortening seal life. The pump can run against a closed outlet such as encountered when using a garden hose type shut-off nozzle. Small particles of trash and debris will pass through the pump, though an intake strainer should be fitted if excessive problems are encountered with pump clogging.

⚠ CAUTION



Motor runs hot; about 180°F is a normal temperature. Prolonged contact during operation may cause a burn.

MAINTENANCE

Check all electrical connections periodically, particularly in salt water areas. Corrosion can cause loss of performance or non-operation in extreme cases. The motor should be protected with a corrosion inhibiting spray and any rust should be removed and the motor repainted.

EXPLODED VIEW

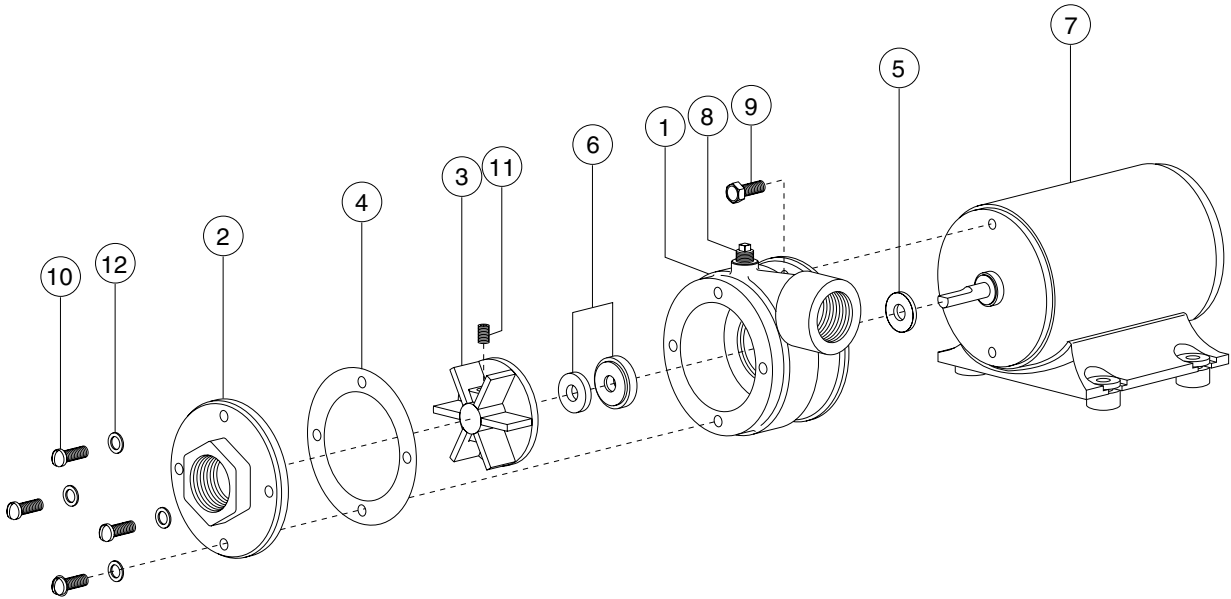

PARTS LIST

KEY	DESCRIPTION	PART NUMBER	QTY. REQ'D
1	Pump Body	18527-0000	1
2	End Cover	18514-0000	1
3	Impeller	18526-0000	1
4	Gasket	18516-0000	1
5	Slinger	6342-0000	1
6	Seal, Mechanical	96080-0552	1
7*	Motor 12 Vdc	18517-0000	1
	Motor 24 Vdc	18517-0001	1
8	Plug	92650-0040	1
9	Body Mounting Screw	98019-0020	2
10	End Cover Screw	91027-0013	4
11	Impeller Set Screw	18753-0492	1
12	Lock Washer #10 S.S.	91602-0020	4

* Includes motor base

SERVICE INSTRUCTIONS

NOTE: The seal consists of two parts. The half with the metal case and carbon face go into the pump body. The other half of the seal is a ceramic disc with a rubber boot and is installed into the back face of the impeller.

Disassembly

1. Remove end cover screws, end cover and gasket.
2. Remove pipe plug in top of body and rotate impeller so the set screw aligns with the plug hole. Insert a 1/8" allen wrench through the plug hole and remove the impeller set screw. Remove the impeller. Clean the threads of the set screw and the impeller.
3. Remove screws securing the body to the motor and remove the body.

4. Remove the old ceramic half of the seal from the pump impeller with a screwdriver or hooked wire.
5. From the motor side of the body press the metal case seal half out of the body into the impeller bore. Clean the seal bore areas in both the body and the impeller.

Assembly

1. **Apply a thin coat of sealant, such as Loctite* 272, to the outside diameter of the seal before installation.** Install the new seal from inside the body using a hollow tube 1 1/4" OD by 1 1/8" ID. With the tube against the flange of the seal press or tap gently on the tube until the flange of the seal is seated all the way around on the ledge in the body. Lubricate the rubber boot with a small amount of soapy water. To protect the seal surface put a clean piece of paper on the ceramic face and push the seal by hand into the impeller bore until it is completely seated. Be sure that both the carbon and the ceramic faces are clean of grease and fingerprints.
2. Install the body to the motor. Position the motor with the pump body up and the back of the motor down to correctly position the shaft end play.
3. **Apply one drop of sealant (such as Loctite 242 or equivalent) to the threads of the impeller set screw** and screw it part way into the impeller. Rotate the motor shaft so the flat of the shaft faces the pipe plug hole in the body. Slide the impeller on the shaft with the set screw facing the plug hole in the body. Press the impeller down compressing a spring in the seal until the impeller bottoms out against the body. Tighten the set screw in the impeller before releasing pressure against the impeller. This sets the proper seal face clearance.
4. Install the pipe plug into the body.
5. Apply a thin coat of sealant to the threads of the pipe plug and ensure the body and end cover surfaces are clean where they contact the gasket. Align the end cover and new gasket with the body and secure it with the end cover screws.

*Loctite is a trademark of Loctite Corporation.

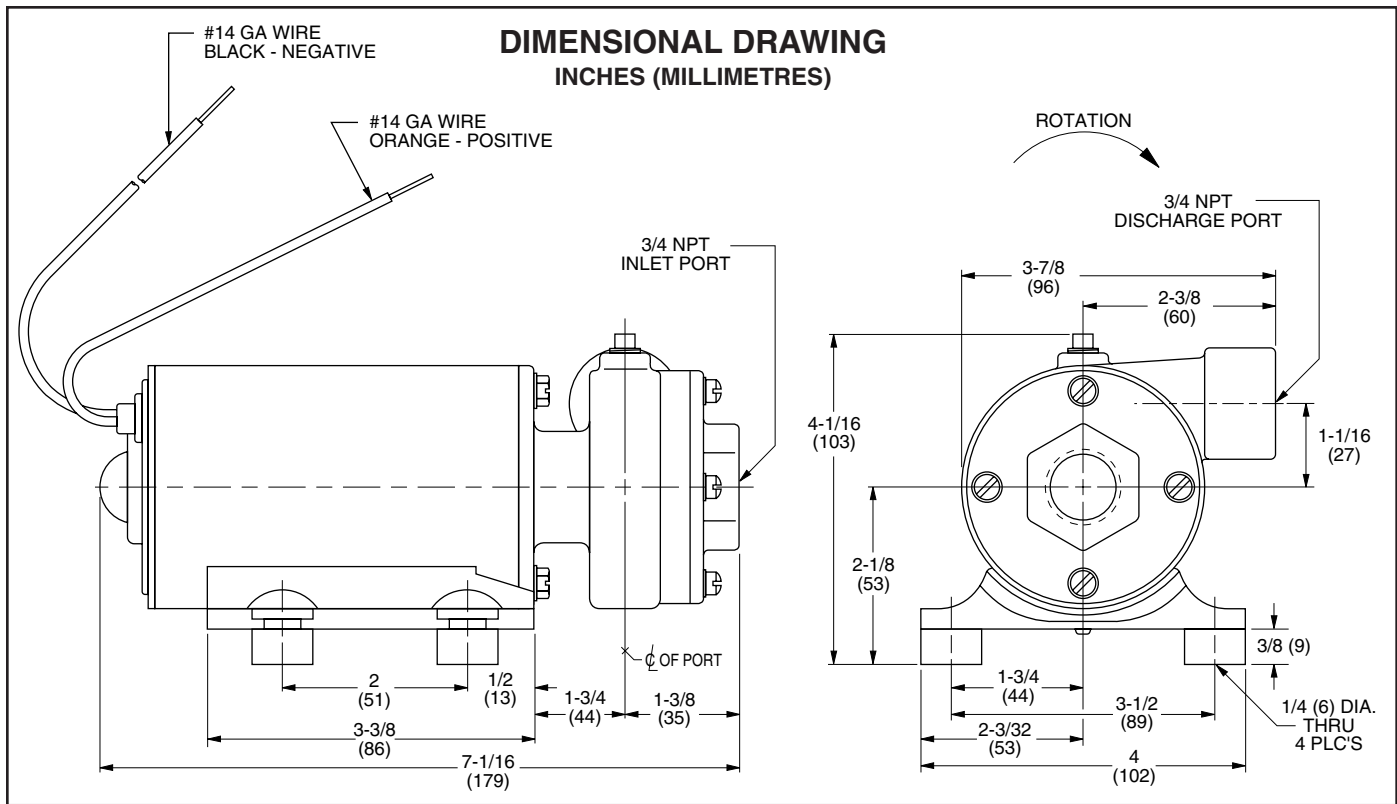

Jabsco



THE PRODUCTS DESCRIBED HEREIN ARE SUBJECT TO THE JABSCO ONE YEAR LIMITED WARRANTY, WHICH IS AVAILABLE FOR YOUR INSPECTION UPON REQUEST.

U.S.A.
Jabsco
20 Icon
Foothill Ranch, CA 92610-3000
Tel: 949.609.5106
Fax: 949.859.1254

UNITED KINGDOM
Jabsco
Bingley Road, Hoddesdon
Hertfordshire EN11 OBU
Tel: +44 (0) 1992 450145
Fax: +44 (0) 1992 467132

CANADA
Fluid Products Canada
55 Royal Road
Guelph, Ontario N1H 1T1
Tel: (519) 821.1900
Fax: (519) 821.2569

JAPAN
NHK Jabsco Company Ltd.
3-21-10, Shin-Yokohama
Kohoku-Ku, Yokohama, 222
Tel: 045.475.8906
Fax: 045.475.8908

GERMANY
Jabsco GmbH
Oststrasse 28
22840 Norderstedt
Tel: +49-40-53 53 73 -0
Fax: +49-40-53 53 73 -11