



a xylem brand

SELF-PRIMING PUMPS

FEATURES

- Body:** Plastic
- Impeller:** Jabsco Neoprene compound
- Seal:** Lip Type
- Ports:** Slip-on Barbs for 5/8" ID hose
- Motor:** Permanent Magnet Type, Fully Enclosed, with Stainless Steel Shaft
Complies with USCG Electrical Standards (Title 33, Chapter I, Part 183; Subpart 1) for IGNITION PROTECTION on gasoline powered vessels.

Dimensions: 3-1/4" (83mm) high,
6-1/2" (165mm) long,

VARIATIONS AVAILABLE

Model	Voltage DC	AMP Draw	Fuse Size
12560	12	7	10

⚠ WARNING Explosion hazard. Do not pump gasoline, solvents, thinners or other flammable liquids. To do so can cause an explosion resulting in injury or death.

⚠ WARNING Explosion hazard. Do not operate with rivets removed from motor case. Explosion resulting in personal injury, death or property damage can occur. Case openings must be sealed to avoid explosion and maintain ignition protection rating.

5" (127mm) wide

Weight: 4-1/2 lbs. (2 kg) Approx.

APPLICATION

Use for bilge pumping, live well circulation, washdown and general pumping requirements. If bilge water contains significant amounts of oil, the standard impeller must be replaced with a nitrile impeller #6303-0003 to avoid impeller swell. With a wet impeller, pump will produce a suction lift of about 4 feet (1.2m) and lift of 20 feet (6m) when primed. If the pump is dry, it will prime about 1.5 feet (0.47m). BE SURE SUCTION LINES ARE AIRTIGHT.

INSTALLATION

The pump must be mounted in a dry location. The motor is not waterproof and must not be submerged.



Model 12560-0001

SELECTION OF A COOL, VENTILATED location will generally extend pump motor life. The unit can be mounted in any desired position. It is best to mount so that water dripping from loose port connection will not wet the motor. The pump head may be mounted at 180° increments on the motor to allow change in flow direction.

OPERATING INSTRUCTIONS

Flexible impeller pumps must not be run dry, as the pumped liquid is the lubricant for the impeller. Observe the outlet and shut off pump as soon as liquid stops flowing. An automatic level switch is convenient to control the pump.

Notice: If pump is idle for extended periods, the impeller may stick to the pump body, preventing motor rotation and causing blown fuses. To correct, remove end cover and impeller. Clean body and impeller, then lubricate with water or small amounts of grease before assembly.

Temperature of pumped liquid may be in the range of 45° - 1600°F (10°-70°C) or 8.7 psi.

Pressure for normal operation should not exceed 20 feet of head (6.1m).

CAUTION: Motor runs hot. Nominal motor temperature is 180°F (82°C). Prolonged contact during operation may cause a burn.

HEAD CAPACITY TABLE

P.S.I.	Total Head		Capacity	
	Feet	Meters	GPM	L/Min.
—	Open flow	—	5.0	18.9
2.1	5	1.5	4.6	17.4
4.3	10	3.0	3.7	14.0
8.7	20	6.1	1.7	6.4

PLUMBING CONNECTIONS

Pumps have slip-on fittings for 5/8" ID hose. Use hose that does not kink when bent and with sufficient wall thickness to prevent collapse when used on suction side of pump. Hoses should be routed so that some water will be retained to pump body to wet the impeller. Wetting the impeller aids in priming and extends impeller life. Use a strainer on the intake hose to stop trash and solids from going through the pump. All hoses must have airtight connections to enable faster priming.

When units have been idle or stored for long periods of time, the impeller may stick to the pump body causing fuse to blow. Remove end cover and manually free

 WARNING	Explosion hazard. If pump is operated in an area containing flammable vapors, motor wire leads must be joined by insulated mechanical locking connectors. Loose or inadequate wire connections can spark resulting in an explosion. Property damage, injury or death can occur.
---	--

impeller. Replace end cover and fuse.

ELECTRICAL CONNECTIONS

Connect black wire to negative (-) terminal of battery. The orange wire should run to a fused overload protected switch or circuit breaker with a 10 amp rating, with a wire from switch or breaker to positive (+) terminal of battery. Electrical circuit must be independent of all other accessories. Failure to connect black wire to negative and orange wire to positive will result in backwards motor rotation and possible motor and pump damage. Correct motor rotation is clockwise looking at shaft end

MINIMUM WIRE SIZES

Wire Length Between Battery and Motor	12V DC
1-10 ft (3m)	#12
11-20 ft (6m)	#10
21-30 ft (9m)	#8

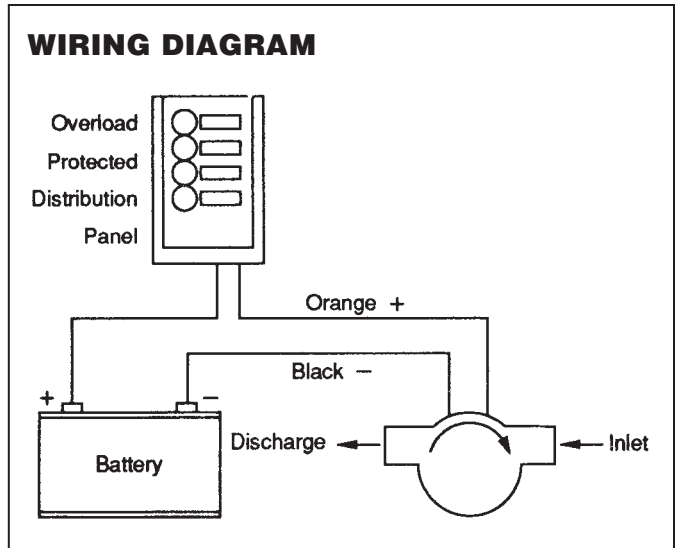

EXPLODED VIEW

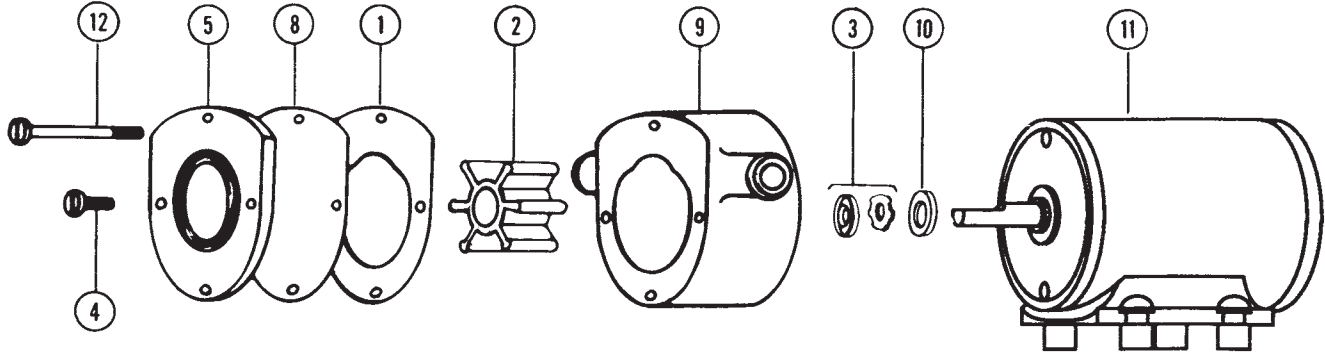

PARTS LIST

Key	Description	Qty.	Part Number
*1	Gasket	1	12558-0000
†*2	Impellers	1	6303-0001
*3	Seal	1	1040-0000
4	Screw (End Cover)	2	91014-0020
5	End Cover	1	12555-0000
8	Wearplate	1	12557-0000
9	Body	1	12554-0000
10	Slinger	1	6342-000
11	Motor 12V DC	1	98012-0020
12	Screw (Motor to Body)	2	91014-0010
	Replacement Pump (head only)		12590-0001
	Service Kit		90126-0001

* Parts contained in Service Kit.

† 6303-0003 Oil Resistant "Nitrile" Impeller available separately.

INSTALLATION

DISASSEMBLY

1. Remove top and bottom end cover screws and remove pump head from motor.
2. Remove remaining end cover screws.
3. Remove end cover, wearplate, and gasket
4. Withdraw impeller.
5. Pry seal retainer from seal cavity and press seal out of cavity from impeller bore side.
6. **NOTE:** Do not tamper with or disassemble motor.

ASSEMBLY

1. Lubricate seal and press into seal cavity, with open side of seal facing impeller. Center seal retainer (concave side up) in seal cavity and press firmly against seal using 11/16" diameter dowel.
2. Install slinger on shaft 1/16" from motor hub. Lubricate motor shaft.

3. Locate body on motor.
4. Align flat in impeller with motor shaft flat and install impeller into impeller bore.
5. Replace gasket, wearplate, end cover, and end cover screws.
6. Secure pump head to motor with long machine screws.

MAINTENANCE

Check wires and connections to be sure corrosion is not adding additional resistance to the motor circuit and causing a low voltage condition at the motor. Low voltage can inhibit motor from starting and can cause fuse to blow. Full voltage should be available to prevent motor damage.

If pump is to be in freezing temperatures, drain by loosening end cover.

Service kits, or at least spare impellers, should be

DIMENSIONAL DRAWING

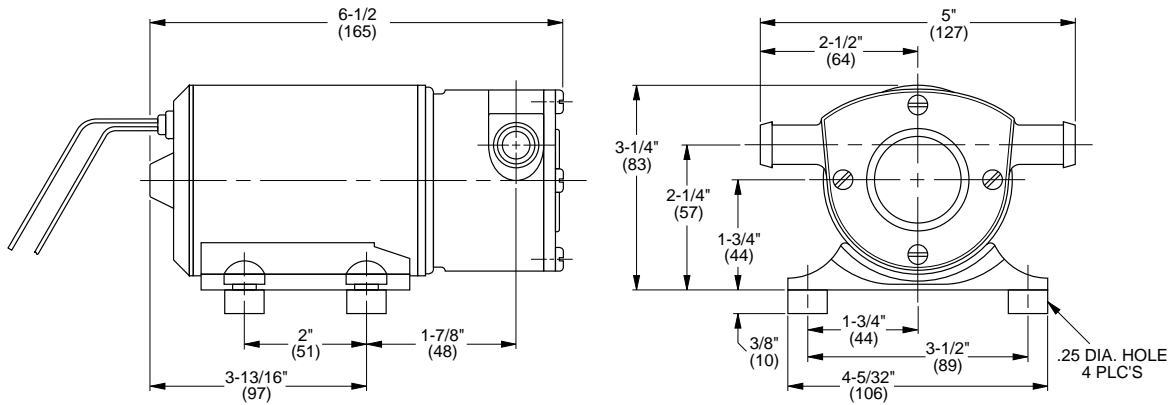

A. LIMITED WARRANTY:

Jabsco warrants that at the time of shipment, the products manufactured by Jabsco and sold hereunder shall be in conformity with applicable written specifications and descriptions referred to or set forth herein, free from defects in material and workmanship, merchantable, and suitable for a particular purpose, provided such is implied by State law under the circumstances of this sale.

B. WARRANTY ADJUSTMENT:

1. Jabsco agrees to repair or furnish a replacement for, but not to remove or install, any product or component thereof which, within one (1) year from date of purchase, shall upon test and examination by Jabsco prove defective within the above warranty. Receipt verifying purchase date is required to obtain adjustment.
2. Buyer shall notify Jabsco of any defect within this warranty no later than ninety (90) days after the defect is discovered.

C. EXCLUSIONS FROM WARRANTY AND LIMITATION OF LIABILITY:

1. The foregoing warranty is limited solely as set forth herein and applies only for the period designated above.
2. ITT SHALL NOT BE LIABLE FOR ANY LOSS, DAMAGE, SPECIAL OR CONSEQUENTIAL DAMAGE OF ANY KIND, WHETHER BASED UPON WARRANTY, CONTRACT, NEGLIGENCE, OR STRICT LIABILITY ARISING IN CONNECTION WITH THE SALE, USE, OR REPAIR OF THE PRODUCT.
3. THE MAXIMUM LIABILITY OF ITT IN CONNECTION WITH THIS WARRANTY SHALL NOT IN ANY CASE EXCEED THE CONTRACT PRICE FOR THE PRODUCT CLAIMED TO BE DEFECTIVE OR UNSUITABLE.
4. This warranty does not extend to any product manufactured by

Jabsco which has been subjected to misuse, neglect, accident, improper installation, or use in violation of instructions furnished by Jabsco.

5. This warranty does not extend to or apply to any unit which has been repaired or altered at any place other than Jabsco's factory, or by persons not expressly approved by Jabsco, nor to any unit the serial number, model number, or identification of which has been removed, defaced or changed.
6. Components manufactured by any supplier other than Jabsco shall bear only that warranty made by the manufacturer of that product.
7. This warranty applies to products defined as "consumer products" by the Consumer Product Warranties Act as from time to time amended.

D. CONSUMER RIGHTS:

This warranty gives you specific legal rights, and you may have other rights which vary from state to state. Some states do not allow exclusion or limitation of damages.

STANDARD WARRANTY: If the products manufactured and sold hereunder are not Consumer Products, the warranty extended to Buyer shall be as set forth in subparagraphs (A), (B), and (C), **EXCEPT THAT ALL EXPRESS OR IMPLIED WARRANTIES OR MERCHANTABILITY OR SUITABILITY FOR ANY PARTICULAR PURPOSE ARE EXCLUDED.**

www.xylemflowcontrol.com

Jabsco, 100 Cummings Center, Ste. 535-N, Beverly, MA 01915
Tel: +1 978 281 0440 Fax: +1 978 283 2619

Jabsco, Bingley Road, Hoddesdon, Hertfordshire, EN11 0BU
Tel: +44 (0) 1992 450 145 Fax: +44 (0) 1992 467 132

NHK Jabsco Co Ltd, 3-21-10, Shin - Yokohama Kohoku-ku, Yokohama 222
Tel: +81 (0) 45 475 8906 Fax: +81 (0) 45 475 8908

Jabsco GmbH, Oststraße 28, 22844 Norderstedt
Tel: +49 (0) 40 53 53 73 0 Fax: +49 (0) 49 53 53 73 11

Jabsco Italia, s.r.l., Via Tommaseo, 6, 20059 Vimercate, Milano
Tel: +39 039 685 2323 Fax: +39 039 666 307

USA

UK

JAPAN

GERMANY

ITALY



a xylem brand