

*Installation, Operating, Maintenance and  
Spares Manual*

Hy~Line  
Rotary Lobe Pump

&

Ultima  
Rotary Lobe Pump

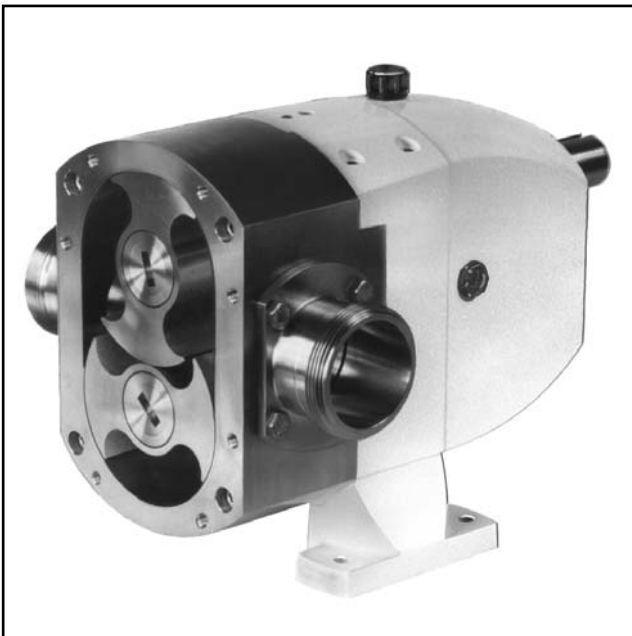

Jabsco



ITT Industries

## Contents

- 1. INTRODUCTION**
    - 1.01 Safety
    - 1.02 Principle of operation
    - 1.03 Operating conditions
    - 1.04 Model numbering system
    - 1.05 Inspection upon receipt
  - 2. INSTALLATION**
    - 2.01 Operating limitations
    - 2.02 Location & Positioning
    - 2.03 Drives
    - 2.04 Baseplate
    - 2.05 Guards and safety
    - 2.06 Electrical
    - 2.07 Pipework
    - 2.08 Enlarged rectangular inlet
    - 2.09 Temperature control jackets
    - 2.10 Seals and flushing
    - 2.11 Seal materials
    - 2.12 End Cover relief valve
    - 2.13 End cover barrier
    - 2.14 Overload protection
  - 3. LUBRICATION**
  - 4. START UP & ROUTINE CHECKS**
    - 4.01 Start up
    - 4.02 Daily Checks
    - 4.03 Weekly Checks
    - 4.04 Monthly Checks
    - 4.05 Six Monthly Checks
    - 4.06 Annual Checks
  - 5. CLEANING AND STERILIZING**
    - 5.01 Cleaning in place (CIP) & Manual cleaning
    - 5.02 Sterilizing in place (SIP)
  - 6. INSPECTION AND REPAIR**
    - 6.01 End cover
    - 6.02 Rotors
    - 6.03 Mechanical shaft seals - single primary
    - 6.04 Mechanical shaft seals - single flushed
    - 6.05 Mechanical shaft seals - double
    - 6.06 Seal housings
    - 6.07 Single o-ring seal
    - 6.08 Double o-ring seal
    - 6.09 Multi-Lip seal
    - 6.10 Rotor case
    - 6.11 Rotor clearance - checking & adjustment
    - 6.12 End cover relief valve
    - 6.13 Thermal jacket –end cover
    - 6.14 Thermal jacket –pump head
    - 6.15 Thermal jacket –rotor case
    - 6.16 Bearing housing - inspection & repair
    - 6.17 Gearbox shafts and gears
    - 6.18 Bearing set-up and pre-load
  - 7. MODEL NUMBER BUILD CODE**
  - 8. PARTS LIST AND EXPLODED DIAGRAMS**
    - 8.01 Parts List
    - 8.02 Hy~Line Exploded Diagram
    - 8.03 Ultima Exploded Diagram
    - 8.04 Hy~Line 3 Size Sectional View
    - 8.05 Options & Extras - Sectional Views
- DECLARATION OF INCORPORATION**

## Jabsco Hy~Line and Ultima Rotary Lobe Pumps Installation Operating and Maintenance Manual

### 1. INTRODUCTION

Hy~Line and Ultima are positive displacement rotary lobe pumps designed to pump delicate, viscous and particle-laden fluids as well as thin liquids which require an all stainless steel pump. They share many common features but the construction of Ultima differs to provide an exceptionally high standard of hygiene and cleanability. This entire manual applies to both pump ranges, except:

It is essential that anyone who will install, operate, or be involved with this equipment shall read the whole of this manual **before installing the pump**, as it contains important safety information. **Failure to follow these instructions could result in damage to the pump or injury to yourself or other people.**

Adherence to the procedures and specifications outlined in the following chapters will assist in providing economical and reliable operation throughout the life of the pump.

If service or repair other than that described in this manual should become necessary, contact your supplier for assistance.

Any pump returned to the supplier for any reason must be fully cleaned and decontaminated and accompanied by details of what fluids have been pumped, including full Health and Safety information (MSDS sheets) if any of those fluids are hazardous.

All figures in brackets ( ) throughout this manual refer to the component key numbers used on the cross-sectional drawings and the spare parts lists.

#### 1.01 SAFETY

Throughout this manual your attention is drawn to certain procedures which must be followed to ensure safe operation and servicing of this product.



**DO NOT** ignore safety instructions.



**DO NOT** remove, by-pass or tamper with safety devices.



**DO NOT** use this equipment if the end cover (122) is removed, guards are missing or inlet & outlet pipework is not connected.



**DO NOT** forget the hazards of moving parts, high fluid pressure, extremes of temperature, hazardous liquids, electricity. Always isolate and lock-out pump drive motor before inspecting or servicing pump.

**1.02 PRINCIPLE OF OPERATION**

Hy~Line and Ultima pumps have 2 rotors which turn in opposite directions. Fluid enters the pump from the inlet port and fills the space between the rotors. This fluid is carried around the outside of the rotors and is forced out of the discharge port as the rotor lobes mesh together see Figure 1. Each rotor is supported on a shaft and when the pump is running within its operating limits, the rotors never touch the inside of the rotor case, or each other.

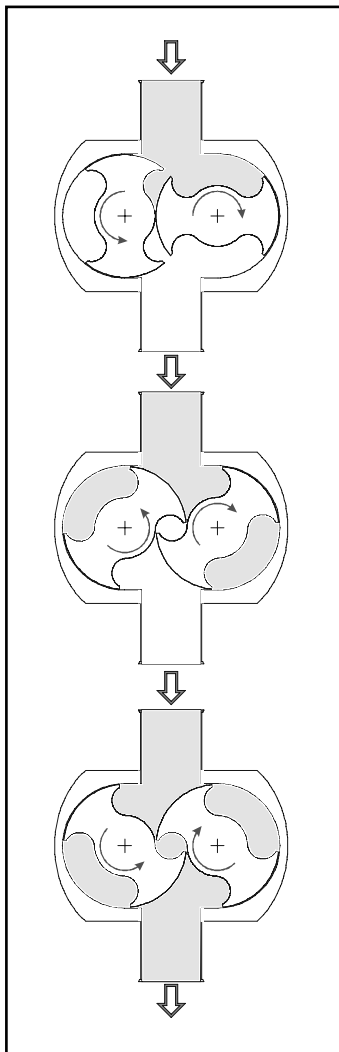

Figure 1  
Principle of  
Operation  
(Showing  
Vertical  
Mounting)

**1.03 OPERATING CONDITIONS**

Hy~Line and Ultima pumps are designed using modern design techniques and manufactured from high quality materials. However, there are certain limitations to the operating conditions of the pump to ensure long life and trouble-free running. During pump selection and specification these limitations are taken into account and must not be exceeded.

Every pump is supplied with a Performance Data Sheet which gives details of these limitations. These are:-

- Maximum **Pressure**
- Maximum **Temperature**
- Maximum **Viscosity**
- Maximum **Particle Size**
- Maximum **Speed**
- Maximum Input Shaft **Torque**
- Maximum Input Shaft **Radial Load**

These limitations and performance characteristics vary from one pump size to another, and from one pump specification to another within the same pump size.

Take particular care over the following:-

**Materials:** Ensure that all the fluids to be pumped, including cleaning and sterilizing agents, are compatible with the materials from which the pump is constructed.

See section 2.10 for details of shaft or seal types and section 2.11 for alternative seal materials, i.e. seal faces and elastomers.

Hy~Line and Ultima pumps can be used for duties other than those for which each pump was originally selected but the new application must be checked against the Performance Data Sheet to ensure safe and reliable operation. Unless you have experience in the use of this Data Sheet, we strongly recommend that, if a change of duty is required, you contact the distributor who supplied the unit or the manufacturer. Change of duty means changing any of the parameters listed above.

#### 1.04 MODEL NUMBERING SYSTEM

A metal plate is fixed to the pump showing model number and serial number.

The MODEL NUMBER gives important information about the specification of the pump, see Section 8 for details. It is important that the pump specification is established using Section 8 before any work is carried out on the pump or parts are ordered.

The SERIAL NUMBER is unique to each pump.

Both numbers should be quoted with all queries or orders for spares.

#### 1.05 INSPECTION UPON RECEIPT

All Hy~Line and Ultima pumps are factory inspected and tested before packing and shipping, to ensure safe delivery and satisfactory service. We would, however, recommend that you carry out the following actions upon receipt of your lobe pump:-

- a) Remove packing material from container and check contents against packing list. Look carefully for small parts and special tools included.
- b) Check the pump for any physical damage sustained in shipping. If loss or damage is found, notify your carrier and supplier immediately.
- c) Use lifting equipment as necessary when unpacking heavy items. See Performance Data Sheet for weights of bareshaft pumps. Drives and baseplates will increase weight above those shown.

## 2. INSTALLATION

Careful attention to correct installation of Hy~Line and Ultima lobe pumps, and recognition of certain limitations to the operating conditions of the pump, will ensure long life and trouble-free running.

 **Failure to follow these instructions could result in personal injury or loss of life.** Take particular care over the following:-

### 2.01 OPERATING LIMITATIONS

**PRIMING:** Hy~Line and Ultima pumps are not truly self-priming and should be installed in a “flooded inlet” pipe arrangement i.e. with the pump lower than the level of liquid to be pumped and with the supply pipe falling continuously to the pump with no loops.

**PRESSURE:** Do not operate the pump above the maximum differential pressure shown on the Performance Data Sheet, not even for a few seconds, as damage to the pump components will result, leading to metal particles in the pumped fluid, ineffective cleaning and possibly complete pump seizure.

 **NEVER** run the pump against a closed valve. Note that the pressure limit varies with temperature.

**SOLIDS:** Hy~Line and Ultima lobe pumps can handle soft solids in suspension but will be damaged by hard particles. Take care pumping solids, crystals, etc.

Never allow metal parts to enter pump, e.g. weld metal, screws, tools, etc. as these will stop the pump, leading to damaged rotors, rotorcase and shafts.

**CAVITATION:** The pumps cannot operate without sufficient pressure of liquid at the inlet port to supply the pump. Normally atmospheric pressure is sufficient but the actual pressure needed (Nett Inlet Pressure Required or NIPR), is higher for:-

- High Viscosities
- High Temperature
- High Pump Speeds
- Volatile Liquids

Insufficient inlet pressure will cause the pump to cavitate leading to low performance, noise and short pump life. Ensure inlet pipes are short, large bore and do not collapse under vacuum. Refer to Performance Data Sheet for Nett Inlet Pressure Required (NIPR) charts. If in doubt consult your supplier before operating the pump.

### 2.02 LOCATION & POSITIONING

Pump should be located:

- As close as possible to the fluid source and as low as possible to maximize the nett inlet pressure available to the pump.
- In a clear area allowing access all around pump and drive for easy servicing.
- With space above for lifting equipment if required.
- With port axis vertical if pump is required to be self draining.

All Hy~Line and Ultima pumps are equally suitable for both directions of rotation.

Hy~Line and Ultima lobe (not LH32 or LH34) pumps can be rotated to give vertical or horizontal port orientation with high/low or left/right input shaft positions. This is achieved with the bolt-on feet and re-positionable gear cover. (see Figure 2)

To change any pump from vertical to horizontal pipework or vice versa, a conversion kit containing the required feet and other components is available.

To convert a pump from high shaft to low shaft, it is necessary only to reverse the feet and timing gear cover positions as follows:-

### Foot Change

Remove key (29) from the drive shaft end. Remove the 2 bolts (18) from the gear cover (11) and slide the cover off of the shaft end, being careful not to damage the inside of the lip seal on the edges of the keyway in the shaft. Rotate the cover to the desired position and re-fit. It is wise to fit new sealing washers (19) to the heads of the bolts before re-fitting. Remove the 4 retaining screws (21) from the feet and re-position the feet in the desired position. Re-fit the bolts.

**For LH72, 74, 76 Pumps** - Replacement feet for vertical seal.

### For LH32 and LH34 Pumps:

The LH32 and LH34 size pumps are factory built with HORIZONTAL PORT orientation with top shaft position. They cannot be modified for alternative mountings. To enable VERTICAL PORT orientation it will be necessary to mount the pump on an angle bracket ('L'-Bracket). A special gear cover will be required.

Figure 2

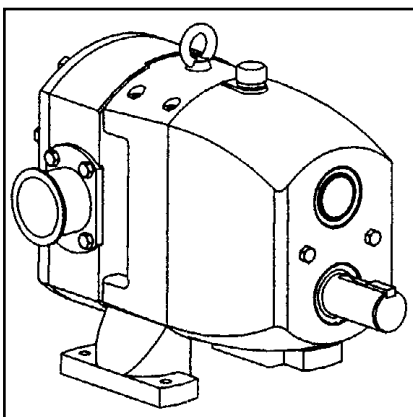

Horizontal Pipe Orientation,  
low shaft drive position

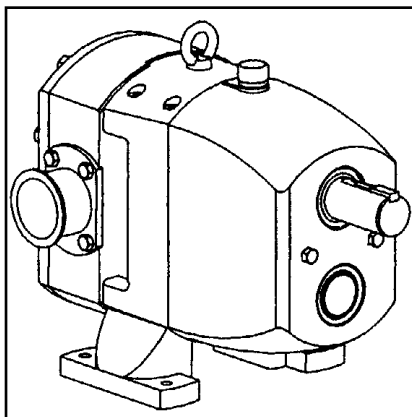

Horizontal Pipe Orientation,  
high drive shaft position

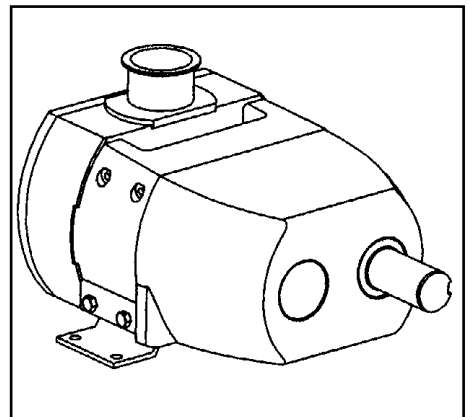

Vertical pipe orientation

## 2.03 DRIVES

Hy~Line and Ultima lobe pumps can be supplied in bareshaft form i.e. without a drive motor. Drives must be selected and supplied to suit each individual application. The prime mover will most likely be an electric motor but hydraulic or air motors may also be suitable.

Pay attention to special motor requirements.

- e.g.
- Explosion/flame proof
  - Hose proof/splash proof
  - High ambient temperature
  - Frequent stop/starts
  - Materials of construction

Provision of a variable motor speed (e.g. by frequency inverter), is always recommended to enable flow to be accurately set, to accommodate changes in fluid viscosity, temperature or required flow rate, or to run pump faster for cleaning. Variable speed motors must be selected to accommodate the full power and torque requirements throughout the operating speed range.

Transmission to the pump shaft will normally be by one of the following:

a) **Direct Coupling:** If synchronous motor speeds can be matched to the required pump speed, the drive can be via a proprietary flexible shaft coupling. A torque limiting coupling can protect the pump against overload.

In all cases the coupling manufacturer's limits should be adhered to. See Performance Data Sheet to calculate torque. Pump and motor shafts should be

accurately aligned in accordance with the coupling manufacturer's instructions.

Ultima **only:** When providing drives for Ultima pumps it is important to note that the rotors (57) are retained by tie-rods (26 & 27) which fit through the hollow shafts (24 & 25). Careful consideration should be made when installing drives and couplings so that access to the tie-rod nuts (87) and tie-rods is readily available for maintenance purposes. Use of a spacer type coupling is recommended.

b) **Reduction Gearbox:** For pump speeds lower than synchronous motor speeds, a proprietary gearbox or geared motor may be fitted. Variable ratio units are available to allow pump speed to be adjusted. Coupling to the pump will be as in (a) above.



Maximum shaft radial load stated on Performance Data Sheet must not be exceeded.

## 2.04 BASEPLATE

The pump and drive will normally be mounted on a common baseplate or frame which must be strong and rigid enough to withstand the drive reaction forces as well as to support the equipment without vibration. Ensure base is level - distortion could affect coupling alignment. Always check pump to drive alignment after installation and before starting pump. For maximum hygiene the pump feet should be sealed to the base.





## 2.05 GUARDS AND SAFETY

All moving parts must be guarded. Local safety regulations and codes of practice will specify the minimum acceptable standard but as a guide:

- Couplings, belts and pulleys must be enclosed to prevent fingers, clothing or tools from touching moving parts.
- Guards must be made from corrosion resistant materials.
- Guards in hazardous areas must be made from non -sparking material.
- Guards must be securely fixed.
- Pump must not be operated with guards removed.

 Ensure motor rating plate corresponds to supply.

 Ensure rating of motor and controls are adequate for duty, especially if application details have changed from original specification - see Performance Curves to calculate power.

 Allow for exceptional circumstances, e.g. cold start-up.

 Provide adequate motor overload protection.

## 2.06 ELECTRICAL

**Electricity can cause injury or death -** follow good practice and local regulations. In particular: -

 Connect electric motor in accordance with the manufacturer's recommendations.

 All electrical work must be carried out by competent personnel to local safety regulations and codes of practice.

 Take special note of requirements of the area, e.g. hose-down, high humidity, explosion proof, etc.

 Provide facility to isolate motor during maintenance, service and cleaning of pump.

## 2.07 PIPEWORK

Pipe runs and sizes should be established at the time the pump is selected. When installing pump do not deviate from this design without rechecking pump selection:-

- Keep pipe runs short and pipe diameters large; pipes may need to be larger diameter than pump ports especially when pumping viscous liquids.
  - Inlet pipe must be as short as possible and as large as possible to prevent cavitation.
  - Use large radius bends and full bore valves. Avoids globe or needle valves on viscous fluids.
  - Fit isolation valves each side of the pump to simplify maintenance.
  - Fit vacuum/pressure gauges each side of pump to monitor pressure conditions. Once process is established (and will not change), these can be removed.
  - Avoid filters on the inlet side of pump if possible. A clogged filter will cause cavitation. A strainer - maximum hole size 50 microns - will help to protect pump from damage by particles but must be kept clear.
  - Support pipework - do not allow weight of pipe (and the fluid within) to be taken on pump ports.
  - Fit expansion joints if necessary to prevent thermal expansion forces being transmitted to pump.
- Ensure all pipe joints are adequately sealed to be a) Air-tight under vacuum b) Liquid tight under pressure and c) Steam tight where applicable.
  - Take special precautions when pumping hazardous, hot, toxic or bacteriological fluids - special joints (e.g. aseptic) and high specification seals may be required.
  - Use hot water/steam jackets or electrical resistance tape to heat pipes carrying liquids which thicken when cool. Provide an interlock to prevent pump from running unless liquid in pipes is at correct temperature to avoid over pressure, cavitation. or excessive drive shaft loads.

## 2.08 ENLARGED RECTANGULAR INLET

The weight of the hopper (and the product it contains) must be supported separately and not allowed to rest entirely on the pump as this would affect the rotor clearances leading to pump seizure. The mating flange of a hopper or screw feeder should be machined to the identical dimensions of the rectangular inlet and sealed. This will avoid ledges where product could 'hang up'. Ensure effective flow of viscous material into the pump.

## 2.09 TEMPERATURE-CONTROL JACKETS

Pumps are available with an optional jacketed end cover (Pumps without end cover pressure relief valve fitted), pump head jackets fitted to top and bottom of endcover (can be used with end cover pressure relief valve) or jackets fitted to the sides of the rotor case (Hy~Line **pumps only**). These allow hot or chilled water, hot oil or steam to be piped to the pump to maintain product temperature in the pump or to heat the pump prior to starting.

Application limits are:

Jacket Pressure: 2 bar (30 psi).  
 Temperature: 130°C (265°F).

## 2.10 SEALS AND FLUSHING

Three basic types of mechanical face shaft seal are available on the Hy~Line and Ultima pumps. The correct type should have been selected when the pump was originally selected but you must establish that the seal fitted is suitable for the application before starting pump. (See Section 8.01 to identify seal type by pump model number). Provide flushing system as required.

There are also 3 types of seals which are not mechanical face type, these are the **Single O-ring seal**, **Double O-ring seal** and the **Multi Lip Seal**.

**Single O-ring Seals** utilise a single Viton O-ring on each shaft which are working under dynamic conditions. This type of seal requires a constant supply of pumped

product in order to avoid burning up of the O-rings by dry running. They do not require any additional services or special installation. If dry running will be experienced then the double O-ring seal should be used. See below...

The **Double O-ring Seal** is similar to the single O-ring seal, above, but have two Viton O-rings per shaft. They can be treated in the same way as a flushed mechanical seal i.e. will need the provision of a flushing system, See Flushed Mechanical Seals below.

An alternative to flushing the Double O-ring seal is to grease pack the area between the O-rings. This ensures that the O-rings can be run without product in the pump chamber i.e. run dry, as they will be lubricated by the grease. A method for 'topping up' the grease will be required e.g. grease nipples.

**Multi Lip Seals** are supplied complete with a grease injection system and require no additional services.

The **Single Mechanical Seal** is suitable for many clean fluids which do not require a more sophisticated seal type. (See Figure 3).

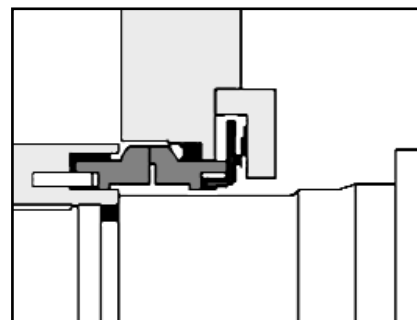

Figure 3:  
Single  
Mechanical  
Seal

Note that code 2, silicon carbide-on-silicon carbide, seals are not recommended for steam-purged applications as the seal faces can bind together - see Cleaning and Sterilizing.

Pumps fitted with single seals require no special installation but pumps must never be run completely dry for more than 30 seconds, as this will cause excessive heating of the seal faces. Use flushed seals in pumps that need to run dry.

The **Flushed Mechanical Seals** fitted to Hy~Line and Ultima pumps are run with a low-pressure liquid flush between the primary mechanical seal and a lip seal to form a barrier between the pump and the atmosphere. This allows the pump to be used for applications where the single seal is unsuitable.

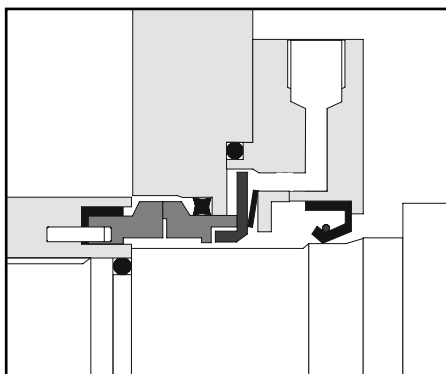

Figure 4:  
Flushed  
Single Seal

Flushed seals are used when:

- Pumped fluid changes state in contact with air, e.g. crystallises, forms a film, dries out or precipitates solids. The flush dissolves and rinses away the small amount of residue which could build up on the edges of the seal faces

- Pumped fluid is close to its boiling point e.g. water over 80°C (175°F). The flushing fluid is used to cool the seal faces.
- Pumped fluid is temperature sensitive and degrades when heated by the shearing action of the seal faces. The flushing fluid is used to cool the seal faces.
- Pump must run “dry”, i.e. no liquid in pump chamber.
- Pump is under high vacuum.
- A low pressure sterile barrier is required.

**A low-pressure flushing fluid system must be installed as follows:-**

- Liquid must be compatible with the pumped fluid; water is the most commonly used liquid.
- Pressure shall typically be 0.5 bar (7 psi) gauge. Maximum of 1.0bar (14.5 psi) gauge.
- Temperature shall be maximum of 70°C (160°F) for water, less for volatile liquids (maximum 20°C (68°F) below boiling point of liquid).
- Flow rate shall preferably be 2 to 3 litres/min. (0.5 to 0.75 US gal/min) per seal.
- Flush fluid should be connected to flow in at the lowest point on the seal housing and out at the highest point to vent air pockets.
- Pipework should be as shown in the diagram (see figure 4a).

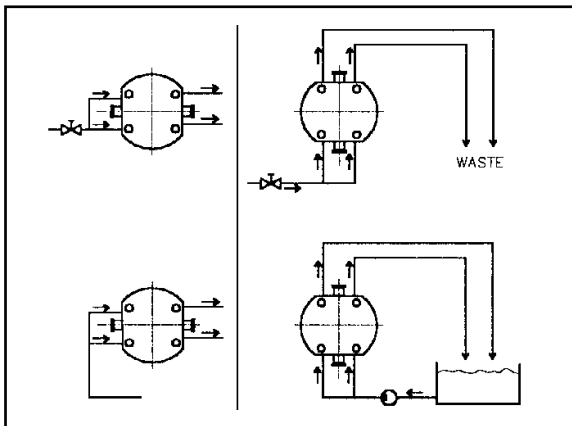

Figure 4a: Suggested Low Pressure Flushing System

The **double mechanical seals** fitted to Hy~Line and Ultima provide the facility to contain a high pressure fluid behind the primary seal. This allows the pump to be used for applications where the single seal is unsuitable. Double seals Codes 1 and 4 are run with a fluid between the primary and secondary mechanical seals to form a barrier between the pump and the atmosphere.

**For LH32 and LH34 Pumps:**

Double mechanical shaft seals are not available on the LH32 or LH34 size pumps.

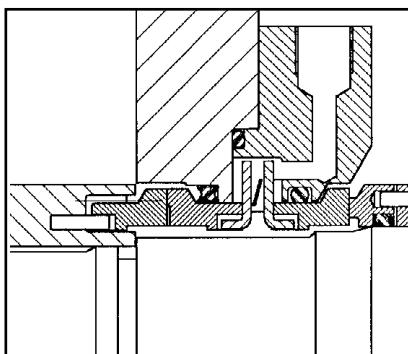

Figure 5:  
Double  
Mechanical  
Seal

They are used with:

**Double Mechanical Seal with a low pressure liquid flush when:**

- The pumped fluid is toxic or hazardous and must not escape from pump even in minute quantities.
- The system can be installed as in figure 4a but must be capable of withstanding the full pressure within the pumped fluid pipe system.

**Double Mechanical Seal with a high pressure liquid flush when:**

- The pumped fluid has no lubricating properties and cannot be allowed onto seal faces
- Pumped fluid is highly viscous, i.e. over 150,000 cps.
- A high pressure sterile liquid barrier is required.

When the double seal is used with a high-pressure liquid flush for the reasons described above, a flushing system must be installed as follows:

- The flushing liquid used must itself be compatible with the pumped fluid and must itself not require a complex seal, i.e. must be non hazardous, non abrasive and lubricating.
- Flush liquid must be at a pressure of 1 bar (15psi) above the discharge pressure of the Jabsco lobe pump and should flow at 35 to 55 litres/hour (10 to 15 US gal/hour) per seal.

- Flush fluid should be connected to flow in at the lowest point on the seal housing and out at the highest point to vent air pockets.

See drawing for suggested liquid flush system (see figure 5a).

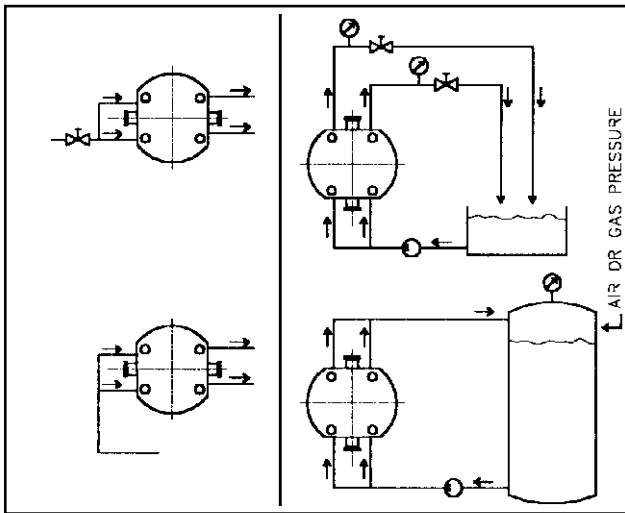

Figure 5a: High Pressure Liquid Supply System for Double Seals

**Double Mechanical Seal with steam when:**

No bacteria or contamination can be allowed to enter pump, i.e. an aseptic system. A steam barrier system must be installed as follows:

- Wherever possible, sterile liquid e.g. steam condensate should be used as a flush. Condensate should be connected to flow in at the lowest point on the seal housing and out at the highest point to vent air pockets.
- Where steam is essential, great care must be taken with the design of pipework, steam traps and controls.
- Steam must be clean, filtered and wet, i.e. not superheated.

- The pressure of steam should be as low as possible consistent with the desired temperature
- Steam should be connected in at the highest point on the seal housing and out at the lowest point to allow any condensate to drain from the lowest point
- See figure 6 for suggested steam connection.

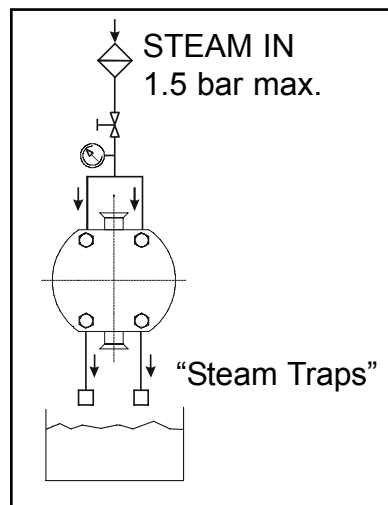

Figure 6: Steam Barrier Flush System For Double Mechanical Seal



Silicon carbide on silicon carbide seals are not recommended for steam flushed applications.

## 2.11 MECHANICAL SEAL MATERIALS

### SEAL FACES

All primary seals are available with carbon-on-silicone carbide faces (Codes 3, 4 or 5) for non abrasive fluids and silicon carbide-on-silicon carbide faces (Codes 1, 2 or 7) for abrasive fluids containing crystals, powders or particles or when no particles of wear can be allowed to enter the pumped fluid.

Silicon carbide-on-silicon carbide (Code 1, 2 or 7) seals are not recommended for steam flushed applications.

Hy~Line **only**: Carbon on stainless steel single seals (Code 8) are available for non-abrasive and lubricating fluids.

All secondary double mechanical seals (Codes 1 or 4) are with carbon on silicon carbide faces.

### ELASTOMERS

Product contacting primary elastomers must be selected to be compatible with the product and the process operation. Consideration must be given to chemical compatibility, temperatures and material standards. Hy~Line and Ultima are available in a selection elastomers, see below.

Hy~Line	Ultima
Nitrile- food grade	EPDM- FDA grade
EPDM- FDA grade	Viton- FDA grade
Viton- FDA grade	PTFE
PTFE	

Consult supplier for more information.

## 2.12 END COVER RELIEF VALVE

Hy~Line pumps can be fitted with an end cover relief valve which can be set to protect the PUMP ONLY from overpressure. This valve is not designed to protect the system or to provide long term by-pass of liquid. If this is required then an IN-LINE relief valve should be fitted which can by-pass the liquid back to the suction vessel during overpressure situations.

The maximum pressure rating of the pump is stated on the Performance Data Sheet. The relief valve should be set so that is fully open before it reaches this pressure. Be aware that there may be a piece of equipment in the system that is limited to a lower pressure than the pump. If this is the case then the pump end cover relief valve should be set so that the pump cannot exceed this pressure.

### Setting the relief valve :

This should be done, if possible, using the liquid to be pumped.

1. Screw the adjusting screw (135) clockwise so that enters the housing as far as possible. This ensures that the valve is fully closed.
2. A pressure gauge is required to be fitted in the pipe system directly after the pump.
3. Start the pump running.
4. Increase the pressure on the pump by closing a valve downstream or by increasing the pump speed. Continue until the desired relief valve pressure setting is achieved.
5. MAKE SURE THAT THE MAXIMUM PRESSURE OF THE PUMP IS NOT EXCEEDED. CHECK THE PERFORMANCE DATA SHEET.

6. Start unscrewing the adjusting screw (135) counter-clockwise until the pressure gauge reading starts to drop.
7. If a small rod/pencil/pen is inserted into the end of the adjusting screw until it contacts the end of the valve guide (134) it is possible to feel the movement of the valve.

**The valve is now set.**

8. Check the relief valve setting by opening the downstream valve or reducing the pump speed. It will be necessary to reduce the pressure to approximately 10% of the set pressure to ensure full closure of the relief valve. Alternatively stop the pump.
9. Re-start the pump or increase the pressure as before (see paragraph 4).
10. The relief valve should open at the set pressure.
11. Make further adjustments as necessary.

### 2.13 END COVER BARRIER (CODE 5)

Ultima pumps may also be fitted with an end cover to accommodate a barrier of sterile liquid or steam. This offers additional security when no bacteria or contamination can be allowed to enter pump, i.e. an aseptic system. (see figure 7)

**Liquid Barriers:** The flushing liquid used must itself be compatible with the pumped fluid. Fluid should be connected to flow in at the lowest point on endcover and out at the highest point to vent air pockets. Barrier fluid maximum pressure for the end cover is 2 bar. (see figure 8).

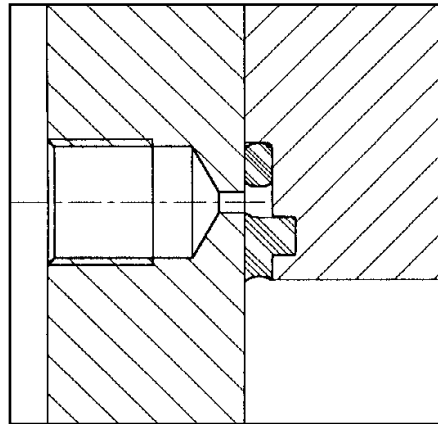

Figure 7:  
Ultima  
Barrier End  
Cover

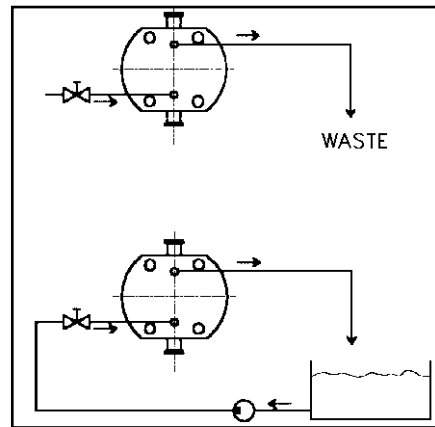

Figure 8 :  
Liquid  
Barrier  
System  
for Barrier  
End  
Cover

**Steam Barriers:** The pressure of steam should be as low as possible consistent with the desired temperature. Steam should be connected in at the highest point on the end cover and out at the lowest point to allow any condensate to drain from the lowest point. (see figure 6).

### 2.14 OVERLOAD PROTECTION

To prevent injury to personnel or damage to pump or system caused by excessive pressures, a protection device should be fitted such as:-



a) Pressure switch or sensor wired to stop the drive motor. Ideally, the motor should be fitted with a brake.

b) Pressure relief valve or bursting disc fitted downstream of the pump and piped to direct excess fluid away safely.

c) Pressure protection device fitted to pump end cover. Hy~Line pumps can be ordered with this already fitted or this can be ordered from your supplier and easily fitted in place of the standard pump end cover.

d) Torque limiting coupling between drive and pump shaft.

e) Motor current sensor.

**Note:** The level of protection provided by methods a) b) and c) above is superior to that provided by methods d) and e) which can be difficult to set accurately, especially when pumping viscous fluids.

Protection devices must be set to operate at, or below, the safe operating pressure of the pump or of the system, whichever is the lower. (See performance data sheet). Note that maximum pressure varies with temperature.

### 3. LUBRICATION

Jabsco Hy~Line and Ultima pumps have oil lubricated shaft bearings and timing gears.

 Pumps are supplied **without** oil in the bearing housing.

Before starting they must be filled with any of the following grades of oil, or equivalent gear oil for the relevant ambient temperature:

Ambient Temperature	Oil Grade
-18°C to 0°C (0°F to 32°F)	EP 150
0°C to 30°C (32°F to 86°F)	EP 220
30°C to 80°C (86°F to 180°F)	EP 320

Examples: Shell: Vitrea , BP: Energol CS, Castrol: Magna

Refer to Performance Data Sheet for oil capacity.

- After the first 120 hours of service drain the lubricating oil from the bearing housing and refill with fresh oil of the correct grade.
- Check oil level regularly and top up as necessary. Any substantial oil losses should be investigated immediately.
- Oil should be changed every 12 months or 2500 hours running.
- When pumping hot liquids or when bearing housing temperatures exceed 80°C (180°F) during operation use a high temperature synthetic oil and change oil every 6 months or 1000 hours running.

## 4. START UP & ROUTINE CHECKS

### 4.01 START UP

Before starting pump for the first time or after servicing or maintenance work, check the following - failure to do so could damage equipment or cause injury to personnel.

- All pump head and mounting bolts are tight.
- All pipe connections are secure.
- All guards, safety and protection devices, are in place and effective.
- Flushing fluid, if required, is flowing - see Section 2.10.
- All valves are open - **NEVER** run pump against a closed valve.
- Pipes and pump head, if heated, are to normal operating temperature.
- Pump and pipes are clear of welding flash or other debris.

**⚠ NEVER** use Hy~Line or Ultima pumps to flush the system the first time. Flush the whole system with suitable cleaning agents before starting the Hy~Line or Ultima pump, using another more suitable pump if necessary. Be aware that heavy or metal debris tends to collect at the lowest point in the system.

- Pump is correctly lubricated - see Section 3.
- Motor is wired for correct direction of rotation - see Figure 9.

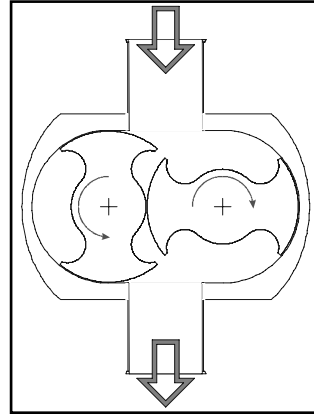

Figure 9.  
Direction of rotation - viewed from pump head. (Principles applies to all mounting orientations)

	DIRECTION OF FLOW			
	VIEWED FROM PUMP HEAD END		VIEWED FROM DRIVE SHAFT END	
DIRECTION OF DRIVE SHAFT	Clockwise	Counter Clockwise	Clockwise	Counter Clockwise
Horizontal Ports Top Shaft Drive	Left to Right	Right to Left	Left to Right	Right to Left
Horizontal Ports Bottom Shaft Drive	Right to Left	Left to Right	Right to Left	Left to Right
Vertical Ports	Bottom to Top (up)	Top to Bottom (down)	Top to Bottom (down)	Bottom to Top (up)

When possible, start pump slowly and increase speed gradually.

- Listen for unexpected noises.
- Check for leaks.
- Check that pump gives desired flow rate at normal operating speed.
- Do not continue to run pump if fluid is not flowing; dry running can damage seals - see Section 2.10.
- Observe pump during first few hours of operation - check for noises and excessive heating of pump bearing housing, i.e. if above 80°C (176°F), unless pumping hot liquids when 110°C (230°F) may be reached.
- If operating at high speeds or with hot liquids, surface temperatures can exceed 50°C (122°F), safety labels may be required to comply with local safety regulations.



All pumps and equipment surfaces which become hot, i.e. above 60°C (140°F), during operation should carry warning labels.

## 4.02 DAILY CHECKS

- Visual checks of all joints for signs of leakage of product, flushing liquid (if used) and oil from the gearbox.
- Listen and look for any unusual noises, vibration or temperature change.
- If minor problems are identified these should be rectified at the end of the shift and if major they should be attended to at once.

## 4.03 WEEKLY CHECKS

- As Daily Checks.
- Remove end cover of pump and inspect for signs of damage or wear. Repair or replace as necessary.
- If the main product shaft seals are of the O-ring type or multi lip seal type inspect them for signs of wear. Replace or plan for replacement as necessary.
- Check lubrication level and top up as necessary. This must be done with the pump stopped.
- Check lubrication level on drive unit and top up as necessary. Follow the manufacturer's instructions.

## 4.04 MONTHLY CHECKS

- As Weekly Checks.
- Remove end cover and rotors and inspect seal faces for wear and condition of elastomers. Replace as necessary or note for planned maintenance.

- If an end cover relief valve is fitted check its function. If the relief valve is not operating on a regular basis the diaphragm may have a tendency to stick.

## 4.05 SIX MONTHLY CHECKS

- As Monthly Checks.
- Change end cover O-ring (Hy~Line) or end cover gasket (Ultima).

## 4.06 ANNUAL CHECKS

- Possible change mechanical seals if fitted.
- Replace lip seal on mechanical seal flush housings.
- Replace end cover relief valve diaphragm.
- Change O-rings on O-ring type shaft seals or lip seals on Multi lip type shaft seals.
- Change all L-cups, O-rings and/or gaskets on pump head.
- Inspect gearbox oil seals and gearcover gasket for signs of leakage and replace as necessary.
- Check bearing wear by seeing if there is any movement of the shaft side to side or forwards and backwards. If movement is perceived remove gear cover and dismantle bearings for inspection, replace if necessary.
- Drain and change oil in pump gearbox.

*By ensuring a visual inspection daily and regular checks at planned intervals, pumps can be maintained to maximum performance for many years.*

## 5. CLEANING & STERILIZATION

Hy~Line and Ultima pumps are designed for use with products that require the process equipment and pumps to be cleaned. The standard (level) of cleaning or sanitization required depends on the needs of the process and product. This information is provided for guidance only. It is the responsibility of the pump user to satisfy him/herself that the cleaning protocol chosen is adequate to achieve the desired levels of cleanliness and Jabsco cannot accept any responsibility for contamination or loss.

In order to clean the pump it must either be dismantled (manual cleaning), or cleaned in place (CIP) as part of the procedure for cleaning the entire process. The higher the standard required, the more sophisticated the cleaning process. Hy~Line pumps can be cleaned and sterilised in place, i.e. by flushing through with cleaning agents and/or steam, without the need to dismantle pump. Equally the pump can be quickly stripped to gain access to all fluid contact surfaces for manual cleaning or inspection if required.

Ultima pumps offer an exceptionally high standard of in-place cleaning but are less suitable for manual (strip) cleaning.

### 5.01 CLEANING IN PLACE (CIP) AND MANUAL OR STRIP CLEANING

#### Cleaning Systems

The type of cleaning system used depends partly on the level of cleaning required but

also on what is to be removed. Organic materials such as oils, fats, proteins need a different system to inorganic materials such as mineral salts. Detergent manufacturers can give advice on the correct use of chemicals and temperature. CIP usually needs a velocity of 1.5 m/sec (5 ft/sec) through the pipeline to achieve the turbulent flow required.

#### Procedure For Cleaning In Place (CIP)

Each pump is supplied in a generally clean condition but it is the responsibility of the user to establish suitable cleaning and sterilizing regimes appropriate to the fluid and process. These should be implemented before the pump is first used and as often as require thereafter. The following guidelines will help with effective cleaning of both Hy~Line and Ultima pumps and minimise risk of damage to the pump.

1. Rinse through system with a suitable liquid, usually water at approximately 50°C (120°F), as soon as possible after completion of process to remove bulk of residues before they dry onto surfaces.
2. If CIP will not be carried out immediately after rinsing, leave pump and system full of rinse liquid.
3. Choose chemical cleaning agents to suit the nature of the contamination to be removed and use them in accordance with manufacturer's recommended dilution, temperature and circulation time but do not exceed 90°C (195°F). Confirm compatibility with pump materials of construction.

4. CIP fluid flow should result in a mean pipeline velocity of at least 1.5 m/sec. (5 ft/sec).

If using the lobe pump to circulate the CIP fluid, refer to the Performance Data Sheet for pump speed to give required flow, taking account of pressure losses through pipework. Note that all pumps are more susceptible to cavitation when pumping hot liquids. Ensure adequate Net Inlet Pressure available.

If using a separate pump to circulate CIP fluids, the lobe pump may need to be rotated at a speed sufficiently high to allow the fluid to pass freely through. If sufficient pipe velocity cannot be achieved, fit a by-pass loop to divert excess flow past the pump.

CIP fluid pressures must equal or exceed process pressure at all points in the system to ensure fluid reaches all contact surfaces. It may be necessary to restrict flow in discharge pipework to achieve this but do not exceed differential pressure and temperatures shown on pump Performance Data Sheet. A minimum differential pressure of 1 bar is recommended for effective cleaning.

5. After CIP, rinse through with neutralisers and clean water to remove all traces of cleaning agents.

 Do not pass cold liquid through pump immediately after hot - allow temperature to change slowly. Failure to observe can result in pump seizure.

## Procedure for Manual Cleaning

See elsewhere in this manual for procedures to dismantle and re-assemble fluid contact parts. Ultima pumps are not intended to be manually cleaned - Instead specify a Hy~Line pump which is designed to be stripped more easily for cleaning.

 Take care not to scratch or damage pump parts. One part of the seal face remains in the rotor when it is removed. Be extremely careful not to damage this seal face.

Do not use steel abrasive wool or brushes on fluid wetted surfaces as particles may become embedded in the surface and cause corrosion.

Use suitable cleaning agents in accordance with their manufacturer's instructions regarding temperatures, dilutions, skin contact precautions and other safety information. Thoroughly clean all fluid contact surfaces and rinse as required.

As a minimum it will be necessary to remove the end cover and rotors. Re-assemble pump in accordance with this manual.

## **5.02. STERILIZING IN PLACE**

It is possible to pass steam through the complete assembled system to sterilize the internal surfaces without dismantling the pump.

To achieve 100% sterility, it is important to steam through for a period long enough for the coldest part of the system to reach the correct temperature and hold for the time period required to kill off the organisms.

### **Procedure for Sterilizing In Place (SIP)**

If using chemical sanitizers, follow guidelines as for CIP above. If using steam, pump specification must be chosen at time of selection noting:

- EPDM elastomers offer best resistance to repeated steam contact but will need to be changed periodically.
- PTFE (Teflon) is least suitable for steam contact - PTFE end cover joints may need to be replaced every time the pump is sterilized.

Pump should be mounted with the port axis vertical to avoid collecting liquid pools.

1. Thoroughly clean pump and process lines prior to sterilization.
2. If pump is fitted with sterile barriers (on seals, end cover) for the purpose of maintaining sterility, barrier fluid must be connected throughout SIP cycle to avoid re-infection.
3. Pass clean, wet steam through system until all component temperatures have stabilised. Steam must be free of scale, rust and particles - a filter may be necessary. Typically steam will be at 121°C (250°F) and 1 bar (15 psi). Soak time, to bring the pump up to temperature,

is typically 20 minutes but this should be established, e.g. using thermocouples, as the required soak time will vary with individual installations.



Do not rotate the lobe pump during this heating phase.



Do not loosen or remove any pump components or pipe connections during steam sterilisation as escaping steam may cause serious injury.

4. Continue to pass wet steam through the lobe pump and process lines during the hold time. Hold time will be determined by the user to achieve desired level sterility. Typically this will be between 20 and 60 minutes.

The lobe pump should not be rotated during this hold time unless absolutely essential to achieve sterility, due to increased risk of pump seizure. All pump components will normally reach desired temperature by thermal conduction without rotating the pump.

If essential, the lobe pump can be rotated by hand during hold time - beware of danger of hot surfaces - or at a maximum of 50 rpm but only if the pump is fitted with either:  
 Single carbon/silicon carbide seals (Code 3) - or - Flushed or double seals (codes 1, 4, 5 or 7) provided a liquid flush, e.g. condensate, is connected and operating at a pressure above the steam pressure within the pump during SIP.

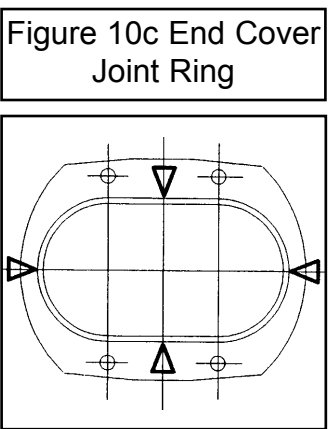
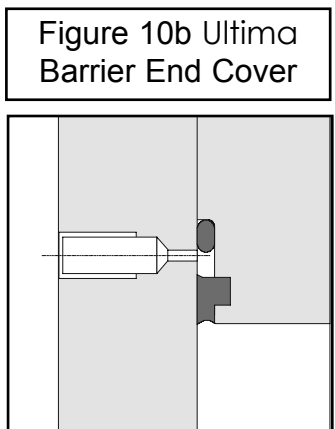
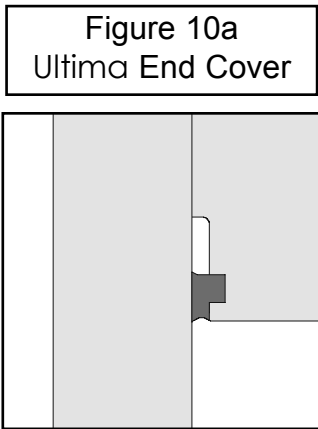
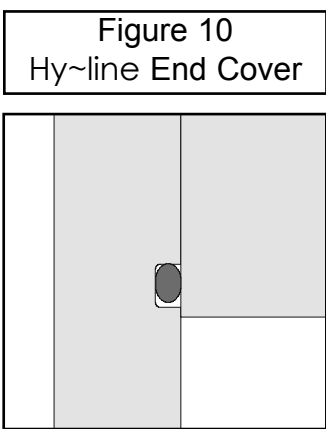

**!** If the lobe pump is fitted with single silicon carbide/silicon carbide seals (Code 2) it **must not** be rotated during hold time as the seal faces can bind together.

5. At the end of hold time, pump must be allowed to cool naturally or can be purged with sterile air/inert gas.

**!** Pump must not be rotated during cooling.

6. Do not allow cool liquid to enter the lobe pump before pump temperature has fallen to 60°C (140°F) or lower.

If the pump is fitted with silicon carbide/silicon carbide seals (Code 1, 2 or 7), flood it with liquid to lubricate the seals before rotating it.

## 6. INSPECTION AND REPAIR

Hy~Line and Ultima pumps need no adjustment during normal operation. It is advisable though to check oil levels and inspect pump head components (especially seals and joints) periodically so that they may be cleaned or replaced before they fail in service.

All primary fluid contact components of the pump can be inspected and serviced without removing the pump rotor case from the bearing carrier and without removing either the pump or drive unit from the baseplate, as follows:-

**!** **For your safety:**  
Before commencing any repair or inspection, isolate power to pump and drive motor, depressurise, drain and isolated pipework, seal flush and temperature control jackets (if fitted).

### 6.01 END COVER (see figures 10, 10a, 10b and 10c)

#### Removal

Before removing the end cover (122), ensure the pump & drive are isolated, the pump is cool enough to safely touch, drained of any fluids (take special care with hazardous fluids) and ensure that pump, seal flushing system and jackets are isolated and depressurised.

If end cover is fitted with a pressure relief valve refer to the relevant section 2.13. Then proceed as follows:-

 **ATTENTION:** The end cover is heavy, take care to support it when removing the bolts (123).

- a) Remove bolts (123) and remove cover. If it is stuck tap carefully sideways with a soft hammer, do not lever off.
- b) Do not damage face of cover or joint ring(s); place face upwards on a clean surface.

### Re-fitting:-

- a) Hy~Line **only:** Place the O-ring (120) in the end cover groove, ensuring that it seats evenly .
- a) Ultima **only:** Fit end cover joint ring (121) in rotor case as figure 11a & 11b. Press in, in 4 places first, see figure 11c, then press in the rest to avoid forming loops.
- b) To refit, reverse the procedure, ensuring the end cover is correctly located on rotor case before tightening screws to the correct torque. (See performance data sheet).

## 6.02 ROTORS

### Removal

Disconnect pump from motor drive. Remove end cover - see section 6.01.

- a) Hy~Line **only:** The rotors are secured by special slotted screws (59) sealed by O-rings (58). Lock the pump rotors with a soft spacer - a plastic block (180) is provided for this purpose. (see also figure 11). Use only the special tool (181) supplied to loosen and retighten. Both screws have a right-hand thread.

Withdraw rotors carefully to avoid seal damage by contact between shaft ends and seals faces which are located on the back of the rotors.

- a) **LH72, 74, 76 & Tanker Pumps:** Lock the pump rotors with a soft spacer - A plastic block (180) is provided for this purpose (see also Fig.11). Use only the special tool (181) supplied to loosen and retighten the hygienic cap (59A) both screws have a right-hand thread. Remove the three bolts holding the rotors onto the shaft using an allen key. Withdraw rotors carefully to avoid seal damage by contact between shaft ends and seal faces which are located on the back of the rotors.

- a) Ultima **only:** The rotors in Ultima pumps are held in place with tie-rods (26 and 27) which have threaded ends and pass through the hollow shafts (24 and 25). The tie rods are secured with nuts (87) and washers (88). To remove rotors proceed as follows:

Lock the pump rotors with a soft spacer - a plastic block (180) is provided for this purpose. See also figure 11. Loosen and remove tie-rod nuts (87) and washers (88).

Push the tie-rod (26 & 27) through the shaft to release the rotors (57) from the shafts (24 and 25). A soft mallet may be used on the end of the tie-rod, however care must be taken not to damage the thread.

Once the rotor and tie-rod are removed from the shaft the rotor (57) can be removed by unscrewing it from the tie-rod (26 and 27) which should be held in a soft jaw vice. Ensure that the tie-rods



are kept with correct rotor and shaft.

- b) Keep each rotor with its respective shaft to ensure correct mating of sealing faces on re-assembly - you may wish to mark or label the components at this stage.
- c) Take care not to damage the rotors and especially the smooth face of the mechanical seal (80) which is pressed in the back. Do not attempt to remove the seal unless you intend to fit a new seal (80) or cup rubber (83).

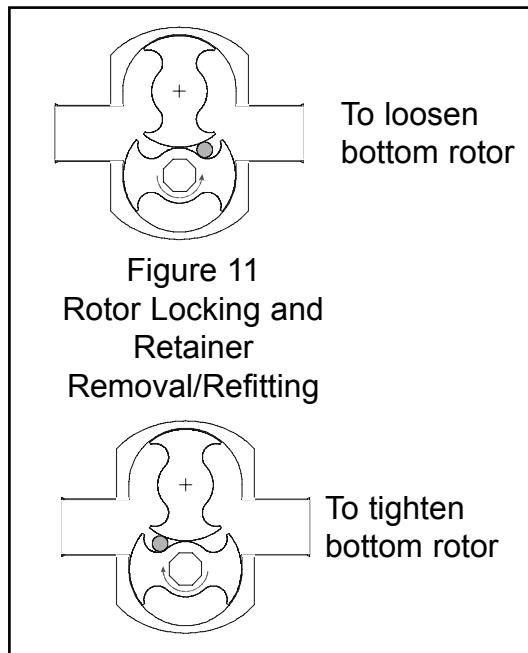

Figure 11  
Rotor Locking and  
Retainer  
Removal/Refitting

### Re-fitting:

- a) With the seal and cup rubber correctly fitted within the back of the rotor, clean and dry the seal faces with a soft tissue before re-fitting. Do not lubricate seal faces.
- b) Slide the rotor assemblies into their respective shafts. When fitting each rotor it should slide freely on its drive splines. (LH72, 74, 76 & Tanker pumps - Locate rotors on pin)

c) Hy~Line **pumps** - refit the O-ring (58) to the rotor screw (59) and lubricate the bore in the front of the rotor. Lock the rotors using a soft spacer and refit the screw. Retighten using the special tool provided to the torque specified in Figure 11a.

c) **LH72, 74, 76 & Tanker Pumps** - Lock the rotors using a soft spacer and re-fit the three rotor bolts to torque specified in Fig.11a. Re-fit the O-ring (58) to the hygienic cap and lubricate the bore in the front of the rotor. Retighten using the special tool provided to the torque specified in Figure 11a.

c) Ultima **pumps** - secure the tie-rod with the washer and nut. Lock the rotors using a soft spacer and tighten nut to the torque specified in the Performance Data Sheet.

Pump Size	Torque
LH/LU 32/34	18NM
LH/LU 42/44	55NM
LH/LU 52/54	55NM
LH/LU 62/64	100NM
LT62/64 (tri-bolt)	Hygienic Cap 20NM Bolts 25NM
LH72/74/76 (tri-bolt)	Hygienic Cap 40NM Bolts 50NM

Figure 11a

### 6.03 MECHANICAL SHAFT SEALS – SINGLE SEAL & PRIMARY SEAL OF A DOUBLE SEAL

When the rotors have been removed (see Section 6.02) the primary seals can be inspected for wear, cracks, chips, scratches or signs of burning caused by running dry.

Inspect rubber joints for damage or deterioration. Clean the seal faces with soft lint-free tissue before re-assembly.

It is advisable to purchase and fit new elastomer trim kits from your local distributor, when removing and re-fitting seal

faces. As a precaution it is also advisable to have a spare set of seal faces available as these parts are very brittle and are easily broken.

**To dismantle mechanical seals:**

a) Carefully remove the static seal seats (80) from their bores in the rotor case (51), by inserting the special seal removal tool (182) carefully between the outside diameter of each seal seat and the bore in the rotor case. Push back the joint ring with the end of the tool and rotate the tool by 90 degrees, until the hooked end locks in position behind the seal seat. Working the tool gently around the circumference of the seal, carefully pull the seal face out. (See figure 12) Take great care not to scratch or damage the smooth face of the seal. Keep each seal with its respective shaft to ensure correct mating of the seal faces on re-assembly.

b) The joint ring (83) may come out with the seal face. If not, then remove it from the rotorcase bore and keep it together with the seal face. You may wish to label the components.

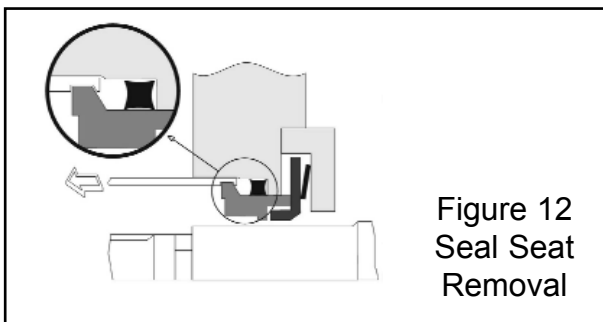
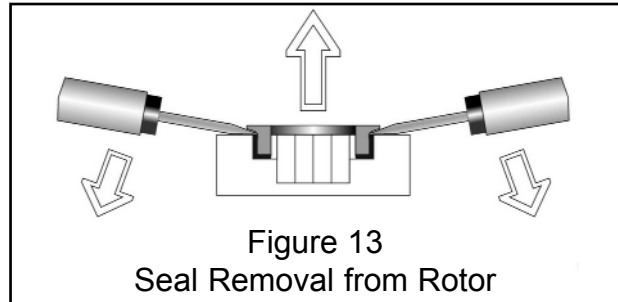

Figure 12  
Seal Seat  
Removal

**Note:** static seal seats can also be accessed from the back of the rotorcase after removing the rotorcase and seal housings (see section 6.06).

c) Only remove the rotary seal seat (80) from the back of the rotor (56 & 57) if you intend

to fit a new seal or cup rubber (83). Gently prise out the seat from the rotor using two blunt screwdrivers. (See figure 13). Seat materials are brittle, eye protection is recommended.



**For LH32 & LH34 Pumps**

**Note:** Double mechanical shaft seals are not available on the LH32 or LH34 size pumps

a) Pull the static faces (80) from their bores in the rotor case (51), removing the joint ring (83) with each seal face. Take care not to scratch or damage the smooth face of the seal. If you intend to re-use these faces keep each seal with it's respective shaft to ensure correct mating of mating of seal faces on re-assembly - you may wish to label the components.

b) Only remove the seal seat from the back of the rotor (56 & 57) if you intend to fit a new seal or cup rubber (83)

Make up or purchase a sleeve as shown in Fig 13a. Press sleeve down onto visible edge of the cup rubber. This will force the rubber down into the seal bore in the rotor. The seal face will be pushed out of it's bore. Do not lever out the seal face with screwdrivers or similar tools as seal materials are brittle and are easily damaged or broken. Eye protection is advised. If the

seal face is to be re-used, note which way up it was fitted - seal faces are not reversible.

Figure 13a

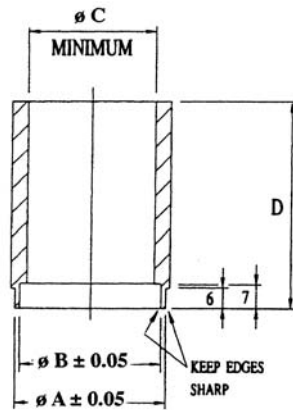

A	B	C	D
42.85	40.1	31	60

Dimensions in mm

**To Re-assemble Mechanical Seals:**

**Note:** if refitting previously used seal faces ensure that rotary and static faces are in their original pairs.

 Fit the seal face with the narrow face track into the rotorcase. The seal face with the wide face track should be fitted into the rotor.

- a) Fit the joint ring (83) to static primary seal face and lubricate bore in the rotor case with a suitable lubricant compatible with the pumped fluid and the elastomer. Do not use mineral-oil based lubricants on EPDM joints.
- b) Align slots in seal face with 'dogs' of drive plate in seal housing; a small cut-out is provided so one drive dog can be seen (See figure 14). Push each seal seat in straight; when correctly fitted, seal seats should slide freely against the resistance of their springs.

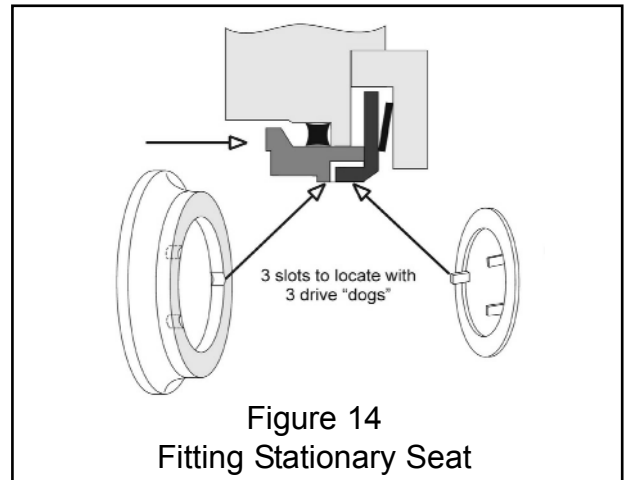

Figure 14  
Fitting Stationary Seat

Undue pressure is not required or recommended as seals are precision components. Be sure not to damage the joint ring (83), if difficulty is experienced put the joint ring into the rotorcase bore then push the seal seat into the bore.

**Note:** if the rotorcase has been removed (see section 6.10), static seal seats should be inserted into the rotorcase, before mounting the rotorcase onto the bearing housing.

c) To fit seal seat to rotor (56 & 57), first insert cup rubber (83) into the rotor (do not lubricate), ensure alignment with drive pin. (see figure 15). If PTFE trim is fitted, insert the rubber washer first followed by the PTFE sleeve. Note that the sleeve is slightly tapered and will be easier to fit if the narrow side is inserted first. Then lubricate outside diameter of seal seat. (do not use mineral-oil based lubricants on EPDM joints) Align drive pin with one of the three slots in seal seat. Engage the leading edge of the seal seat into the cup rubber or PTFE sleeve. Push down evenly until seal seat rests squarely on bottom of seal bore in rotor. Do not damage seat face. When correctly fitted,

the seat is parallel with the back face of the rotor and must not be tilted. Any "run-out" of the seat will cause leakage of the seal. Assembly of the seal is now complete.

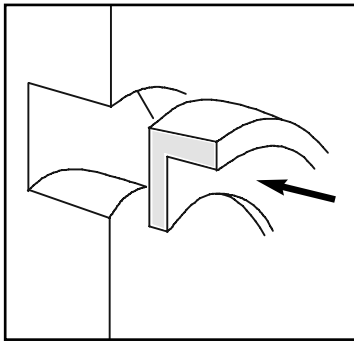

Figure 15 Cup Rubber Insertion in Rotor

Carefully clean all seal faces with a soft lint-free cloth and to remove all dust and grease. It may be necessary to use a compatible solvent to remove oil or grease.

It is not normally necessary to remove the seal housings (86) from the back of the rotor case except to check condition of springs (82) and drive plates (81). If re-fitting seal housings, align the 3 slots in outer edge of drive plate with the 3 pins. When fitted, ensure drive plate can slide freely against spring pressure. (See section 6.06).

**For LH32 and LH34 pumps:**

a) Check the coil springs are in place in the seal housings. Fit the joint ring (83) to the seal face and lubricate the bore in the seal housings with a suitable lubricant compatible with the pumped fluid and process. Do not use mineral-based lubricants on EPDM elastomer joints; silicone grease is suitable.

b) Align one slot in the rear of the static seal face with the pin in the seal housing and push the face back firmly against the coils springs. It should be free to 'spring' backwards and forwards.

c) To fit the seat to the rotor, first fit a new cup rubber (83) to the seal face. Ensure the seal face is the correct way round, ie the smooth working face exposed. Note - the back (non-working) face of the seal is identified with a groove or white mark.

d) Lubricate the outside diameter of the cup rubber with a suitable lubricant (as para.a) above), and press the face evenly into the rotor. Use a soft sleeve made from Nylon as shown in Fig 13b and fit it into the end of the tool as shown in Fig 13a, or use your fingers to do this in order to avoid damage to the seal face. When correctly fitted the seal face should be 'flush' with the back face of the rotor and **MUST NOT** be tilted. Any 'run-out' of the seal face could cause seal leakage. The cup rubber **SHOULD NOT** stand 'proud' of the back face of the rotor.

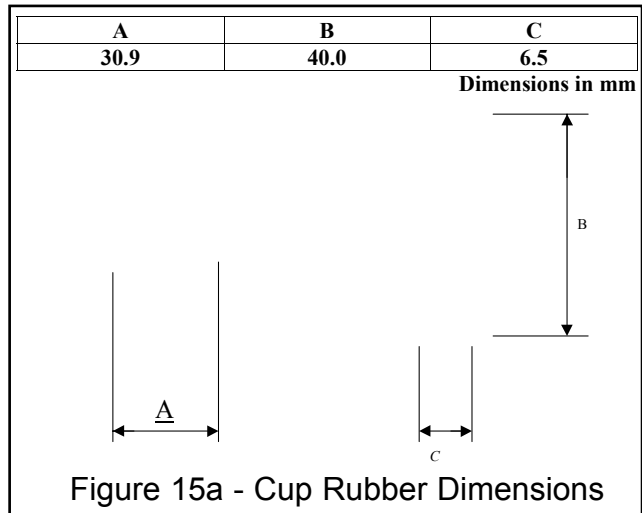

Figure 15a - Cup Rubber Dimensions

**6.04 SHAFT SEALS - SINGLE FLUSHED**

Pumps fitted with flushed seals have lip seals fitted in order to retain a flushing or barrier fluid. To service lip seals it is necessary to remove the rotor case (51) - see section 6.04 - Then proceed as follows:

**Removal:**

- a) Remove seal housings (89) from back of rotor case. (See section 6.06).
- b) Press lip seals out of housings.
- c) Check that surface of shaft where lip seal runs is smooth and is not grooved.

**For LH32 and LH34 models:**

Check that the surface of the sleeve where the lip seal runs is smooth and not grooved. If necessary replace the sleeve by lightly heating the sleeve to break the bond of the adhesive and then, with a flat bladed screwdriver, prising the sleeve off the shaft.

**Re-assembly:**

- a) Push new lip seals into housings. Assemble spacer collar, wave spring and drive plate as shown on figure 16. (Also see section 6.06).
- b) When re-fitting seal housings, align the 3 slots in outer edge of drive plate with the 3 pins. When fitted, ensure drive plate can slide freely against spring pressure.
- c) You may wish to insert the joint ring (83a) and static primary seal seats at this point (see section 6.03).
- d) When re-fitting rotor case to bearing housing, take care that lip seals and mechanical seals (80) are not damaged by the shaft splines or shaft ends.

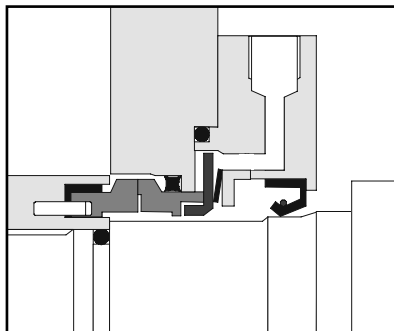

Figure 16  
Single  
Flushed  
Mechanical  
Seal

**Re-assembly:**

- a) Push new lip seals into the seal housings.
- b) Fit the O-rings into the grooves in the outside diameter of the housings
- c) Assemble the seal housings (89) into the rear of the rotor case (51) and clamp in position using the six clamp washers (84) and screws (85).
- d) If the shaft sleeves have been removed, fit new sleeves. These need to be glued to the shaft by spraying the area of the shaft where the sleeve is to fit and also the inside bore of the sleeve itself with LOCTITE™ Activator 7471. Then smear a generous amount of LOCTITE™ 635 to the area of the shaft where the sleeve is to fit. Slide the sleeves onto the shafts up to the shoulder on the shaft, note that the sleeve cannot be pushed fully against the shoulder because of the radius in the corner. The sleeve should be fitted with the chamfered end towards the front of the pump. Rotate the sleeve on the shaft to ensure that the LOCTITE™ forms a seal as well as a bond. Leave for 5 minutes to allow the bonding process to occur.
- e) Continue by following the instructions in section 6.06 for assembly of the mechanical seal.

## 6.05 SHAFT SEALS - DOUBLE MECHANICAL

(See section 6.03 for servicing of primary (product) seal face.)

Pumps fitted with double seals have secondary seals in order to retain a flushing or barrier fluid. To service primary seals see section 6.03. To service secondary seals it is necessary to remove the rotor case - see Section 6.10 - Then proceed as follows:

**Note:** Not available on LH32 and LH34 pumps.

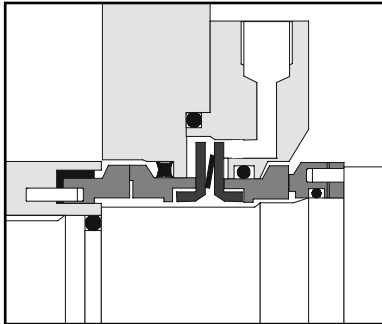

Figure 17  
Double  
Mechanical  
Seal

### Removal:

- Remove static faces from housings. (95)
- If fitting new O-rings (93) prise them out of the housing (95).
- Pull rotary seats (92) off of their shafts. Take care not to scratch or damage the smooth faces of the seals. Keep each seal with its respective shaft to ensure correct mating of seal faces on re-assembly - you may wish to label the components at this stage.
- If fitting new O-rings (93) prise them out of their seal face (92). It is not normally necessary to remove the seal housings (86) from the back of the rotor case except to check condition of springs (82) and drive plates (81) (See section 6.06).

### Re-assembly:

- To re-assemble, place O-ring (93) in double seal housing (95), lubricate outside of static seat with a suitable lubricant compatible with the barrier fluid. Align slots in seal face with dogs of drive plate (81) in seal housing (see figure 15) and push seat fully in. The seat should slide freely against the plate (81) and wave spring (82).
- If fitting double seals to a pump for the first time, e.g. retrofitting a single seal pump, gently tap or press the support ring (92) square up against the shoulder on each shaft.
- Fit soft washer (92a) in place on support ring.
- Fit O-ring (93) to rotary seal seat (92). Gently push seal seat squarely on to shaft, aligning hole in rear of seal face with pin on the support ring.
- Clean seal faces with soft lint-free tissue to remove any grease or dust - do not lubricate. Refit rotor case taking care that shafts do not damage secondary seal faces. (See section 6.10)

## 6.06 SEAL HOUSINGS

It is not normally necessary to remove the seal housings (89 or 95) from the back of the rotor case except to check condition of springs (82) and drive plates (81). If required to do so, proceed as follows:

**Note:** Seal housings vary for single (86), flushed (89) & double seals (95) (See section 2.10).

**Removal:**

a) Remove end cover (see section 6.01), rotors (see 6.02), rotorcase (see 6.04).

b) Position rotorcase (51) face down on a clean smooth surface, seal housings (89 or 95) uppermost. Taking care not to damage the front of the rotorcase.

c) If double seals are fitted remove static seal seats (92) from the housings (95), keeping mating seal faces together. You may wish to label the components. (See section 6.05).

d) Loosen screws (85) by half a turn and rotate excentric clamp plate (84) by half a turn. Carefully withdraw the seal housings. Note the position of drive plates, wave springs and backing rings.

e) Inspect components for wear, replace as required.

**Re-fitting:**

For single flushed seal housings refer to section 6.05 for lip seal replacement.

a) **Single or Single Flushed Seal** - Assemble wave spring (82) followed by drive plate (81). Ensure that the 3 slots on the outer edge of the drive plate locate on the 3 pins in the housing. Drive plate should be assembled with drive 'dog' side last.

a) **Double Seal** -Assemble one drive plate (94) with drive 'dog' side entering first and the 3 slots on the outer edge locating on the 3 pins in the housing. Assemble wave spring (82) followed by the second drive plate (81). Ensure that the 3 slots on the outer edge of the drive plate locate on the 3 pins in the housing. Drive plate should be assembled with drive 'dog' side last ie opposing direction to first drive plate.

b) For flushed or double seals, position O-ring (91) on to the step on the outside diameter of the seal housing.

c) Holding seal housing (86), drive plate(s) (81 & 94) and wave spring (82), together; position housing assembly into bore on back of rotorcase to fit flat with rear face of rotorcase.

d) Hold in position and rotate clamp plates (84) half a turn in order to retain the housing. Tighten screws (85) finger tight only

e) Ensure drive plate(s) is free to move. Tighten housing screws to correct torque.

**6.07 SINGLE O-RING SEAL****(Hy~Line Option only)**

This seal is designed such that it can be maintained without removing the rotor case. It will be necessary to remove the end cover to gain access to the seals.

**Removal :**

a) Remove the rotor retaining screws (59), being careful not to lose the O-rings (58). Withdraw the rotors from their shafts. The rotor has a small sleeve (96) inserted into the rear face, this should come out together with the rotor. If it does not then it will be necessary to remove this sleeve from the rear of the rotor case.

b) Remove the sleeve from the rotor and the O-ring (99) from the groove in the sleeve.

c) To replace the dynamic O-ring (100) simply pull it out from the bore in the rear of the rotor case.

d) If it is necessary to replace the seal housing (97) or O-ring (101) loosen the nut (98) until it disengages with the housing. Pull the housing out from the front of the rotor case and remove the O-ring from it's groove.

**Re-assembly:**

a) If the housing (97) has been removed, refit a new O-ring (101) to the groove in the outer diameter of the housing.

b) Lubricate the O-ring and slide the housing into the rear of the rotor case until it engages with the retaining nut (98). Tighten the nut.

c) Fit a new O-ring (99) into the groove in the sleeve.

d) Lubricate the O-ring and slide the sleeve (96) into the rotor. Make sure the drive pin in the rotor is located in the hole in the sleeve.

e) Lubricate the dynamic O-ring (100) and fit into the seal housing.

f) Slide the rotor onto the shaft ensuring that the leading end of the sleeve slides smoothly through the dynamic O-ring.

g) Re-fit the rotor retaining screw and O-ring to the rotor and tighten to the correct torque (See Performance Data Sheet).

**6.08 Double O-Ring Seal****(Hy~Line option only)**

This seal is designed such that the primary dynamic O-ring can be replaced without removing the rotor case. It will be necessary to remove the end cover to gain access to the seals. Before disassembling the seal ensure that the flushing system, if fitted, is switched off.

**Removal :**

a) Remove the rotor retaining screws (59), being careful not to lose the O-rings (58). Withdraw the rotors from their shafts. The rotor has a small sleeve (97) inserted into the rear face, this should come out together with the rotor. If it does not then it will be necessary to remove this sleeve from the rear of the rotor case.

b) Remove the sleeve from the rotor and the O-ring (99) from the groove in the sleeve.

c) To replace the dynamic O-ring (100) simply pull it out from the bore in the rear of the rotor case.

d) If it is necessary to replace the seal housing (104), secondary dynamic O-ring (100) or housing O-rings (102) it will be necessary to remove the rotor case (51). See section 6.10

e) Once the rotor case has been removed the 4 bolts (83) can be removed and the flushing housings (104) withdrawn.

f) The seal housings (97) can now be withdrawn from the rear of the rotor case.

g) The O-rings (102) can be removed from their grooves on the outside of the seal housings and the secondary O-rings (100) removed from the inner bore of the housings.

**Re-assembly:**

a) If the housings (97) have been removed, refit new O-rings (101 & 102) to the grooves in the outer diameter of the housings and a new secondary dynamic O-ring (100) to the groove in the inner bore of the seal housing.

b) Lubricate the outer O-rings and slide the housing into the rear of the rotor case.



- c) Fit new O-rings (103) into the recesses in the rear face of the rotor case and re-fit the flushing housings.
- d) Fit and tighten the 4 retaining bolts (83)
- e) Fit a new O-ring (99) into the groove in the sleeve.
- f) Lubricate the O-ring and slide the sleeve (96) into the rotor. Make sure the drive pin in the rotor is located in the hole in the sleeve.
- g) Lubricate the dynamic O-ring (100) and fit into the seal housing.
- h) Slide the rotor onto the shaft ensuring that the leading end of the sleeve slides smoothly through the primary and secondary dynamic O-ring (100)
- i) Re-fit the rotor retaining screw and O-ring to the rotor and tighten to the correct torque (See Performance Data Sheet)

**6.09 Multi-Lip Seal**

**Under development, details to follow shortly.**

**6.10 ROTOR CASE**

Disconnect process pipes and any flush/barrier connections, first ensuring fluid is not under pressure. The rotor case can be removed after withdrawing the end cover (see section 6.01), the rotors (see section 6.02) and the four hexagon socket screws (52) holding the rotor case (51) to the bearing carrier (1). Note that the rotor case is dowelled and can only be re-fitted one way round.

 Secure the pump onto a workbench or baseplate before removing the rotorcase, as the gearbox will tip backwards without the rotorcase being in position.

 The rotorcase is heavy, ensure that it is supported before the four hexagon socket screws are removed.

If primary or secondary static seal seats (80) are still fitted to the rotorcase take care not to damage them on the shaft ends (24 & 25). If single flushed seals are fitted take care not to damage them on the shaft splines or shims (30).

To re-fit, reverse the above procedure. Torque the four hexagon head socket screws (52) to the correct setting. (see Performance Data Sheet).

**6.11 ROTOR CLEARANCE - ADJUSTMENT**

Hy~Line and Ultima pumps have very small, carefully controlled clearances between rotors and rotor case - see Performance Data Sheet for specific details. If the end clearances are incorrect they can be adjusted. The other clearances- rotor to rotor (Y) and rotor tip to rotorcase bore (Z) factory set and cannot be adjusted. See figure 18.

**Note:-** Shims on tri-bolt fit inside rotor!

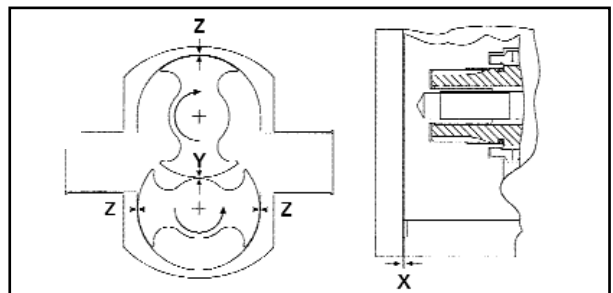

Figure 18 - Shim / Clearance Measuring

- a) With the pump assembled, the end cover (122) removed and the rotors (56 & 57) and rotorcase (1) fully secured to the correct torques. Measure the rotor front end clearances (X) using a depth gauge or feeler gauge and straight edge.
- b) If the clearance is incorrect, remove the rotors (56 & 57) see section 6.02. Remove the O rings (31) and shims (30), the shims are cut to allow them to slide over the shaft. Tri-bolt shaft shims are uncut.
- c) If mechanical shaft seals are fitted take great care not to scratch, chip or damage the seal faces.
- d) Measure the thickness of the shim pack for each shaft and calculate the thickness of shim to add or remove on each shaft to give the front clearance specified in the Performance Data Sheet. Shims are available in increments of 0.025 mm (0.001 inch). (See Figure 18).
- e) To fit the shims open them slightly and slide onto the shaft up to the shoulder (A) - see figure 19. NOTE: New shims are not cut, this will need to be done with scissors prior to fitment. **(LH32 and LH34 shims are not split)**
- f) Fit the shims and retain them with the O-ring (31). **(No O-ring on LH32 and LH34 models)**
- g) Refit rotors and tighten retaining bolts (59) to correct torque. Recheck end clearance and re-adjust if necessary.

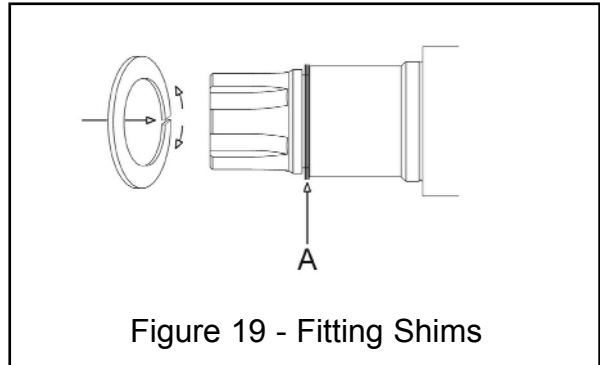

Figure 19 - Fitting Shims

If any side-to-side movement of the rotors can be detected or if the radial clearance is incorrect, check the condition of the bearings and their pre-load. (see section 7 Inspection and repair of gearbox.)

There is no adjustment for radial clearance - replace shafts and/or bearings if worn.

When re-assembling the pump always tighten screws to the correct torque specified on the Performance Data Sheet.

## 6.12 END COVER RELIEF VALVE

### Disassembly:

Before dismantling the relief valve assembly it is advisable to measure the distance from the end of the housing (133) to the end of the adjusting screw (155). This will enable the correct pressure setting to be re-set without having to go through the set up procedure.



New relief valves are not supplied factory set. This pressure setting should be done when the valve is fitted to the pump. See section 2.12

a) Remove the relief valve end cover assembly from the pump. Before doing so make a note of the position of the 'Direction of Flow' arrow.

b) Remove the adjusting screw (135).

c) Hook the spring (132) out from the top of the housing (133). Alternatively turn the valve upside down and tip the spring out.

d) Remove the 2 screws (136) and remove the housing (133).

e) The valve seat (128) and diaphragm (129) will come off of the end cover (125) together with the housing. To disassemble these tap the end of the guide pin (134) with a soft tool eg a screwdriver handle. The valve seat, diaphragm and piston/guide pin assembly should now separate from the housing.

f) Remove the O-ring (126) from the groove in the valve seat.

### Inspection:

a) Inspect the condition of the diaphragm. Look for splits, cracks or other signs of wear and fatigue. Replace as necessary.

b) Inspect the conical end of the piston (131) around the screw thread and around the outside edge of the cone to ensure there are no sharp edges or burrs.

### Re-assembly:

a) Lay the end cover (125) on its face.

b) Fit the O-ring (126) into the groove in the face of the valve seat (128). Use a suitable grease to 'stick' the O-ring in the groove.

c) Turn the valve seat upside down and place the seat onto the end cover with the O-ring towards the end cover ie the conical face uppermost. Position the 2 screw holes in the valve seat over the corresponding threaded holes in the end cover.

 Ensure that the X marked on the side of the seat is aligned with the X on the end cover.

d) Place the diaphragm onto the seat.

 Pumps fitted with Viton or PTFE pump head elastomers use a PTFE faced fluoroelastomer diaphragm. Ensure that the PTFE side is face down i.e. PTFE face is in contact with the valve seat.

e) Hold the housing (133) upside down and slide the piston/guide pin assembly into the housing, guide pin first. Place a finger into the thread end of the housing and hold the guide pin by pushing on its side. Turn the housing over so that the widest end is lowermost.

f) Place the housing / piston / guidepin assembly over the diaphragm / valve seat / end cover assembly such that the 2 holes align with the holes in the diaphragm.

g) Push the 2 screws (136) through the holes in the housing so that they locate into the threaded holes in the end cover.

h) Loosely tighten the screws.

i) Fit the spring and adjusting screw and tighten the screw until it contacts the spring.

j) Tighten the 2 retaining screws (136) to the correct torque.

k) The valve is now assembled and can be re-fitted to the pump.

 Ensure that the 'Direction of Flow' arrow is in the previously noted position.

l) If the valve was previously set and the adjusting screw to housing dimension had been noted (see note at start of Disassembly), re-set the adjusting screw to this dimension, this does not apply if a new spring has been fitted. Otherwise set the valve as in Section 2.12.

### **6.13 THERMAL JACKET - END COVER**

Ensure that the liquid feed to the jacket is switched off before attempting to service it.

- a) Dismantle the jacket (144) from the cover (143) by removing the screw(s) (147) from the centre of the jacket
- b) Remove the inner O-ring(s) (146) from the groove(s) around the screws and the outer O-ring(s) (145) from the groove around the outside edge of the jacket.
- c) Replace the O-rings and re-fit the jacket.
- d) Tighten the screws to the correct torque.

### **6.14 THERMAL JACKET - PUMP HEAD**

Ensure that the liquid feed to the jackets is switched off before attempting to service them.

- a) Dismantle the two jackets (139) from the end cover (138) by removing the screws (141).
- b) Remove the O-rings (140) from their grooves.
- c) Replace the O-rings and re-fit the jackets.
- d) Tighten the screws to the correct torque.

### **6.15 THERMAL JACKET - ROTOR CASE**

Ensure that the liquid feed to the jackets is switched off before attempting to service it.

- a) Dismantle the jackets from the rotor case (51) by removing the nuts (153) from the port retaining studs (152).
- b) Remove the joint rings (53 & 149) from the grooves in the ports and the jackets.
- c) Remove the screws from the jackets where fitted, and separate the 2 halves of the jackets
- d) Peel off the gaskets and clean the two mating faces of the jackets.
- e) Fit new gaskets (148) and re-assemble the 2 halves. Tighten the screws to the correct torque.
- f) Fit new port joints (53 & 149) and re-assemble the jackets to the rotor case.
- g) Tighten the nuts to the correct torque.

### **6.16 BEARING HOUSING**

Power input to the pump is via the drive shaft (24). The gearbox has two contra-rotating shafts (24 & 25), supported by taper roller bearings (4 & 5). The shafts are synchronized by a pair precision cut gears (6) that distribute power between the drive shaft (24) and driven (lay) shafts (25).

Hy~Line and Ultima pump gearboxes have been designed for easy inspection and maintenance. Care must be taken, as correct gearbox assembly is essential for effective pump operation and long-life. If in doubt consult your supplier or the manufacturer. (See figure 20).

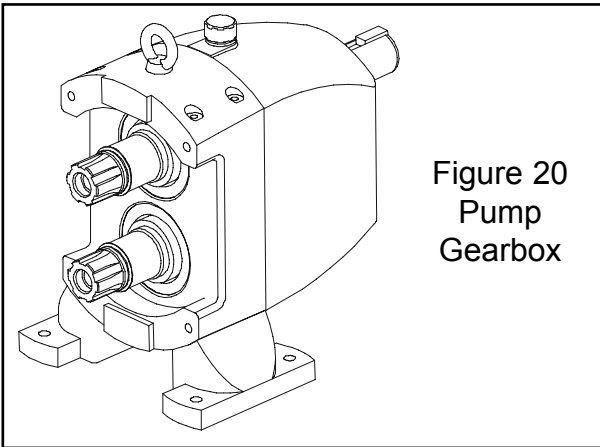

Figure 20  
Pump  
Gearbox

### Inspection:

Bearing housing (1) and gearbox internals can be inspected by removal of the gear cover (11). Before removing the gear cover (11) for inspection it is advisable to purchase, a new gearbox gasket (9) and two gearcover screw seals (4 screws on LH72, 74, 76) (19). Then proceed as follows:

- a) Disconnect pump from drive and remove shaft coupling.
- b) Drain lubricating oil from pump gearbox via drain plug (14).
- c) Remove two gear cover securing screws (18) and plastic sealing washers (19). (4 screws on 7 Size)
- d) Remove drive shaft key (29) and gearcover (11), taking care not to damage the drive shaft oil seal on the drive shaft key-way.
- e) Preliminary inspection can now be carried out without further dismantling. e.g. condition of timing gears or movement in the bearings.
- f) If all is found to be satisfactory, refit in reverse order using new gasket (9) & seals (19).

### Repair:

To repair the bearing housing assembly you will need the parts contained within the appropriate Repair Kit (k), in addition to any new gears (6) or bearings (4 & 5) required, which should be purchased before commencing.

### 6.17 GEARBOX SHAFTS, GEARS & BEARINGS

If the shafts are to be removed for any reason, label all components including bearing outer races, shims etc. and keep in their correct positions.

With the pump disconnected from its drive, remove rotorcase (see section 6.10), drain oil via plug (14) and remove gear cover (11), bend down the tab washers (7) which lock the gearnuts (8).

Before loosening the gearnuts (8) lock the rotors on the shaft using the plastic block supplied for this purpose. Loosen the gearnuts (8) using a C-spanner.

Remove gearnuts (8), tab washers (7), timing gears (6) and drive shaft keys (28), from the shafts.

#### For LH32 and LH34 models:

Remove gearnuts (8), tab washers (7), timing gears (6) and drive shaft keys (28), from the shaft.

Using a C-spanner loosen and remove the bearing nuts and tab washers from the shafts.

Using a light press or soft hammer, drive out the shafts (24 & 25) towards the front (rotorcase end) of the bearing housing (1) (See figure 21). This will push out the front oil seals (23).

The inner race of the rear bearing (4) will slide off the shaft. Be careful that it does not fall off. Alternatively, prise out the front lip seals (23) first with a sharp tool. Take care not to damage the bearing housing or journals of the shaft during this operation.

**!** Ultima **only:** The aluminium and stainless steel components of the Ultima bearing carrier are machined as an assembly and should never be dismantled.

The outer races of the bearings (4 & 5) can be pulled out of the housing (1) using your fingers.

To remove the inner race of the front bearing a press will be required.

Re-assemble in the reverse order, checking and re-adjusting the bearing pre-loads. (See section 6.18).

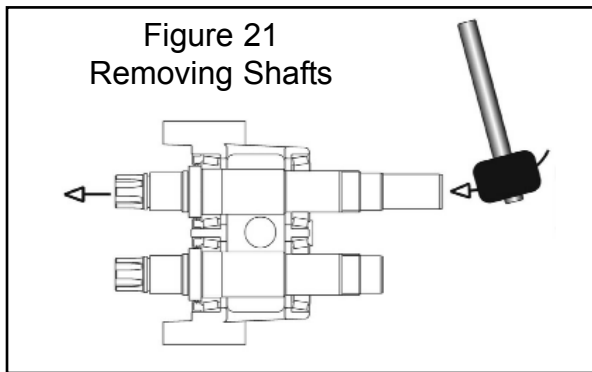

## 6.18 BEARING SET-UP AND PRE-LOAD

Each shaft is supported on 2 taper-roller bearings (front: 5) (rear: 4) which are pre-loaded to prevent any end-float (sideways movement) of the shafts (24 & 25).

If any movement is detected in either shaft (side to side or axially) new bearings must be fitted (see section 6.17) and correctly pre-loaded.

Assembly of the shafts is as follows:

Safety: Bearings inner races require heating to 110°C (230°F). **Protective gloves are essential.**

- a) **USE GLOVES:** Heat only front inner races of bearings (5) and assemble onto the shafts (24 & 25) making sure they are pressed tight up against the shoulders and are the correct way round. (See figure 22)
- b) Slide both front (5) and rear (4) outer races into the bearing housing. (See figure 23) **Note:** At this stage do NOT put additional oil on bearings.

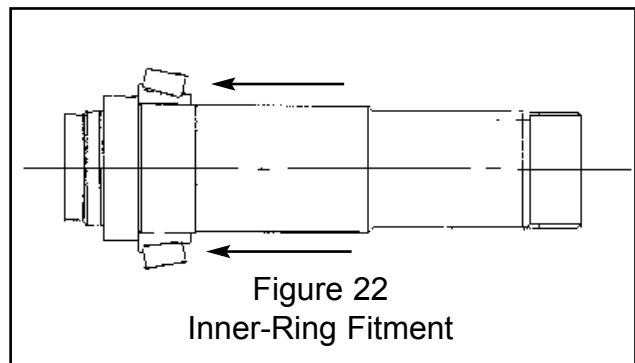

- c) Place driven shaft (25) into the bearing housing (1) from the front and slide the inner race of front bearing (4) onto the shaft until front and rear inner bearing races are in light contact with their outer races. Fit the gear drive key (28), gear (6), tab washer (7) and gear nut (8). Tighten the gear nut (8) by hand to hold the assembly in place, taking-up any end float. It may help to warm the inner race of the rear bearing to ease fitment onto the shaft.

**For LH32 and LH34 models:**

Do not fit gear drive key, gear, tab washer or gear nut. Instead fit tab washer (7a) and bearing nut (8a). Tighten the bearing nut by hand to hold the assembly in place, taking up any end float. It may help to warm the inner ring of the rear bearing to ease fitment onto the shaft.

- d) Rotate the shaft a minimum of 4 times and tighten the gear nut (8) again by hand. **(Bearing nut (8a) for LH32 and LH34 models)**
- e) Rotate the shaft a further 4 times, tighten the gear nut again by hand and then tighten the nut a further quarter turn, using the C-Spanner. **(Bearing nut 8a for LH32 and LH34 models)**
- f) Rotate the shaft 4 more times and torque the gear nut (8) to the figure shown on the performance data sheet. Repeat two-three times until no further tightening of the gear nut is perceived. **(Bearing nut (8a) for LH32 and LH34 models)**

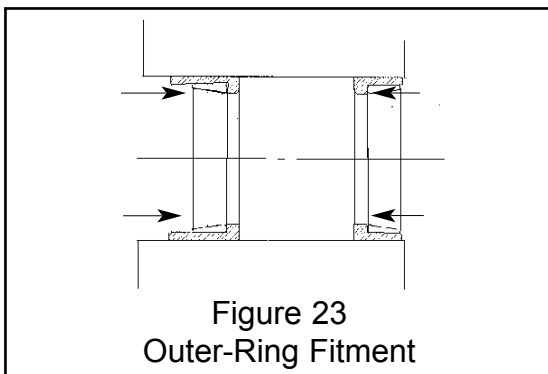

Figure 23  
Outer-Ring Fitment

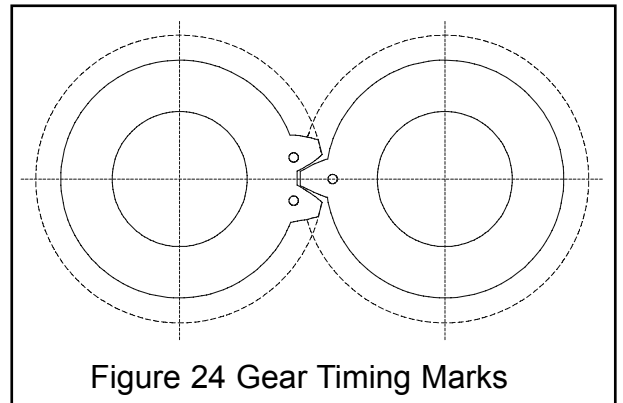

Figure 24 Gear Timing Marks

- g) Repeat c) to f) for drive shaft. Note: when fitting the second gear, align gear timing marks. (See figure 24).

**DO NOT fit gear (6) on LH32 and LH34 models.**

- h) Check that there is no perceptible movement of either shaft in any direction and **FINALLY BEND OVER TAB WASHERS** to lock the gear nuts.

**For LH32 and LH34 models:**

Before carrying out instruction i) fit the gear drive keys (28), gears (6), tab washers (7) and gear nuts (8). Ensure that the timing marks (see fig 24) are aligned. Tighten the gear nuts to the torque shown on the Performance Data Sheet. Finally, bend over the tab washers to lock the gear nut in place.

- i) Front oil seals (23) should be pressed in, until they are flush with the front face of the bearing housing (1). Take care not to curl or damage the lip or displace the gaiter spring on the shaft. Ensure they are square to the shaft (not tilted).

- j) Assemble gear cover (11) to bearing housing (1), using new gasket (9), new rear oil seals (20) and gearcover screw seals (19). Be careful not to damage the lip seal on the drive shaft keyway.
- k) Ensure vent plug (12) is at highest point, the sight glass (13) on the side of the cover and the oil drain outlet is at the lowest point and sealed with a suitable thread sealant.
- l) Re-fit seal housings if removed, rotorcase, seals, rotors and end cover as described in section 6. Remember to check rotor clearances (see section 6.11).
- m) Fill gearbox with the correct grade and quantity of oil. (see section 3) This should be to the centre of the sight glass (13).

Some oil may be retained in the sight glass and will give a false impression of the oil level. Be sure that the sight glass is full of oil to its centre.



### 7.00 MODEL NUMBER BUILD CODE

# LH 440 - 1890EY

Product Name	Size	Rotor Width		Port Size	Ports	Seals	Rotors	End Cover	Elastomers	Miscellaneous
		4	5							
Hy~Line LH	4	4	Short	Standard	No ports	0 Double, SIC/SIC, C/SIC	1 HI Efficiency	8 Plain	0 Nitrile trim	B Horizontal ports/Bottom shaft
	5	5	Medium	(H) In (L) out	Tri-clamp	1 Single SIC / SIC	2 High Press.	9 Jacket (endcover)	1 EPDM trim	E 316L Pumphead * (see note below)
	6	6		(H) In (H) out	BSP	2 Single C/SIC	3	Jacket (pumphead)	4 PTFE trim	P Stainless steel bearing & gear housing
				Hopper In	IDF	3 Double, C/SIC, C/SIC	4	Relief Valve (P-Jacket)	8 Viton Trim	V Vertical ports
				Enlarged	RJT	4 Flushed C/SIC	5	Relief Valve (P-Jacket)	9	E Electropolish
				Reduced	3A	5 Single O-Ring	6	Relief Valve (P-Jacket)		Z To 0.5 Micron polish & Electropolish
					DIN 11851	6 Flushed SIC/SIC	7			& Certification
					SMS	7 Single C/SS	8			
					NPT	9 Flushed C/SS	9			
						Double O-Ring				
						Multiple PTFE Lip Seal				

\* Ultima pump head is welded ports and gasket end cover joint  
 Note: Miscellaneous options L & S not available together. Use Ultima

# LU 520 - 1390BVZ&

Product Name	Size	Rotor Width		Port Size	Ports	Seals	Rotors	End Cover	Elastomers	Miscellaneous
		4	5							
Ultima LU	4	4	Short	Standard	Tri-clamp	1 Double, SIC/SIC, C/SIC	1 HI Efficiency	8 Plain	0 EPDM trim	B Horizontal ports/Bottom shaft
	5	5	Medium	Enlarged		2 Single SIC / SIC	2 High Press.	9 Jacket (endcover)	4 PTFE trim	E Horizontal ports/Top shaft
	6	6		Reduced		3 Single C/SIC	3	Barrier	5 Viton Trim	V Electropolish
						4 Double, C/SIC, C/SIC	4	Barrier(5) & Jacket(4)	7	Z To 0.5 Micron polish & Electropolish
						5 Flushed C/SIC	5	Jacket (pumphead)	8	& Certification
						6 Flushed SIC/SIC	7			

Note: Elastomer and Miscellaneous option suffix letters to be listed in alphabetical order.  
 (See example above)

## 8.01 PARTS LIST

### HOW TO IDENTIFY AND ORDER SPARE PARTS

1. From the pump nameplate identify the pump MODEL NUMBER and SERIAL NUMBER.
2. Use the MODEL BUILD CODE on page 36 to identify the pump specification.
3. Refer to the exploded view of the pump (pages 40 & 41) and the sectional views of the options (pages 42 & 43) in order to ascertain the parts required.
4. Use the parts list on pages 37-39 to cross check the item with the description.
5. Order spare part by **KEY** number and **DESCRIPTION** also quoting the **MODEL NUMBER** and **SERIAL NUMBER**.

Key	Description	Used with pump code	Qty Req.	Where used	
				Hy-Line	Ultima
1	Bearing carrier housing		1	✓	✓
2	Eye Bolt		1	✓	✓
3	Washer, eye bolt		1	✓	✓
4	Bearing, rear		2	✓	✓
5	Bearing, front		2	✓	✓
6	Timing Gear Set (2 gears per set)		1	✓	✓
7	Tab Washer, gear nut		2	✓	✓
8	Gear Nut		2	✓	✓
9	Gasket, Gear cover	All Pumps	1	✓	✓
10	Roll Pin, bearing carrier housing		2	✓	✓
11	Gear Cover		1	✓	✓
12	Plug, Oil filler/breather		1	✓	✓
13	Oil Level Window		1	✓	✓
14	Drain plug		1	✓	✓
15	Label, Hy-Line	All Hy-Line	1	✓	
16	Label, Rotary Lobe Pump	All Pumps	1	✓	✓
17	Label, Ultima	All Ultima	1	✓	✓
18	Hex Hd Screw Gear Cover		2	✓	✓
19	Washer (ny/on), gear cover, Nylite		2	✓	✓
20	Lip seal, Rear Gear Cover		2	✓	✓
21	Screws, foot mounting	All Pumps	4	✓	✓
22	Foot		2	✓	✓
23	Lip Seal Front, Bearing carrier housing		2	✓	✓
24	Shaft, driving		1	✓	✓
25	Shaft, driven		1	✓	✓
26	Tie Rod, Drive Shaft		1	✓	✓
27	Tie Rod, Driven Shaft	All Ultima	1		✓
28	Key, timing gear drive		2	✓	✓
29	Key, drive shaft		1	✓	✓
30	Shim Kit, rotor clearance <b>Kit A</b>	All Pumps	1	✓	✓
31	O ring, Shim retention -		2	✓	✓
32	Nut		2	✓	✓
33	Washer, locating		2	✓	✓
	<b>Gearbox Service Kit K</b>		1	✓	✓
51	Rotor Case .		1	✓	✓
52	Screw, Rotorcase		4	✓	✓
53	Port Joint ring	All Hy-Line	2	✓	✓
54	Port Kit <b>Kit B</b>	except with Suffix L	1	✓	✓
55	Screw, for retaining Bolt-on		8	✓	✓
56	<b>Rotor Kit - Hy-Line Kit C</b>	All Hy-Line	1	✓	
57	<b>Rotor Kit - Ultima Kit C</b>	All Ultima	1		✓
58	O Ring, Rotor retainer	All Hy-line	2	✓	
59	Rotor Retaining Screw		2	✓	
60	Shaft guard	Not Shown	2	✓	✓
61	Shaft guard stud	Not Shown	2	✓	✓
62	Shaft guard nut	Not Shown	2	✓	✓
	<b>Rotor Case Side Jacket Kit V</b>		2	✓	✓
63	Gasket- outer		2	✓	✓
64	Port seal ring (see item 53)		4	✓	✓
65	Cap screw- Long	Only if fitted	12/16/20	✓	
66	Cap screw -Short		4	✓	✓
67	Stud		4	✓	✓
68	Nut		4	✓	✓
	<b>Pump Head Trim Kit Kit J</b>	Seal code 1, 2, 3, 4, 5, 7, 8 or 9 + No Suffix or Suffix E or V	1	✓	

## 8.01 PARTS LIST

Key	Description	Used with pump code	Qty Req.	Where used
				Hy-Line   Ultima
<b>O-RING SEAL - DOUBLE</b>				
	<b>Double O-Ring Seal Kit</b>			
	Kit R			
102	Seal Sleeve		1	✓
			2	✓
103	Seal Housing		2	✓
104	O-Ring- Housing	Seal code D	4	✓
105	O-Ring- Flush housing		2	✓
106	Housing-Flush		2	✓
107	Bolt, Flush Housing		4	✓
<b>RELIEF VALVE</b>				
	<b>Relief Valve Kit</b>			
	Kit H			
124	End Cover		1	✓
125	O-ring - Relief valve		1	✓
126	O-ring - Relief valve		1	✓
128	Seat- Relief Valve Standard		1	✓
129	Diaphragm- Relief Valve		1	✓
131	Plunger	End Cover code 1 or 9	1	✓
132	Spring- Relief valve		1	✓
133	Housing		1	✓
134	Valve Guide		1	✓
135	Adjusting Screw		1	✓
136	Bolt- Relief Valve/End Cover		2	✓
<b>THERMAL JACKETS - PUMP HEAD</b>				
	<b>Pump Head Jacket Kit</b>			
	Kit U			
138	End cover	End Cover code 7 or 8	1	✓
139	Jacket		2	✓
140	O-ring		2	✓
141	Screws		4	✓
<b>THERMAL JACKET - END COVER</b>				
	<b>End Cover Jacket Kit</b>			
	Kit T			
143	End Cover		1	✓
144	Jacket		1	✓
145	O-ring -outer	End Cover code 4	1	✓
146	O-ring inner		1	✓
147	Screws	(Quantity varies by pump size 4 size = 1off, 5 and 6 size = 2 off)	1 or 2	✓

Key	Description	Used with pump code	Qty Req.	Where used
				Hy-Line   Ultima
<b>SINGLE MECH SEAL</b>				
	<b>Primary Seal Face Kit</b>			
	Kit D			
80	Primary Seal Face Kit	Seal code 1, 2	2	✓
81	Drive plate, mechanical seal primary	3, 4, 5, 7, 8 or 9	2	✓
82	Wave Spring, mechanical seal		2	✓
83	Single Seal Trim Kit (Primary seal)	Seal code 1, 2, 3, 4, 5, 7, 8 or 9 + No Suffix or Suffix E or V	2	✓
83a	Washer under seal rotary face (fitted to rotor)	Seal 1, 2, 3, 4, 5, 7, 8 or 9 +	2	✓
83b	PTFE sleeve (fitted to rotor)	Suffix P	2	✓
83c	PTFE encapsulated O-Ring (fitted to rotor case)		2	✓
84	Clamp plate, Seal housing		4	✓
85	Screw, Seal Housing	Seal code 1, 2, 3, 4, 5, 7, 8 or 9	4	✓
86	Seal Housing Kit		2	✓
<b>FLUSH FOR SINGLE MECH SEAL</b>				
	<b>Seal Housing Kit</b>			
	Kit M			
89	Seal Housing Kit	Seal code 5, 7 or 9	2	✓
89a	Washer		2	✓
90	Lip Seal, seal housing (Nitrile)		2	✓
91	O Ring, seal housing (Nitrile)		2	✓
<b>DOUBLE MECH SEAL</b>				
	<b>Secondary Seal Face Kit</b>			
	Kit F			
92	Secondary Seal Face Kit		2	✓
92a	Rubber Washer		2	✓
92b	Drive Ring	Seal code 1 or 4	2	✓
93	Secondary		2	✓
94	Drive plate, mechanical seal secondary		2	✓
95	Seal Housing Kit		2	✓
<b>O-RING SEAL - SINGLE</b>				
	<b>Single O-Ring Seal Kit</b>			
	Kit P			
96	Seal Sleeve	Seal code 6	1	✓
97	Seal Housing		2	✓
98	Retaining Nut		2	✓
99	O-Ring- Rotor		2	✓
100	O-Ring- Primary seal (Qty=2 on single, 4 on Double)	Seal code 6 or D	2/4	✓
101	O-Ring- Seal housing		2	✓

TOOLS				
Key	Description	Used with pump code	Qty Req.	Where used
				Hy-Line   Ultima
180	Tool, rotor locking pad (plastic)	All	1	✓
181	Socket Tool, rotor retainer	All Hy-Line	1	✓
182	Tool, seal seat removal	All	2	✓

## 8.01 PARTS LIST - CONTENTS OF KITS

Kit No.	Key No.	Description	Qty per Kit	Where Used		
				Hy-Line	Ultima	
N	<b>Housing Kit - Double Flushed Mechanical Seal</b>					
	82	Wave spring	1	✓	✓	
	81	Drive ring primary seal	2			
	94	Drive ring secondary seal	2			
	95	Pin, for drive plate retention	3			
P	95	Housing, for double seal	1			
	91	O ring, to seal housing to rotorcase	1			
R	<b>Single O-Ring Seal Kit</b>					
	96	Seal Sleeve	2	✓		
	97	Seal Housing	2			
	98	Retaining Nut	2			
	99	O-Ring- Rotor	2			
	100	O-Ring- Primary seal	2			
	101	O-Ring- Seal housing	2			
S	<b>Double O-Ring Seal Kit</b>					
	51	Rotor Case - Double O-ring Seal - Bolt on ports	1	✓		
	99	O-Ring- Rotor	2			
	100	O-Ring- Primary seal	4			
	102	Seal Sleeve	2			
	103	Seal Housing	2			
	104	O-Ring- Housing	4			
	105	O-Ring- Flush housing	4			
	106	Housing-Flush	2			
	107	Bolt, Flush Housing	2			
	107	Bolt, Flush Housing	4			
	T	<b>Multi Lip Seal Kit</b>				
		51	Rotor case - Multi Lip Seal - Bolt on ports	1	✓	
106		O-Ring- lip seal	8			
107		Lip seal	8			
108		O-Ring- seal sleeve	2			
109		Seal sleeve	2			
110		Grease Container	2			
111		Screw	4			
112		Nut	4			
113		Hose Assembly Short	1			
114		Hose Assembly Long	1			
115		Mounting Bracket	1			
116		Screw	4			
117		Nut	4			
118		Washer	4			
119	Foot	1				
119A	Screw	2				
U	<b>End Cover Jacket Kit</b>					
	63-68	Complete assembly to replace plain end cover	1	✓	✓	
V	<b>Thermal Jackets - Pump Head-Kit</b>					
	138-141	Complete assembly to replace plain end cover	1	✓	✓	
V	<b>Thermal Jacket - Rotor Case Side Jackets</b>					
	143-147	Complete assembly to fit	1	✓	✓	

Kit No.	Key No.	Description	Qty per Kit	Where Used	
				Hy-Line	Ultima
A	<b>Shim Kit, Rotor Clearance</b>				
	30	Shims for two shafts	14	✓	✓
B	<b>Bolt-on Port Kits</b>				
	31	O ring, for retaining shims	2		
C	<b>Joint Ring - Nitrile</b>				
	53	Joint Ring - Nitrile	2	✓	✓
D	<b>Bolt on port</b>				
	54	Bolt on port	2	✓	✓
E	<b>Rotor Kits</b>				
	56 & 57	Rotor	2	✓	✓
F	<b>Primary Seal Face Kit</b>				
	80	Rotary primary seal seat	1	✓	✓
G	<b>Stationary primary seal seat</b>				
	80	Stationary primary seal seat	1	✓	✓
H	<b>Single Seal Trim Kit (in various materials)</b>				
	83	L-cup, for rotary primary seal seat	1	✓	✓
I	<b>O ring or Quad ring</b>				
	83	O ring or Quad ring	1	✓	✓
J	<b>Secondary Seal Face Kit (for double seal)</b>				
	92	Rotary secondary seal seat	1	✓	✓
K	<b>Stationary secondary seal seat</b>				
	92	Stationary secondary seal seat	1	✓	✓
L	<b>Gasket, rubber</b>				
	92a	Gasket, rubber	1	✓	✓
M	<b>Drive ring, for rotary seal seat</b>				
	92b	Drive ring, for rotary seal seat	1	✓	✓
N	<b>Pin, for drive ring</b>				
	92b	Pin, for drive ring	1	✓	✓
O	<b>Secondary Seal Trim Kit</b>				
	93	O ring, for rotary secondary seal seat	1	✓	✓
P	<b>O ring, for stationary secondary seal seat</b>				
	93	O ring, for stationary secondary seal seat	1	✓	✓
Q	<b>O ring, for seal housing to rotorcase</b>				
	91	O ring, for seal housing to rotorcase	1	✓	✓
R	<b>Pressure Relief Valve</b>				
	125-136	Complete assembly to replace plain end cover	1	✓	✓
S	<b>Pump Head Trim Kit</b>				
	83	L-cup, for rotary primary seal seat	2	✓	✓
T	<b>O ring or Quad ring</b>				
	83	O ring or Quad ring	2	✓	✓
U	<b>O ring, for rotor retaining screw</b>				
	58	O ring, for rotor retaining screw	2	✓	✓
V	<b>O ring or compression joint, end cover</b>				
	120	O ring or compression joint, end cover	1	✓	✓
W	<b>Port joint rings</b>				
	53	Port joint rings	2	✓	✓
X	<b>Gear Box Service Kit</b>				
	23	Front oil seal, for bearing housing	2	✓	✓
Y	<b>Rear oil seals, for gear cover</b>				
	20	Rear oil seals, for gear cover	2	✓	✓
Z	<b>Gasket, gear cover</b>				
	9	Gasket, gear cover	1	✓	✓
AA	<b>Washer, for sealing gear cover screws</b>				
	19	Washer, for sealing gear cover screws	2	✓	✓
AB	<b>Housing Kit-Single Mechanical Seal (no flush)</b>				
	82	Wave spring	1	✓	✓
AC	<b>Drive ring</b>				
	81	Drive ring	1	✓	✓
AD	<b>Pin, for drive plate retention</b>				
	86	Pin, for drive plate retention	3	✓	✓
AE	<b>Housing, for single seal</b>				
	86	Housing, for single seal	1	✓	✓
AF	<b>Housing Kit-Single Flushed Mechanical Seal</b>				
	82	Wave spring	1	✓	✓
AG	<b>Drive ring</b>				
	81	Drive ring	1	✓	✓
AH	<b>Pin, for drive plate retention</b>				
	89	Pin, for drive plate retention	3	✓	✓
AI	<b>Housing, for flushed sea</b>				
	89	Housing, for flushed sea	1	✓	✓
AJ	<b>O ring, to seal housing to rotorcase</b>				
	91	O ring, to seal housing to rotorcase	1	✓	✓

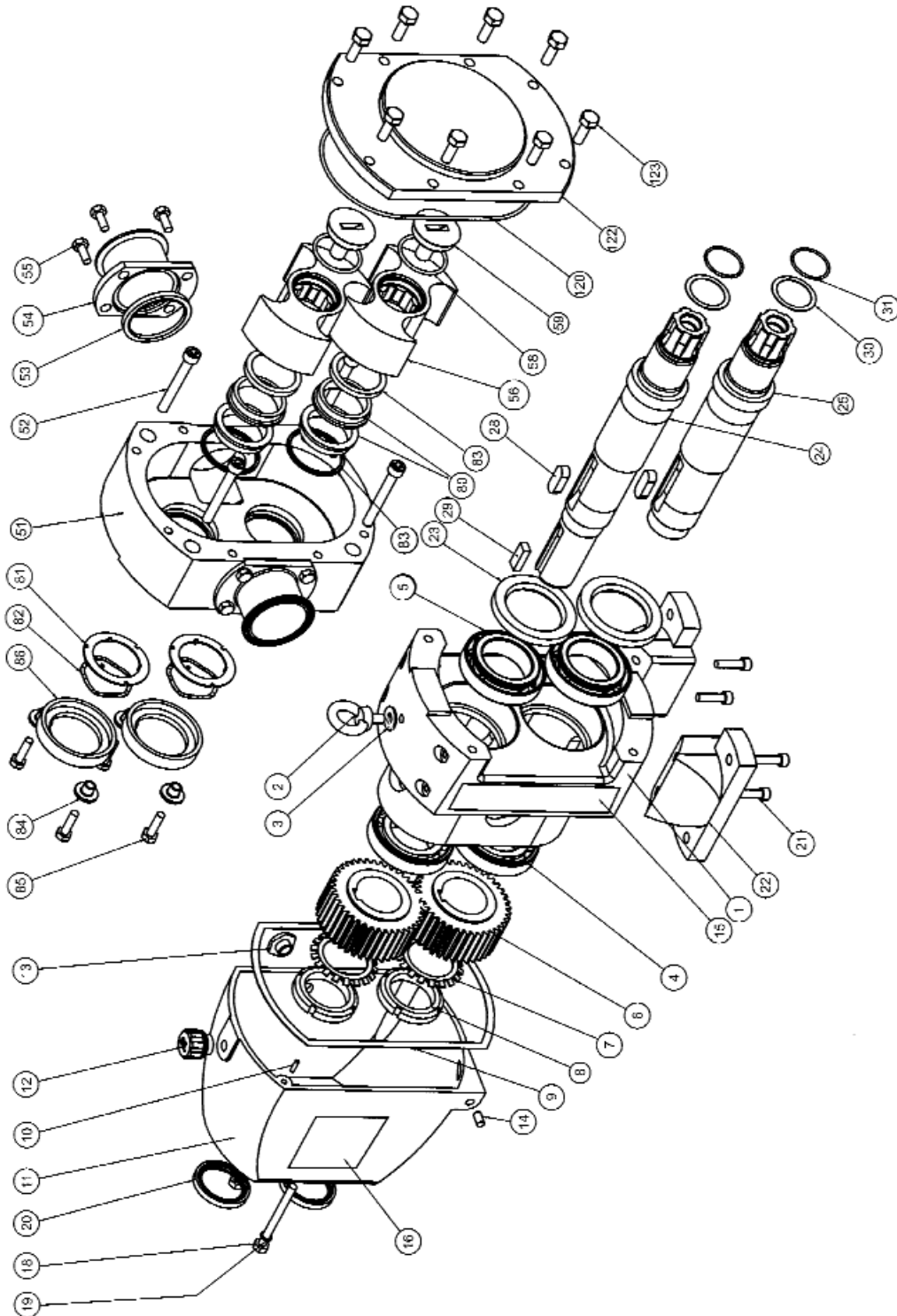
**8.02 Hy~Line EXPLODED DIAGRAM**

## 8.03 Ultima EXPLODED DIAGRAM

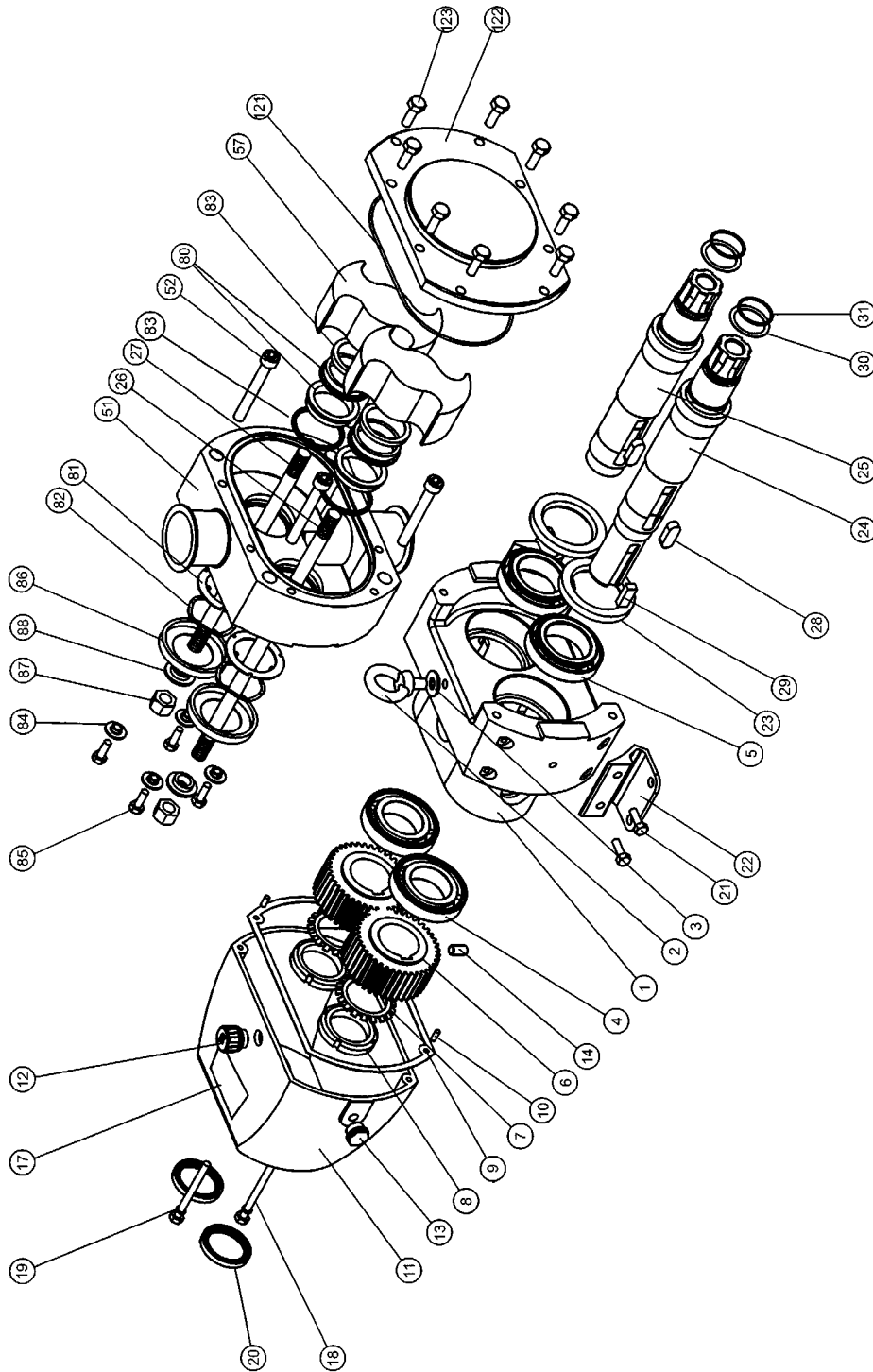

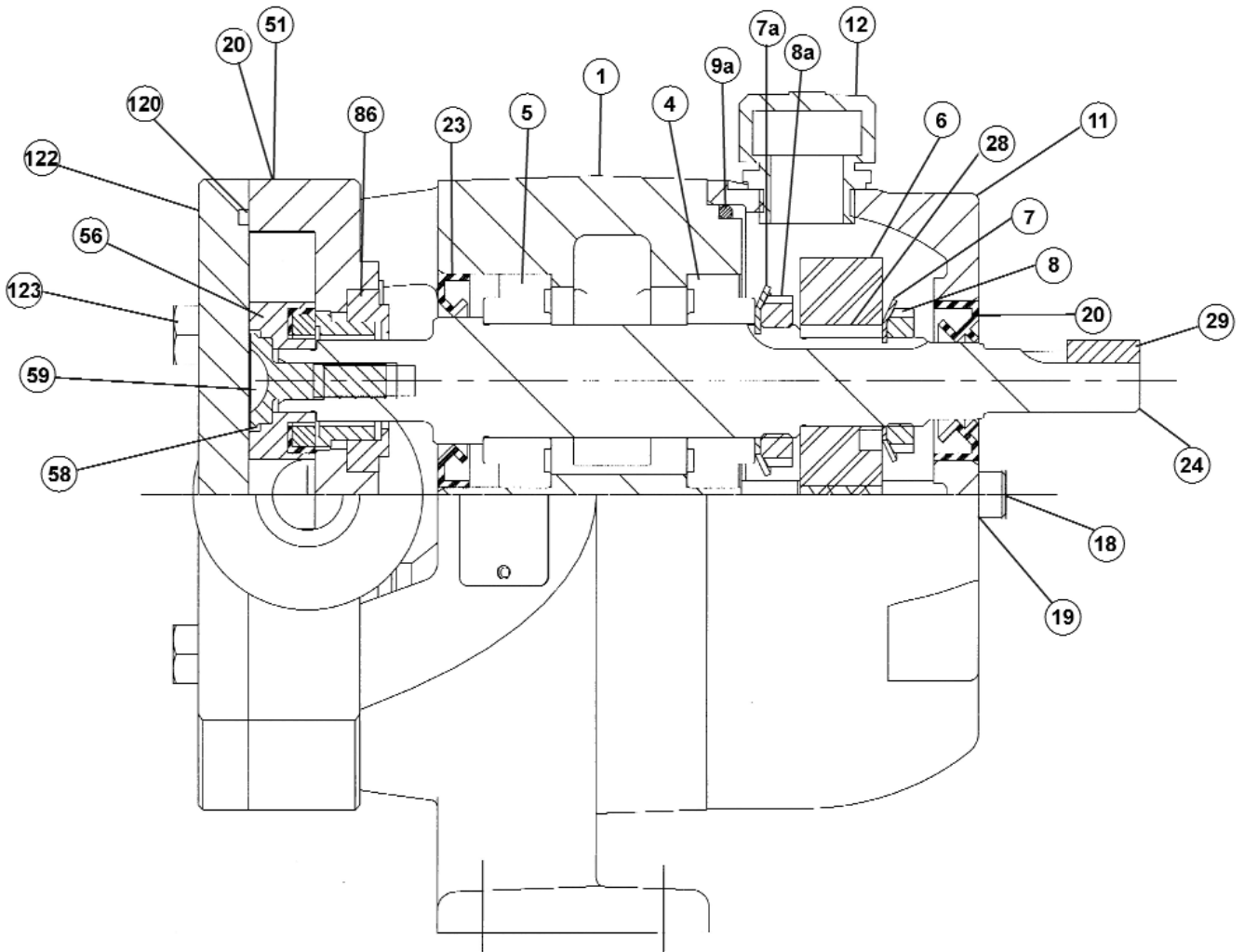
**8.04 Hy~Line 3 Size SECTIONAL VIEW**

## 8.05 OPTIONS & EXTRAS - SECTIONAL VIEWS

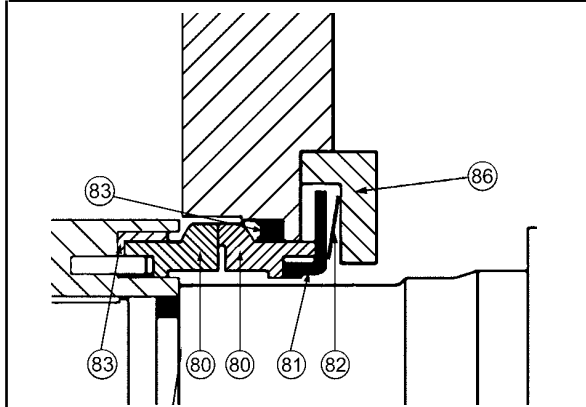

**Single Mechanical Seal**

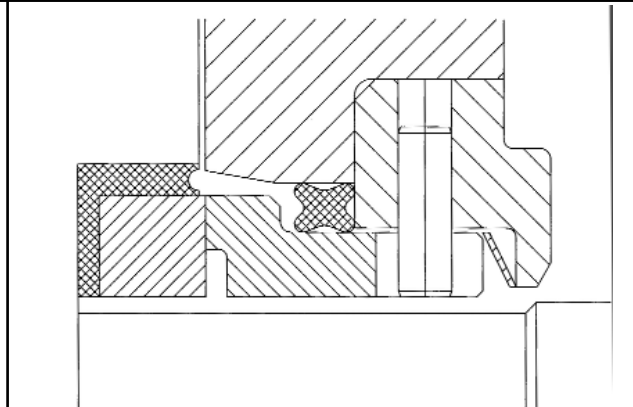

**Hy-Line 3 Size Single Mechanical Seal**

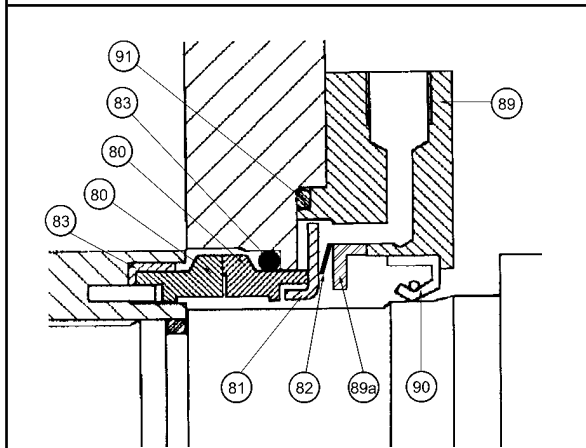

**Flushed Mechanical Seal**

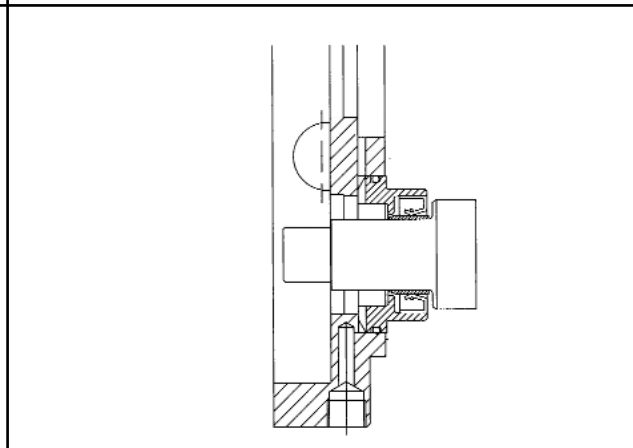

**Hy-Line 3 Size Flushed Mechanical Seal**

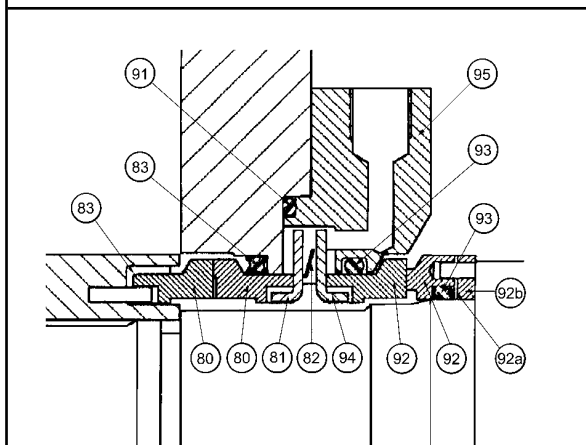

**Double Mechanical Seal**

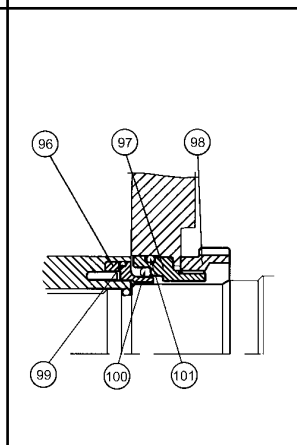

**Single O-ring Seal**

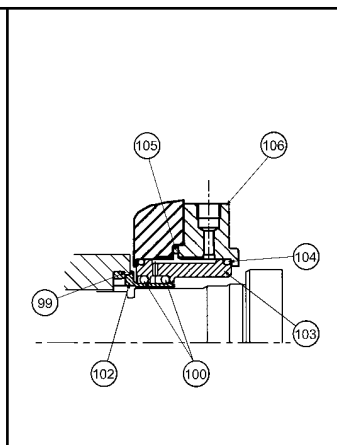

**Double O-ring Seal**



**8.05 OPTIONS & EXTRAS - SECTIONAL VIEWS**

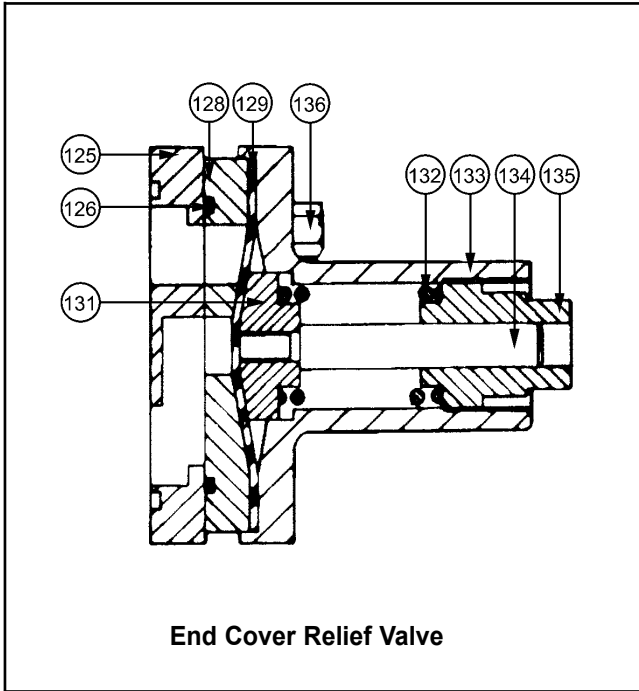

**End Cover Relief Valve**

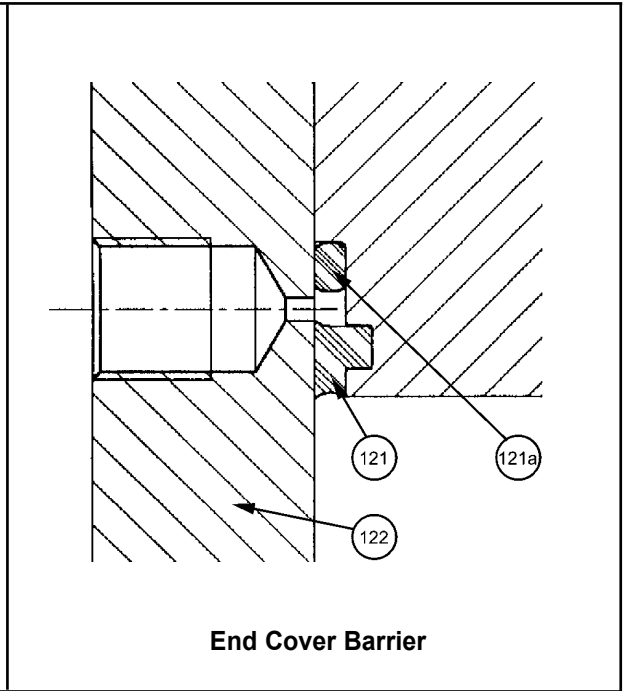

**End Cover Barrier**

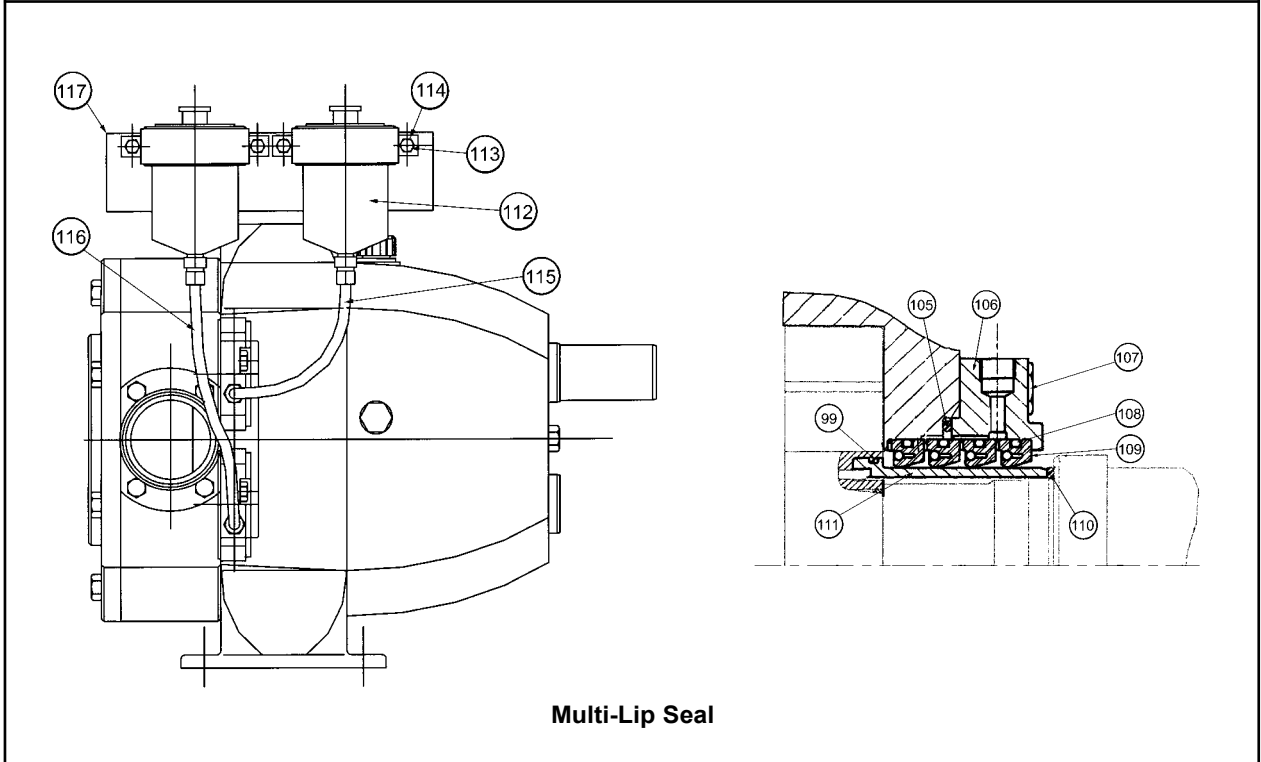

**Multi-Lip Seal**

## 8.05 OPTIONS & EXTRAS - SECTIONAL VIEWS

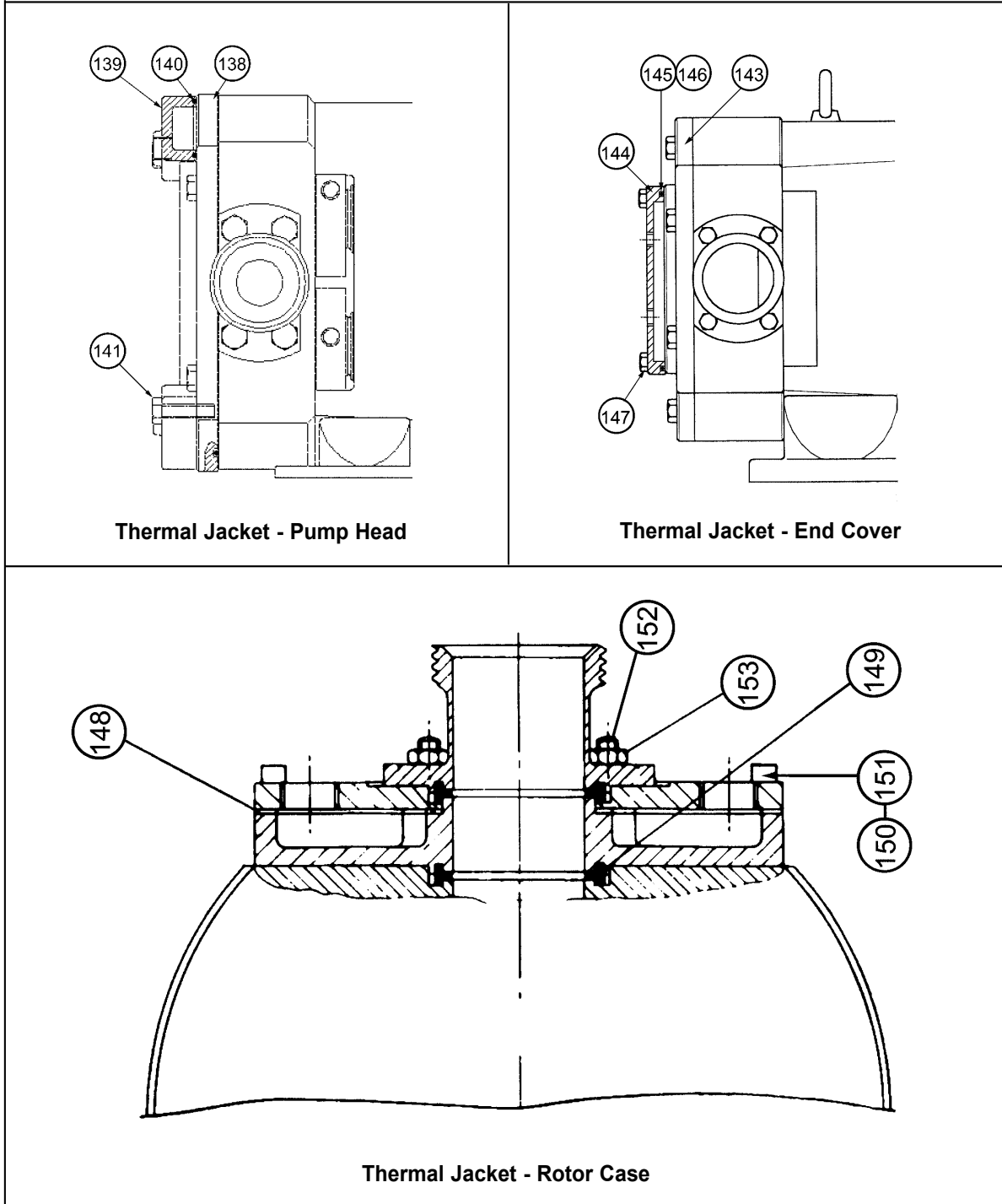



**ITT Industries**

*Jabsco*  
Bingley Road  
Hoddesdon  
Hertfordshire  
EN11 0BU  
England  
Telephone (01992) 450 145  
International +44 1992 450 145  
Fax (01992) 467 132



## Declaration of Incorporation

**Subject Machinery Directive 98/37/EC**

ITT Jabsco declares that the products listed below conform to all relevant parts of the above directive, and should not be put in to service until the relevant machinery into which they are to be incorporated have been declared in conformity with provisions of the Machinery Directive.

ITT Jabsco declare que les produits ci-listés se conforment à la norme CE 98/37/EC et ne doivent pas être utilisés dans des machines qui ne sont pas conformes aux normes en question ci-dessus.

ITT Jabsco bestätigt, daß alle unten aufgelisteten Produkte den zutreffenden Teilen der Vorschrift entsprechen. Die produkte sollten aber erst dann in Betrieb genommen werden, nachdem die Maschine, in die diese Teile eingebaut werden, für Richtlinien konform erklärt worden ist.

**Product Type** Hy~Line Rotary Lobe Pumps  
with model prefix references:

LH32	LH62
LH34	LH64
LH42	LH72
LH44	LH74
LH52	LH76
LH54	

**Signed** Engineering Manager



**Date** 20/01/03

Quality Manager



**Date** 1/21/03



ITT Industries

**Jabsco**  
 Bingley Road  
 Hoddesdon  
 Hertfordshire  
 EN11 0BU  
 England  
 Telephone (01992) 450 145  
 International +44 1992 450 145  
 Fax (01992) 467 132

**Declaration of Incorporation**

**Subject Machinery Directive 98/37/EC**

ITT Jabsco declares that the products listed below conform to all relevant parts of the above directive, and should not be put in to service until the relevant machinery into which they are to be incorporated have been declared in conformity with provisions of the Machinery Directive.

ITT Jabsco declare que les produits ci-listés se conforment à la norme CE 98/37/EC et ne doivent pas être utilisés dans des machines qui ne sont pas conformes aux normes en question ci-dessus.

ITT Jabsco bestätigt, daß alle untenaufgelisteten Produkte den zutreffenden Teilen der Vorschrift entsprechen. Die produkte sollten aber erst dann in Betrieb genommen werden, nachdem die Maschine, in die diese Teile eingebaut werden, für Richtlinien konform erklärt worden ist.

**Product Type** Ultima Rotary Lobe Pumps  
 with model prefix references:  
 LU42  
 LU44  
 LU52  
 LU54  
 LU62  
 LU64

**Signed** Engineering Manager  **Date** 20/01/03

Quality Manager  **Date** 1/21/03

A Division of ITT Industries Ltd. Registered England No. 814151. Registered Office: Jays Close, Viabes Estate, Basingstoke, Hants RG22 4BW

**Jabsco****ITT Industries****USA**

**Jabsco**  
 20 Icon  
 Foothill Ranch  
 CA 92610-3000

Tel : +1 949 609 5106  
 Fax : +1 949 859 1254

**UK**

**Jabsco**  
 Bingley Road  
 Hoddesdon  
 Hertfordshire, EN11 0BU

Tel : +44 (0) 1992 450 145  
 Fax : +44 (0) 1992 467 132

**GERMANY**

**Jabsco GmbH**  
 Oststrasse 28  
 22844 Norderstedt

Tel : +49 (0) 40 53 53 73 0  
 Fax : +49 (0) 40 53 53 73 11