



User Benefits

The Jabsco Hy~Line and Ultima ranges are two variants of a common theme. Both demonstrate high standards of design and manufacture and share many features. They are both aimed at users in Food and Dairy production, Healthcare products, Chemical and Industrial applications, Pharmaceuticals & Bioprocessing yet they are two very different pump ranges, each aimed at a particular type of application. Jabsco gives the lobe pump user a choice:



Fig 1

Hy~Line offers high reliability, low noise, low product damage, easy servicing and efficient handling of a wide variety of liquids. Hy~Line offers levels of hygiene and chemical resistance to suit many transfer, filtration and processing applications and can be cleaned in place (CIP) to a level adequate for many users. Some variants approved to EHEDG CIP protocols



Fig 2

Ultima, as the name suggests, combines all of the above with even higher standards of in-place cleanability (CIP) & sterilization (SIP), process containment and purity of liquid for applications where compromise is not an option. Ultima is used in truly sterile applications and everywhere that only the highest system cleaning capability is good enough. Approved to EHEDG CIP, SIP & bacterial tightness protocols

This commonality between the two pumps has benefits too. Users who require both hygienic and ultra-hygienic lobe pumps in their process can now source both pump types from one supplier. Hy~Line and Ultima share not only installation dimensions but also performance characteristics and many common spare parts as well.

Note : EHEDG = European Hygienic Equipment Design Group



Hy-Line and Ultima Lobe Pumps

2/00

5.12

Shared Features and Benefits

- High efficiency pumping thin liquids, reduced shear damage to suspended organisms
- High-viscosity liquids handled with minimal shear damage to their structure
- Low noise for a safe and comfortable working environment
- Front-loaded shaft seals give long life, effective CIP and quick strip & repair
- Easy maintenance features include in place removable rotor case. (No need to remove gear cover, bearing shaft, gear arrangements or drain the oil before replacing the rotor case).
- Non-contacting rotors minimize risk of particles shed into fluid stream
- All-metal construction with 316 grade stainless steel fluid contact parts
- US 3A conforming hygienic construction
- Temperature-stable design compatible with high fluid temperatures and steam
- Fully-drainable pump head prevents liquid retention
- Smooth, attractive external shape does not collect pools of wash-down water
- Adaptable mounting for vertical or horizontal pipework
- Scimitar rotors do not require critical shaft synchronization
- Large-diameter rigid shafts maintain accurate rotor position and resist high pressures

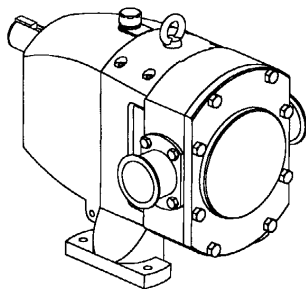

Fig 3

Hy-Line Features and Benefits

- Flush, sealed rotor-fixing screws reduce crevices and are unlikely to loosen on start-up
- Epoxy coated bearing housing has good corrosion resistance and smooth, clean surface
- Bolt-on ports allow quick adaptation to any pipe system and reduce repair costs

Ultima Features and Benefits

All the areas found in traditional pump designs which make them difficult to clean and sterilize have been totally eliminated, for example:-

- External rotor fixing totally eliminates nuts, bolts, screws or splines in fluid contact for highest levels of CIP & SIP
- Minimum number of joints for maximum bacteria tightness
- No O-rings in fluid contact - gasket-type joints further improve CIP capability
- Stainless-steel bearing housing gives total corrosion resistance and avoids paint chipping
- 316L low-carbon grade stainless-steel contact parts minimizes carbon 'pull-out'
- Elastomers conforming and certified to US FDA requirements

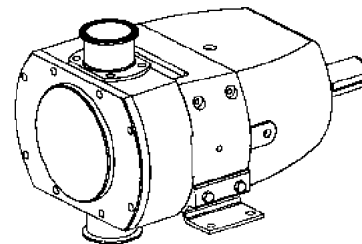

Fig 4

Jabsco



ITT Industries

USA

Jabsco
20 Icon
Foothill Ranch
CA 92610-3000

Tel : +1 949 609 5106
Fax : +1 949 859 1254

UK

Jabsco
Bingley Road
Hoddesdon
Hertfordshire, EN11 0BU

Tel : +44 (0) 1992 450 145
Fax : +44 (0) 1992 467 132

GERMANY

Jabsco GmbH
Oststrasse 28
22844 Norderstedt

Tel : +49 (0) 40 53 53 73 0
Fax : +49 (0) 40 53 53 73 11

Basic Principles of Design and Operation

Jabsco Hy~Line and Ultima positive displacement rotary Lobe Pumps are designed to pump delicate, viscous and particle-laden fluids as well as thin liquids which require an all stainless steel pump. The design of Jabsco Lobe Pumps is influenced by some fundamental engineering principles and it is useful to understand these first to ensure their most effective selection and operation.

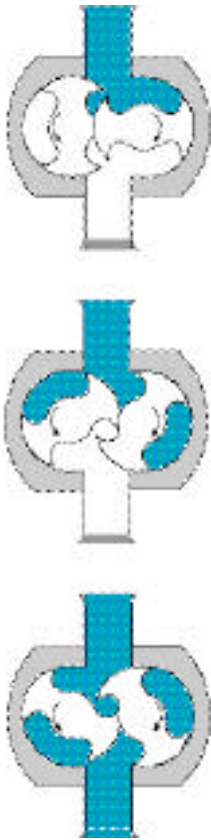

Fig 1

All Hy~Line and Ultima Lobe Pumps use the same principle of operation. Two rotors turn in opposite directions; fluid enters the pump from the inlet port and fills the space between the rotors. This fluid is carried around the outside of the rotors and is forced out of the discharge port as the rotor lobes mesh together - see Fig 1.

The displaced flow rate of the pump is therefore directly proportional to the diameter of the rotors and the speed at which the pump rotates.

The bearings are permanently lubricated and are sealed from the pump head ensuring that:

- No lubricant contaminates the pumped fluid
- No bearing material is worn away
- No pumped fluid (which may be corrosive or abrasive) can enter the bearings
- No pumped fluid is trapped behind bearings from where it cannot be cleaned out

Rotor Lengths

Being a positive displacement pump, flow is related not only to the rotor diameter but also the rotor length. A rotor length increased by 50% will displace 50% more flow. The longer rotor also has a larger surface area on which the fluid pressure acts trying to force the rotor to one side (see Fig 3). Therefore longer rotors put more load on the pump shafts and bearings at any particular pressure, so the maximum working pressure of a pump using a long rotor is lower than that of a short rotor, limited by the clearances provided and Ultimately by the shaft strength.

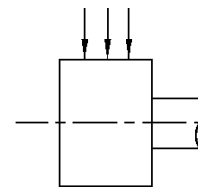

Fig 3

Overhung Rotors

In Jabsco Lobe Pumps, each rotor is supported on its own shaft and there are no bearings inside the pump chamber, so all forces from the fluid pressure are transmitted through the shafts to external bearings. The rotors are therefore overhung, as the shafts are cantilevered (see Fig 2) and are designed to resist the fluid pressure without excessive bending.

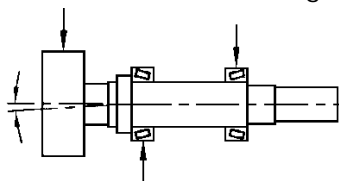

Fig 2

Rotor Clearances

When the pump is running within its operating limits, the rotors never touch each other and never touch the case in which they rotate. Fig 4 overleaf, shows the areas where small clearances are provided: between the two rotors (a), at the tips of the rotors (b) and on the front and rear faces (c). These clearances are typically only 0.05 to 0.25mm (0.002 to 0.010 inches). This absence of contact ensures that no material contaminates the pumped fluid and also makes Jabsco lobe pumps ideal for abrasive fluids.

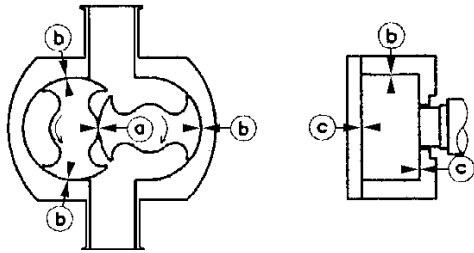

Fig 4

Separate "timing" gears exactly synchronize the rotation of the two shafts to ensure that the pump head components do not touch, unlike for example gear pumps where one gear drives the other and can wear, resulting in a loss of efficiency.

Volumetric Efficiency

The clearances within the pump head must be large enough to allow for shaft deflection under pressure and for thermal expansion without rotor contact but must also be kept as small as possible to maintain pump efficiency. Volumetric efficiency is lost when liquid "slips" from the discharge side back to the inlet side through the rotor clearances. The amount of slip is affected by the size of the clearances, the differential pressure generated by the pump and the fluid viscosity: Larger clearances result in higher slip; the fluid can more easily leak back through the larger area (Fig 5). Higher pressure results in higher slip; the pressure forces more liquid back through the clearances (Fig 6). Higher fluid viscosity results in lower slip; high-viscosity liquids flow less easily through the pump head clearances than thin liquids (Fig 7).

Therefore, especially when pumping thinner liquids, rotor clearances are kept as small as possible to maintain efficiency. However, higher pressures force the rotors sideways within the rotor case, towards the inlet port, also slightly tilting the rotors. Therefore for higher pressures, more clearance is necessary to prevent rotor to rotor case contact, up to a maximum allowable for a particular shaft and rotor configuration. Lastly, high operating temperatures and, especially, sudden changes in temperature e.g. during CIP result in different rates of expansion of the pump head components. Therefore sufficient clearance must be provided to allow for this.

Fig 5

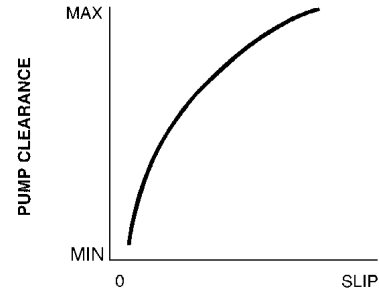

Fig 6

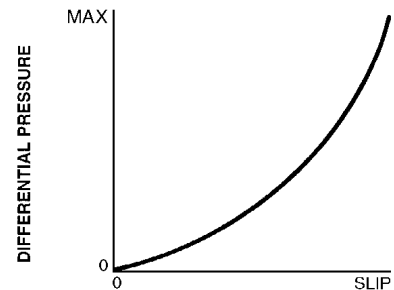
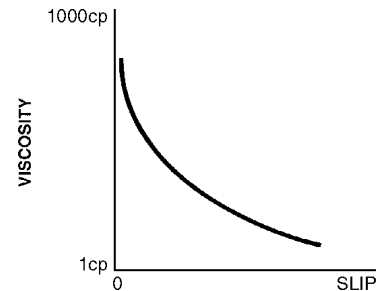

Fig 7



Pump Output

From the above, it can clearly be seen that the output flow rate from a Lobe Pump is a function of:

- Rotor diameter
- Rotor length
- Speed of rotation
- Lost flow due to slip back through internal clearances

The speed at which the pump runs is calculated to displace the required flow, plus extra displacement to compensate for any slip.

Jabsco



ITT Industries

USA

Jabsco
20 Icon
Foothill Ranch
CA 92610-3000

Tel : +1 949 609 5106
Fax : +1 949 859 1254

UK

Jabsco
Bingley Road
Hoddesdon
Hertfordshire, EN11 0BU

Tel : +44 (0) 1992 450 145
Fax : +44 (0) 1992 467 132

GERMANY

Jabsco GmbH
Oststrasse 28
22844 Norderstedt

Tel : +49 (0) 40 53 53 73 0
Fax : +49 (0) 40 53 53 73 11



Hy-Line Lobe Pumps

9/00

5.28

Bare Pump Dimensions in Millimeters

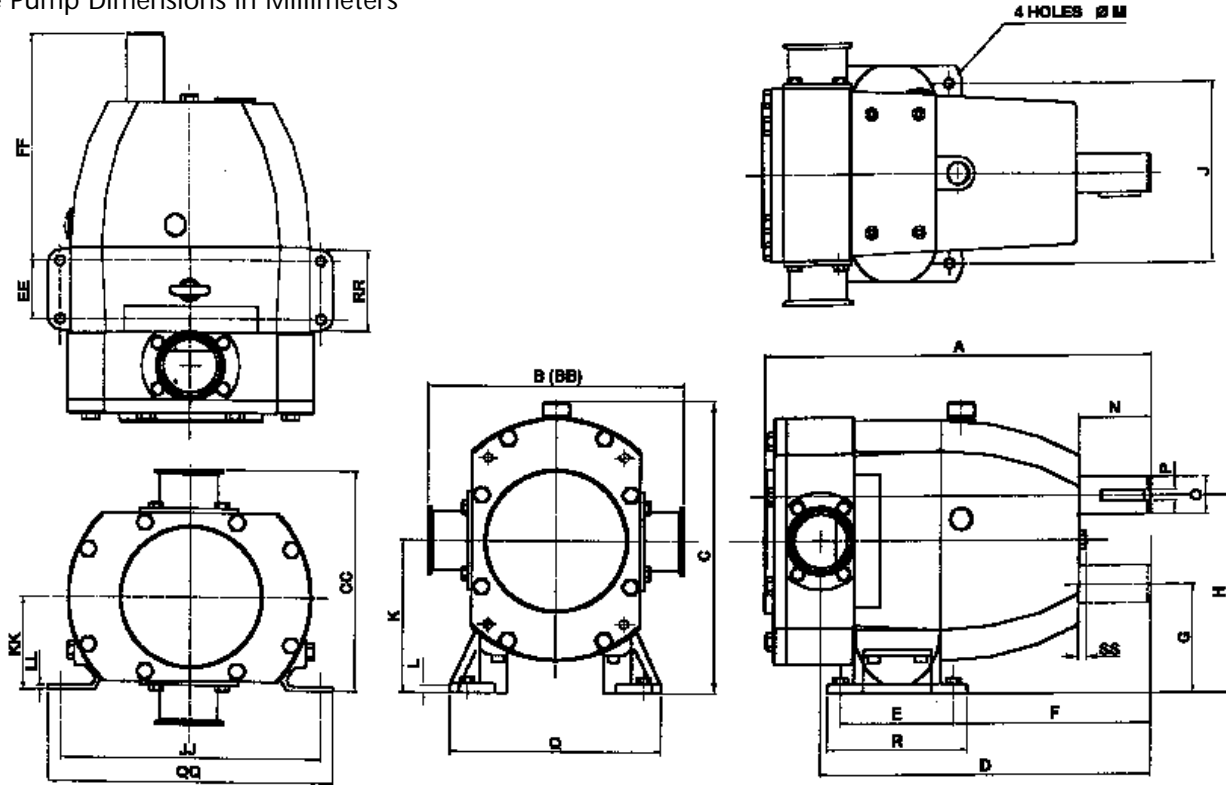

The dimensions shown here are for guidance purposes only, refer to Jabsco for certified drawings.

Pump	A	B	C	D	E	F	G	H	J	K	L	M	N	O	P	Q	R
42	274	223	196	231	72	142	67	132	150	99	6	9	40	24	8	180	92
44	290	223	196	241	72	142	67	132	150	99	6	9	40	24	8	180	92
52	368	249	244	319	84	209	80	160	180	120	6	9	83	38	10	214	104
54	396	259	244	338	84	209	80	160	180	120	6	9	83	38	10	214	104
62	435	288	311	372	122	225	125	225	200	175	10	11	83	42	12	240	157
64	464	302	311	381	122	225	125	225	200	175	10	11	83	42	12	240	157

Pump	BB	CC	EE	FF	JJ	KK	LL	QQ	RR	SS	Weight kg						
42	223	182	32	162	200	71	5	216	49	4.0							18
44	223	182	32	162	200	71	5	216	49	4.0							20
52	249	208	42	230	228	83	5	249	62	5.5							32
54	259	213	42	230	228	83	5	249	62	5.5							35
62	296	249	65	252	294	105	5	322	90	5.5							61
64	302	256	65	252	294	105	5	322	90	5.5							65

Note: Dimensions (B = Standard port size) & (BB = Enlarged port size)

 	USA Jabsco 20 Icon Foothill Ranch CA 92610-3000 Tel : +1 949 609 5106 Fax : +1 949 859 1254	UK Jabsco Bingley Road Hoddesdon Hertfordshire, EN11 0BU Tel : +44 (0) 1992 450 145 Fax : +44 (0) 1992 467 132	GERMANY Jabsco GmbH Oststrasse 28 22844 Norderstedt Tel : +49 (0) 40 53 53 73 0 Fax : +49 (0) 40 53 53 73 11
------	---	--	---



Ultima Lobe Pumps

9/00

5.32

Bare Pump Dimensions in Millimeters

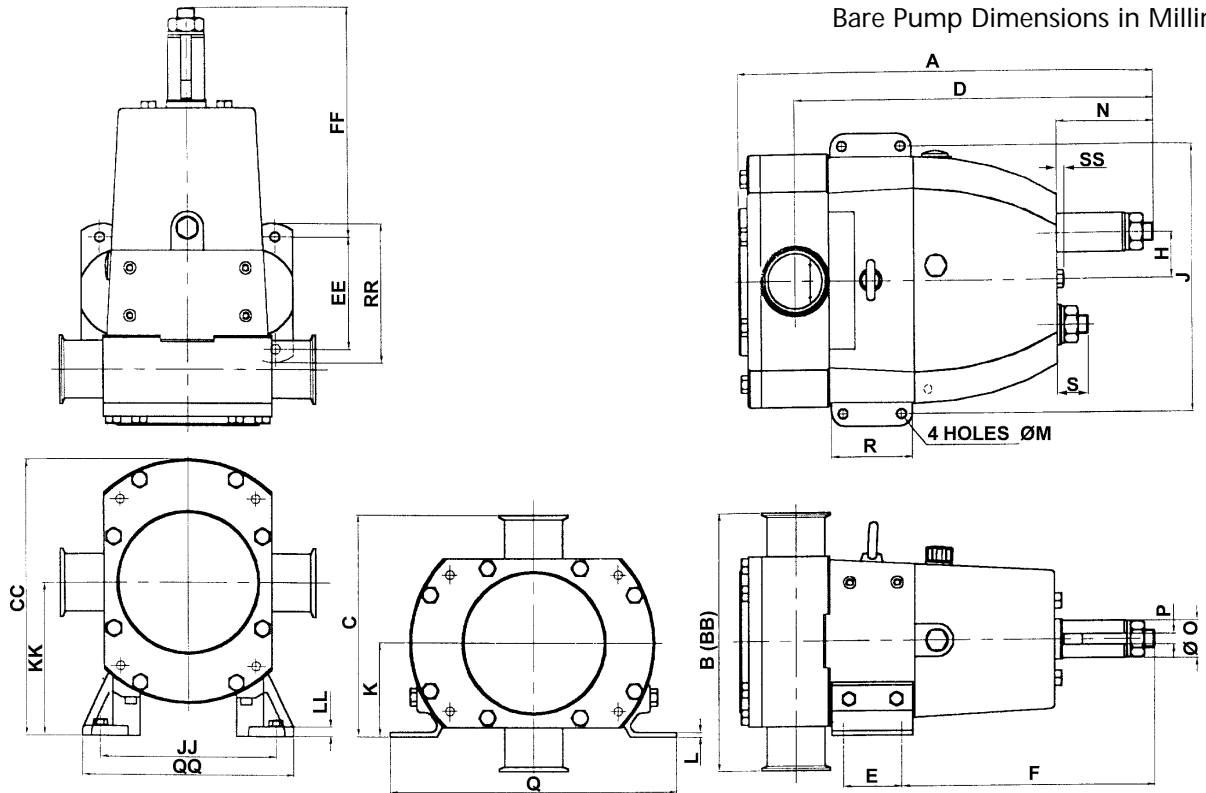

The dimensions shown here are for guidance purposes only, refer to Jabsco for certified drawings.

Pump	A	B	C	D	E	F	G	H	J	K	L	M	N	O	P	Q	R
42	285	223	182	242	32	173	71	32.5	200	71	5	9	51	24	8	216	49
44	301	223	182	252	32	173	71	32.5	200	71	5	9	51	24	8	216	49
52	386	249	208	337	42	247	83	40	228	83	5	9	100	38	10	249	62
54	414	259	213	356	42	247	83	40	228	83	5	9	100	38	10	249	62
62	463	328	249	400	65	282	105	50	294	105	5	11	107	42	12	322	90
64	492	328	253	408	65	282	105	50	294	105	5	11	107	42	12	322	90

Pump	S	BB	CC	EE	FF	JJ	KK	LL	QQ	RR	SS	Weight kg				
42	13	TBA	196	72	153	150	99	7	182	102	4.0	23				
44	13	TBA	196	72	153	150	99	7	182	102	4.0	25				
52	27	TBA	244	84	226	180	120	6	214	104	5.5	38				
54	27	TBA	244	84	226	180	120	6	214	104	5.5	41				
62	24	TBA	311	122	254	200	175	6	240	157	5.5	70				
64	24	TBA	311	122	254	200	175	6	240	157	5.5	75				

Note: Dimensions (B = Standard port size & Tri-Clamp enlarged port size) & (BB = Other enlarged port size)

 	USA Jabsco 20 Icon Foothill Ranch CA 92610-3000 Tel : +1 949 609 5106 Fax : +1 949 859 1254	UK Jabsco Bingley Road Hoddesdon Hertfordshire, EN11 0BU Tel : +44 (0) 1992 450 145 Fax : +44 (0) 1992 467 132	GERMANY Jabsco GmbH Oststrasse 28 22844 Norderstedt Tel : +49 (0) 40 53 53 73 0 Fax : +49 (0) 40 53 53 73 11
------	---	--	---

Warranty: All products of the company are sold and all services of the company are offered subject to the company's warranty and terms and conditions of sale, copies of which will be furnished upon request. The information provided herein is for guidance only, it does not constitute a guarantee of the performance or specification of any individual product or component.



Hy-Line Lobe Pumps

9/00

5.28

Bare Pump Dimensions in Inches

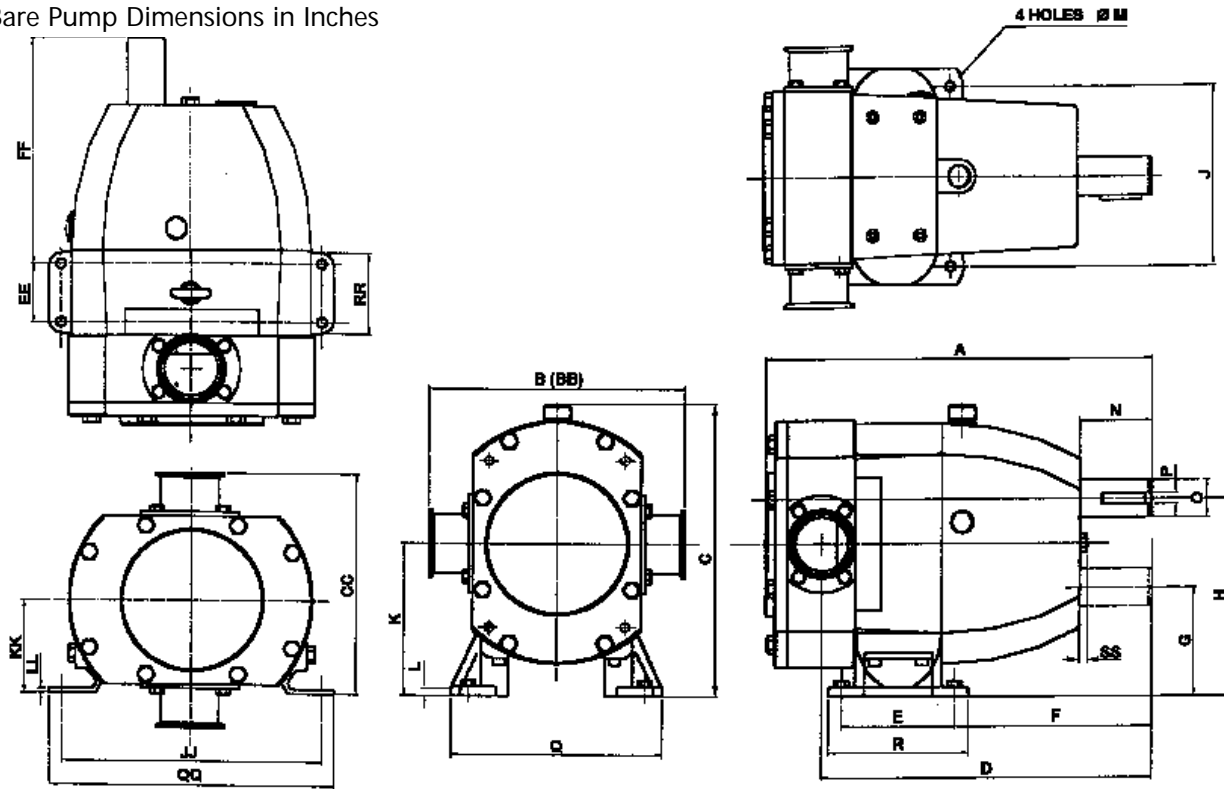

The dimensions shown here are for guidance purposes only, refer to Jabsco for certified drawings.

Pump	A	B	C	D	E	F	G	H	J	K	L	M	N	O	P	Q	R
42	10.8	8.78	7.7	9.1	2.83	5.6	2.64	5.20	5.90	3.90	0.24	0.35	1.57	0.945	0.315	7.1	3.6
44	11.4	8.78	7.7	9.5	2.83	5.6	2.64	5.20	5.90	3.90	0.24	0.35	1.57	0.945	0.315	7.1	3.6
52	14.5	9.80	9.6	12.6	3.30	8.2	3.15	6.30	7.09	4.72	0.24	0.35	3.27	1.496	0.394	8.4	4.1
54	15.6	10.20	9.6	13.3	3.30	8.2	3.15	6.30	7.09	4.72	0.24	0.35	3.27	1.496	0.394	8.4	4.1
62	17.1	11.34	12.2	14.6	4.80	8.9	4.92	8.86	7.87	6.89	0.40	0.43	3.27	1.653	0.472	9.5	6.2
64	18.3	11.89	12.2	15.0	4.80	8.9	4.92	8.86	7.87	6.89	0.40	0.43	3.27	1.653	0.472	9.5	6.2

Pump	BB	CC	EE	FF	JJ	KK	LL	QQ	RR	SS							Weight lbs
42	8.78	7.2	1.26	6.4	7.88	2.78	0.2	8.5	1.9	0.16							40
44	8.78	7.2	1.26	6.4	7.88	2.78	0.2	8.5	1.9	0.16							44
52	8.80	8.2	1.65	9.1	8.98	3.30	0.2	9.8	2.4	0.22							71
54	10.20	8.4	1.65	9.1	8.98	3.30	0.2	9.8	2.4	0.22							77
62	11.65	9.8	2.56	9.9	11.57	4.13	0.2	12.6	3.5	0.22							134
64	11.89	10.1	2.56	9.9	11.57	4.13	0.2	12.6	3.5	0.22							143

Note: Dimensions (B = Standard port size) & (BB = Enlarged port size)

 	USA Jabsco 20 Icon Foothill Ranch CA 92610-3000 Tel : +1 949 609 5106 Fax : +1 949 859 1254	UK Jabsco Bingley Road Hoddesdon Hertfordshire, EN11 0BU Tel : +44 (0) 1992 450 145 Fax : +44 (0) 1992 467 132	GERMANY Jabsco GmbH Oststrasse 28 22844 Norderstedt Tel : +49 (0) 40 53 53 73 0 Fax : +49 (0) 40 53 53 73 11
------	---	--	---

Warranty: All products of the company are sold and all services of the company are offered subject to the company's warranty and terms and conditions of sale, copies of which will be furnished upon request. The information provided herein is for guidance only, it does not constitute a guarantee of the performance or specification of any individual product or component.

©Copyright 2002ITT Industries - Jabsco



Ultima Lobe Pumps

9/00

5.32

Bare Pump Dimensions in Inches

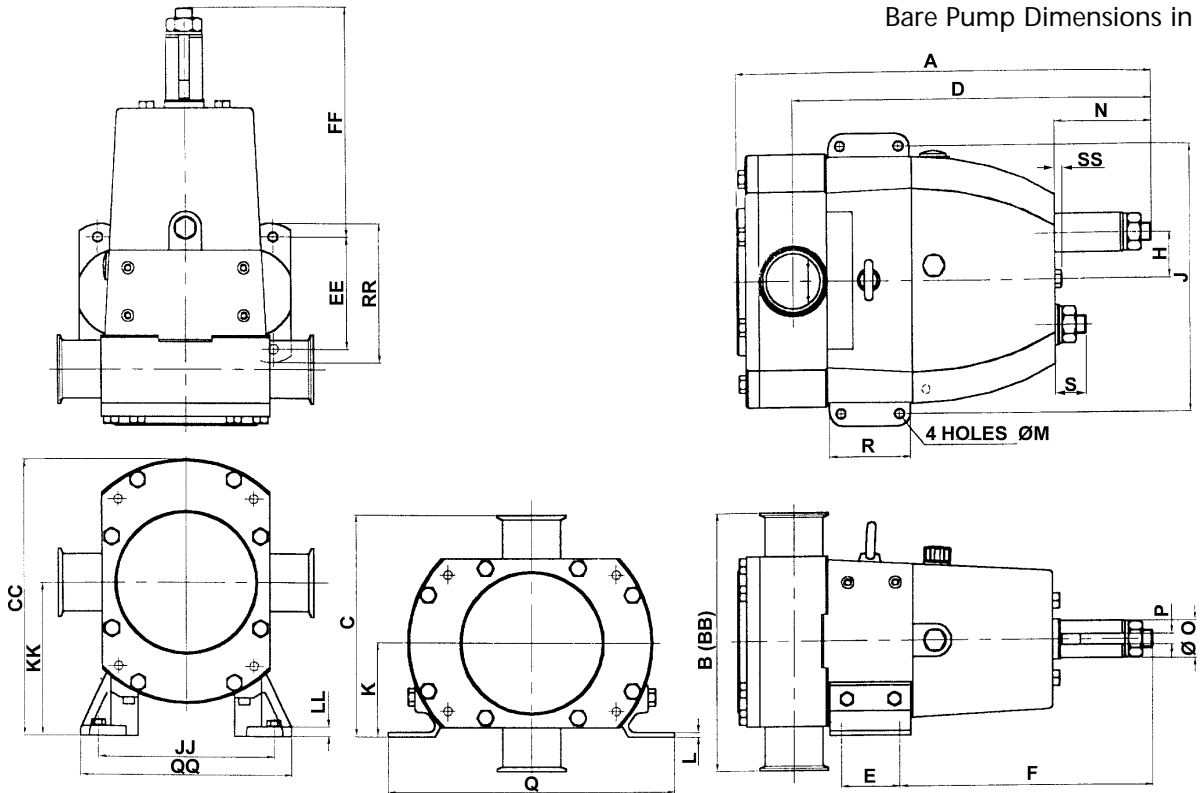

The dimensions shown here are for guidance purposes only, refer to Jabsco for certified drawings.

Pump	A	B	C	D	E	F	G	H	J	K	L	M	N	O	P	Q	R
42	11.2	8.8	7.2	9.5	1.26	6.8	2.80	1.28	7.87	2.80	0.2	0.35	2.01	0.945	0.315	8.5	1.9
44	11.9	8.8	7.2	9.9	1.26	6.8	2.80	1.28	7.87	2.80	0.2	0.35	2.01	0.945	0.315	8.5	1.9
52	15.2	9.8	8.2	13.3	1.65	9.7	3.27	1.57	8.98	3.30	0.2	0.35	3.94	1.496	0.394	9.8	2.4
54	16.3	10.2	8.4	14.0	1.65	9.7	3.27	1.57	8.98	3.30	0.2	0.35	3.94	1.496	0.394	9.8	2.4
62	18.2	12.9	9.8	15.7	2.56	11.1	4.13	1.97	11.57	4.13	0.2	0.43	4.21	1.654	0.472	12.7	3.5
64	19.4	12.9	10.0	16.1	2.56	11.1	4.13	1.97	11.57	4.13	0.2	0.43	4.21	1.654	0.472	12.7	3.5

Pump	S	BB	CC	EE	FF	JJ	KK	LL	QQ	RR	SS	Weight lbs					
42	0.5	TBA	7.7	2.83	6.0	5.9	3.90	0.28	7.2	4.0	0.16	51					
44	0.5	TBA	7.7	2.83	6.0	5.9	3.90	0.28	7.2	4.0	0.16	55					
52	1.1	TBA	9.6	3.31	8.9	7.1	4.72	0.24	8.4	4.1	0.22	83					
54	1.1	TBA	9.6	3.31	8.9	7.1	4.72	0.24	8.4	4.1	0.22	89					
62	0.9	TBA	12.2	4.80	10.0	7.9	6.89	0.24	9.4	6.2	0.22	153					
64	0.9	TBA	12.2	4.80	10.0	7.9	6.89	0.24	9.4	6.2	0.22	165					

Note: Dimensions (B = Standard port size & Tri-Clamp enlarged port size) & (BB = Other enlarged port size)

Jabsco



ITT Industries

USA

Jabsco
20 Icon
Foothill Ranch
CA 92610-3000

Tel : +1 949 609 5106
Fax : +1 949 859 1254

UK

Jabsco
Bingley Road
Hoddesdon
Hertfordshire, EN11 0BU

Tel : +44 (0) 1992 450 145
Fax : +44 (0) 1992 467 132

GERMANY

Jabsco GmbH
Oststrasse 28
22844 Norderstedt

Tel : +49 (0) 40 53 53 73 0
Fax : +49 (0) 40 53 53 73 11

Materials and Design

Hy~Line and Ultima pump rotor cases and end-covers are fully machined all over to precision tolerances and the rotor case is rigidly located on the bearing housing by machined lugs to maintain correct rotor clearances. The rotor bores have a straight-sided bore shape to allow low-viscosity liquids and cleaning solutions to self-drain when the pump is side-mounted (pipework axis vertical). This ensures that expensive product is not retained in the system, that cleaning and sterilization is improved and that there is minimal cross-contamination between product batches. - Fig 1

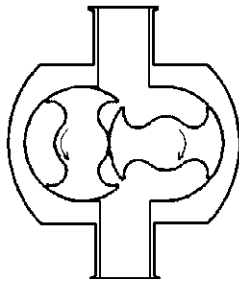

Fig 1

Materials

Hy~Line liquid-contact parts are normally manufactured from an austenitic stainless-steel generally referred to by the US designation 316 (European designation 1.4401). This gives high levels of hygiene and corrosion resistance adequate for most users at an economic price. Low carbon 316L is available as an option.

Ultima parts are made from low-carbon 316L (European designation 1.4404) as standard. This grade of stainless-steel has less than 0.03% carbon and there are two reasons for using this grade:

High corrosion resistance: When 316 grade stainless steel is welded, the heat can cause localized precipitation of carbides in the steel. These areas of high carbide concentration are susceptible to chemical attack. Low carbon grade steel used in Ultima pumps does not generate these localized weak areas. As the ports are bolted onto Hy~Line pumps, unlike many other manufacturers' pumps, 316L is not necessary on these pumps.

Low carbon pull-out: Low-carbon austenitic stainless steel (316L) is required to handle demineralized water of the type used for water of injection (WFI). Demineralized water is water that has had all trace minerals removed and therefore has many open chemical bonds which are trying to attach to free minerals such as carbon. High-carbon-content stainless-steels are susceptible to carbon "pull-out" i.e. carbon present at the surface of the metal of the pump will be pulled out and will cause re-mineralization of the water which is undesirable. A low carbon steel is not affected in this way.

Bearing Housing Assembly

Hy~Line and Ultima pumps are designed with smooth external contours which will freely drain of wash down solutions and which have minimal areas for dust and dirt collection. Hy~Line bearing housing are cast from LM31 grade aluminum alloy and treated with an electrostatically applied epoxy-polyester powder coating. This gives a hard, smooth and chemically-resistant surface. Ultima bearing housings are cast from stainless-steel grade 304 and machined all over to give a totally corrosion resistant surface for the most demanding environments. As this does not need to be painted, there is no risk of paint particles entering the process. Internally the bearings are mounted in an aluminum carrier; this ensures the bearing bores can be machined to precise diameters. - Fig 2

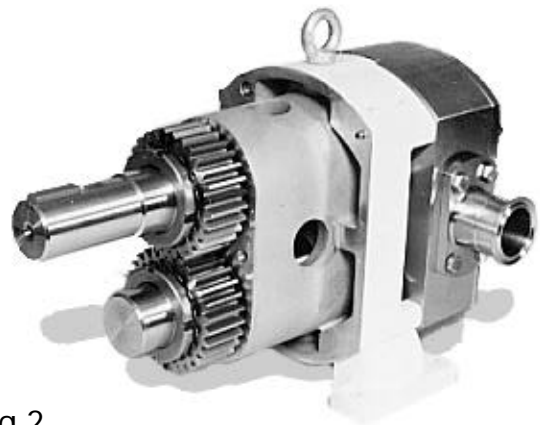

Fig 2



Hy~Line and Ultima Lobe Pumps

2/00

6.06

Hy~Line and Ultima pumps are fitted with large-diameter high strength shafts. There is no shimming adjustment required for gears and bearings and the wide timing gears are easily accessible so that semi-skilled labor can maintain the pump.

Hy~Line and Ultima pumps have bolt-on feet and can be adapted to three mounting options:



Fig 3

- Horizontal pipe orientation, high drive shaft position (standard supply for Hy~Line) - Fig 3



Fig 4

- Horizontal pipe orientation, low drive shaft position - Fig 4



Fig 5

- Vertical pipe orientation (standard supply for Ultima) - Fig 5

To change any pump from vertical to horizontal pipework or vice versa, a conversion kit containing the required feet and other components is available. To convert a pump from high shaft to low shaft, it is necessary only to reverse the feet and timing gear cover positions. No new parts are required.

Jabsco



ITT Industries

USA

Jabsco
20 Icon
Foothill Ranch
CA 92610-3000

Tel : +1 949 609 5106
Fax : +1 949 859 1254

UK

Jabsco
Bingley Road
Hoddesdon
Hertfordshire, EN11 0BU

Tel : +44 (0) 1992 450 145
Fax : +44 (0) 1992 467 132

GERMANY

Jabsco GmbH
Oststrasse 28
22844 Norderstedt

Tel : +49 (0) 40 53 53 73 0
Fax : +49 (0) 40 53 53 73 11

Scimitar Rotors

Hy~Line and Ultima pumps use scimitar type rotors, also known as "2-wing" or "By-wing" rotors - Fig 1. These are designed to achieve very high efficiencies on thin liquids and will also handle viscous liquids with minimal shear, plus the ability to pass small soft solids with minimal damage. Even when used in the straight-sided self-draining rotor case shape they give good volumetric efficiency, exceptionally smooth flow and very low noise even when pumping thinner liquids. The pump shafts do not need to be accurately timed when scimitar rotors are used.

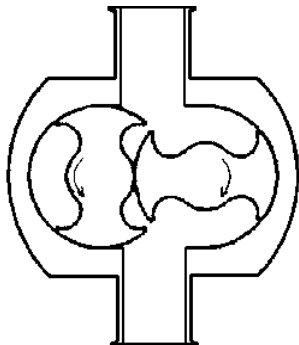

Fig 1

Jabco Hy~Line and Ultima pumps have non-contacting pumping elements, i.e. no contact between the rotors and the casing or cover, or rotor to rotor. The large diameter rigid pump shafts ensure minimal flexing and therefore minimal possibility of any contact which could cause particles to be deposited into the product or roughening of the surface which could compromise cleaning.

Rotor Fixings

Hy~Line pump rotors are securely fixed to their shafts by a flush-faced, sealed screw - Fig 2.

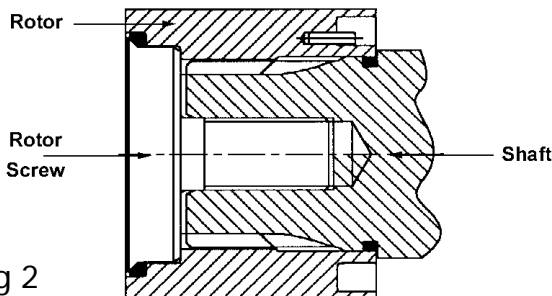

Fig 2

Ultima pumps use a tie rod through the centre of the shaft which completely eliminates the rotor retainer from the product zone - Fig 3.

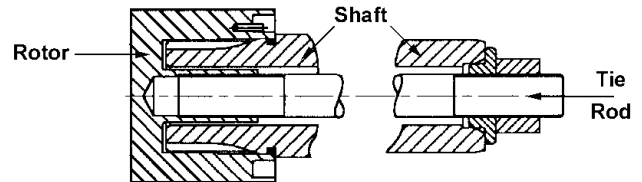

Fig 3

Rotor Options

Depending on pump model, rotors are available with different clearances. Smaller clearances are used for thin liquids at lower pressures. For viscous liquids (over 1000 cP), the largest clearance is normally used for maximum safe working pressure.

Conversions and Interchangeability

Within any one pump size, all rotors are directly interchangeable. At any time, replacement rotors of the same or any other type or clearances can be fitted, it is advisable to check the end clearances and adjust if necessary. Refer to Installation, Operating and Maintenance Manual.

If a pump build specification is changed at any time, the model number must be changed on the pump nameplate to ensure that correct spare parts will be ordered.

Spare Parts

Spare rotors are supplied in boxed pairs.



Hy-Line and Ultima Lobe Pumps

2/00

6.14



<p>Jabsco</p> <hr/>  <p>ITT Industries</p>	<p>USA</p> <p>Jabsco 20 Icon Foothill Ranch CA 92610-3000</p> <p>Tel : +1 949 609 5106 Fax : +1 949 859 1254</p>	<p>UK</p> <p>Jabsco Bingley Road Hoddesdon Hertfordshire, EN11 0BU</p> <p>Tel : +44 (0) 1992 450 145 Fax : +44 (0) 1992 467 132</p>	<p>GERMANY</p> <p>Jabsco GmbH Oststrasse 28 22844 Norderstedt</p> <p>Tel : +49 (0) 40 53 53 73 0 Fax : +49 (0) 40 53 53 73 11</p>
---	--	---	---

Warranty: All products of the company are sold and all services of the company are offered subject to the company's warranty and terms and conditions of sale, copies of which will be furnished upon request. The information provided herein is for guidance only, it does not constitute a guarantee of the performance or specification of any individual product or component.

Single Shaft Seals

Hy~Line and Ultima pumps are fitted with the same high quality mechanical shaft seals to prevent leakage of product from the pump into the atmosphere and to prevent contamination by airborne micro-organisms. All pumps are available with single face seals - Fig 1, and with flushed or double seals as an option; see separate data sheets. This seal design is unique to Hy~Line and Ultima and has a number of features which are of major benefit to the user:

- Hydraulically pressure-balanced
- Crevice-free for highest standards of CIP and SIP capability
- Fully self-draining
- Withstands SIP temperatures and thermal shock
- Solid faces, no metal parts in fluid contact
- No moving parts or springs in fluid contact
- Fitting length pre-set
- Front-loading: seal can be inspected/serviced without removing rotor case
- Anti-rotation device on both faces
- Fully interchangeable parts
- Simple spare parts ordering

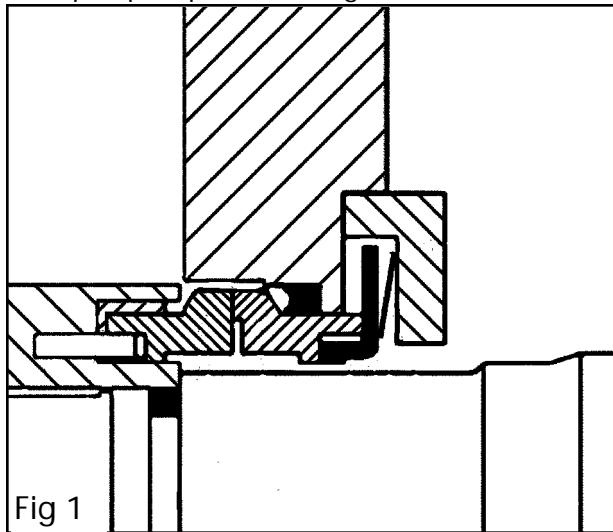

Seal Position and Design

The seal faces are of a balanced design so that the contact pressure between the faces is controlled. This gives excellent sealing even at very low pressures as well as long life at high pressures. Also, the Jabsco pump seal is specially developed to fully expose the sealing faces and the joints around the seal to the fluid. This ensures good circulation of

product to avoid stagnant areas where bacteria can multiply, good cooling of the seal faces and maximum flow of cleaning fluids around the seal. (Other pump types have the seal mounted in a cavity in the rear of the pump which is not easily cleaned due to its inaccessibility). This design also ensures that, when the pump is stopped, fluid can drain from the seal area.

Hy~Line and Ultima pump seals do not use O-rings anywhere in product contact (except certain elastomer options - see Elastomers data sheet) Fig 2 shows the specially developed joint around the rotating seal face. The rotating seat is fitted directly into the back of the rotor to eliminate crevices and the 'L'-section seal cup is slightly flared at its edges "a".

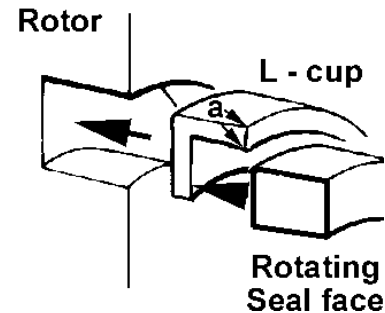

Fig 2

The stationary seat is sealed directly to the rotor case by a ring with a modified square cross-section (except certain elastomer options - see Elastomers data sheet). Both these joints are, in effect, types of gasket. But whereas a flat gasket could allow some penetration of product at its edges when pressurized, these joints prevent this due to the higher contact force where they interface with the product zone. It can be seen quite clearly that these joints are far less likely to harbor bacteria than conventional joints.

Single seals are available in three face material combinations:

Materials and Applications

Carbon on Stainless-Steel	code 8
Carbon on Silicon-Carbide	code 3
Silicon-carbide on Silicon-Carbide	code 2



Hy-Line and Ultima Lobe Pumps

2/00

6.22

The code 8 single carbon on stainless-steel seal is suitable for many clean fluids which do not require a more sophisticated seal type i.e. those which:

- Are non-toxic and non hazardous
- Have some lubricating properties
- Are not highly abrasive
- Have a viscosity less than 150,000 cp
- Do not require steam or sterile fluid (aseptic) barrier
- Do not change state in contact with air i.e. do not, form a film, dry out or precipitate solids
- Are pumped at a temperature less than 180°C (356°F)
- Are not excessively temperature sensitive (do not degrade when heated by the friction of the seal faces)

Note: Ultima pumps are not available with code 8 seals, use code 3 seals.

The code 3 single carbon on silicon carbide seal is used in place of the code 8 single carbon on stainless-steel seal where longer life is required especially if the liquid is non-lubricating. This seal is the first choice for applications where steam sterilization is involved.

The code 2 single Silicon-carbide on Silicon-carbide seal is used where carbon is not acceptable in fluid contact or where face wear would be unacceptable, i.e.

- For abrasive fluids containing crystals, powders or particles which would rapidly wear away the carbon of the standard seal
- Where shedding of particles into the fluid stream must be avoided. The seal faces are the only area in the pump design where rubbing contact is unavoidable. Silicon carbide is extremely hard (only boron carbide and diamond are harder), so the seal does not wear ie, particles are NOT shed into the product

Refer to Pump Selection data sheet for more information on seal selection.

Note that code 2 silicon carbide-on-silicon carbide seals are not recommended for steam-purged applications as the seal faces can bind together - see Cleaning and Sterilizing data sheet.

Installation Procedure

Pumps fitted with single seals require no special installation but pumps must never be run completely dry for more than 30 seconds as this will cause excessive heating of the seal faces. Use flushed seals in pumps that need to run dry. For seal installation and repair, refer to Installation, Operation and Maintenance manual.

Conversions and Interchangeability

Pumps built with single seals can be converted as follows:

- To other face materials e.g. from code 3 to code 2, simply by changing seal faces
- To other elastomer materials. See Elastomers data sheet
- To double or flushed seals. See appropriate data sheet. Conversion kits are available which contain all the parts necessary to convert a single-seal pump to flushed or double seals

Refer to Installation, Operating and Maintenance Manual for instructions on seal removal and fitting.

If a pump build specification is changed at any time, the model number must be changed on the pump name plate to ensure that correct spare parts will be ordered.

Spare Parts

Single seal spare parts are supplied as:

- Primary seal face kits - 2 kits required per pump
- Seal trim kits containing all the elastomer parts for the complete seal - 2 kits required per pump
- Wave springs supplied individually
- Housings supplied individually
- Drive plates supplied individually

When servicing seals, it is not normally necessary to fit new springs and housings. Drive plates should be inspected for wear and replaced as necessary. Face kits do not contain elastomers. Ensure that the correct elastomer trim kits are ordered for the application.

Refer to Spare Parts data sheets for part numbers.

Jabsco



ITT Industries

USA

Jabsco
20 Icon
Foothill Ranch
CA 92610-3000

Tel : +1 949 609 5106
Fax : +1 949 859 1254

UK

Jabsco
Bingley Road
Hoddesdon
Hertfordshire, EN11 0BU

Tel : +44 (0) 1992 450 145
Fax : +44 (0) 1992 467 132

GERMANY

Jabsco GmbH
Oststrasse 28
22844 Norderstedt

Tel : +49 (0) 40 53 53 73 0
Fax : +49 (0) 40 53 53 73 11

Flushed Single Shaft Seals

The flushed seals fitted to Hy~Line and Ultima pumps retain all the features of the single seals, but with the facility to contain a low pressure fluid behind the primary seal. This allows the pump to be used for applications where the single seal alone is unsuitable.

Features of the flushed seals include:

- As easy to assemble and service as single seals
- Share many common parts with single seals

Seal Position and Design

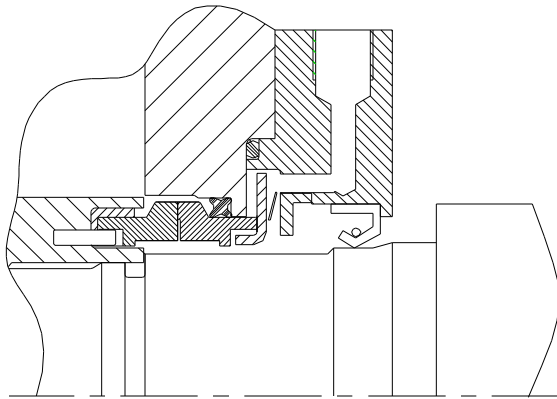

Fig 1

The flushed seal uses a lip seal mounted behind the primary seal - Fig 1. This is fitted into the back of the seal housing and runs on the shaft. In use the space between the primary and lip seals is fed with fluid supplied through pipes connected to drilled holes in the seal housing.

Materials and Applications

Flushed seals are available in three face material combinations:

Carbon on Silicon-carbide	code 5
Silicon-carbide on Silicon-carbide	code 7
Carbon on Stainless steel (Hy~Line only)	code 9

The lip seals are always nitrile.

Flushed seals are run with a low-pressure liquid flush between the primary seal (mechanical face seal) and a lip seal to form a barrier between the pump and the atmosphere.

They are used when

- Pumped fluid changes state in contact with air, e.g. crystallizes, forms a film, dries out or precipitates solids. The flush dissolves and rinses away the small amount of residue which could build up on the edges of the seal faces
- Pumped fluid is hot, i.e. over 80°C (175°F). The flushing fluid is used to cool the seal faces
- Pumped fluid is temperature sensitive and degrades when heated by the shearing action of the seal faces. The flushing fluid is used to cool the seal faces
- Pump must run "dry" for prolonged periods (over 30 seconds), i.e. no liquid in pump chamber
- Pump is under high vacuum
- A low pressure sterile barrier is required

The code 7 flushed Silicon-carbide on Silicon-carbide seal is used where face wear would be unacceptable, i.e.

- For abrasive fluids containing crystals, powders or particles which would rapidly wear away the carbon of the code 5 or 9 seal
- Where shedding of particles into the fluid stream must be avoided

Refer to Pump Selection data sheet for more information on seal selection.

Installation Procedure

A low-pressure flushing fluid system must be installed as follows:-

- Liquid must be compatible with the pumped fluid; water is the most commonly used liquid
- Pressure shall typically be 0.5 bar (7 psi) gauge
- Flush temperature shall be below it's boiling point, ie maximum of 70°C (160°F) for water.
- Flow rate shall preferably be 2 to 3 liters/min. (0.5 to 0.75 US gal/min) per seal
- Flush fluid should be connected to flow in at the lowest point on the seal housing and out at the highest point to vent air pockets, as shown in Fig 2 (overleaf).



Hy-Line and Ultima Lobe Pumps

2/00

6.30

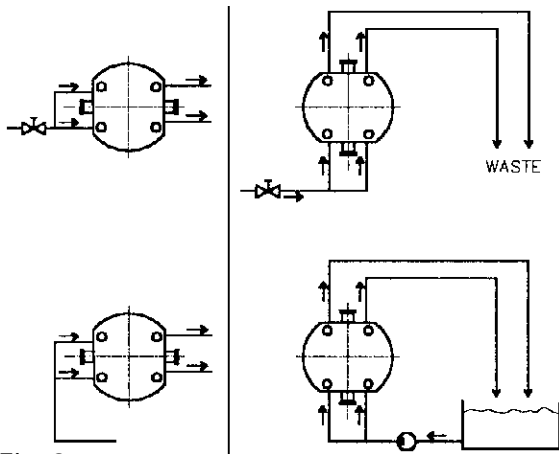

Fig 2

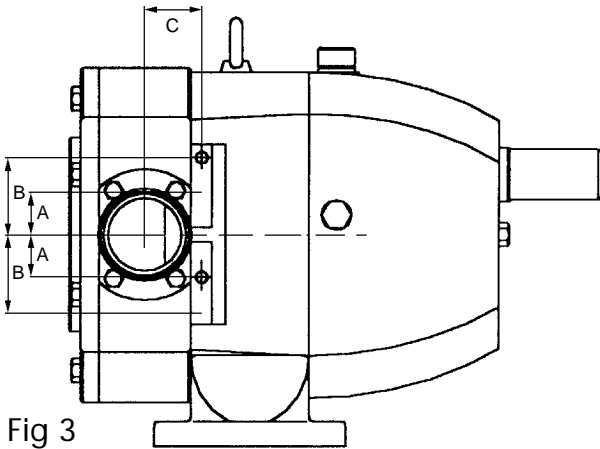

Fig 3

Pump Sizes	42 & 44	52 & 54	62 & 64
A	20.0mm	30.5mm	36.0mm
B	45.0mm	49.5mm	64.0mm
C	38.2/48.2	47.2/66.7	48.4/55.8
Connection Size	1/8" BSP	1/8" BSP	1/8" BSP

Adapters are available to convert connections to 1/8 NPT
 For seal installation and repair, refer to installation, operation and maintenance manual.

Conversions and Interchangeability

Pumps built with flushed seals can be converted as follows:

- To other face materials e.g. from code 5 to code 7
- To other elastomer materials, see Elastomers data sheet
- To single seals, simply by removing the lip seal
- To double seals - see Double Seals data sheet. A conversion kit is available which contains all the parts necessary to convert a pump to double seals

Refer to Installation, Operating and Maintenance Manual for instructions on seal removal and fitting.

If a pump build specification is changed at any time, the model number must be changed on the pump nameplate to ensure that correct spare parts will be ordered.

Double seal spare parts are supplied as:

Spare Parts

- Primary seal face kits - 2 kits required per pump
- Lip seals - 2 required per pump
- Seal trim kits containing all the elastomer parts for the complete seal - 2 kits required per pump
- Springs supplied individually
- Housings supplied individually

When servicing seals, it is not normally necessary to fit new springs and housings. Drive plates should be inspected for wear and replaced as necessary. Face kits do not contain elastomers. Ensure that the correct elastomer trim kits are ordered for the application.

Refer to Spare Parts data sheets for part numbers.

Jabsco



ITT Industries

USA

Jabsco
 20 Icon
 Foothill Ranch
 CA 92610-3000

Tel : +1 949 609 5106
 Fax : +1 949 859 1254

UK

Jabsco
 Bingley Road
 Hoddesdon
 Hertfordshire, EN11 0BU

Tel : +44 (0) 1992 450 145
 Fax : +44 (0) 1992 467 132

GERMANY

Jabsco GmbH
 Oststrasse 28
 22844 Norderstedt

Tel : +49 (0) 40 53 53 73 0
 Fax : +49 (0) 40 53 53 73 11

Double Shaft Seals

The double seals fitted to Hy-Line and Ultima pumps retain all the features of the single seals, but with the facility to contain a high pressure fluid behind the primary seal. This allows the pump to be used for applications where the single seal is unsuitable. Features of the double seals include:

- Highly effective sealing of flushing fluids
- Can be used with steam aseptic barrier
- As easy to assemble and service as single seals
- Share many common parts with single and flushed seals

Seal Position and Design

The double seal uses a pair of seal faces (secondary seal) mounted behind the primary seal - Fig 1. One face is fitted into the back of the special seal housing and the other fits onto the shaft. The primary seal wave spring also acts on the secondary seal to keep these faces together

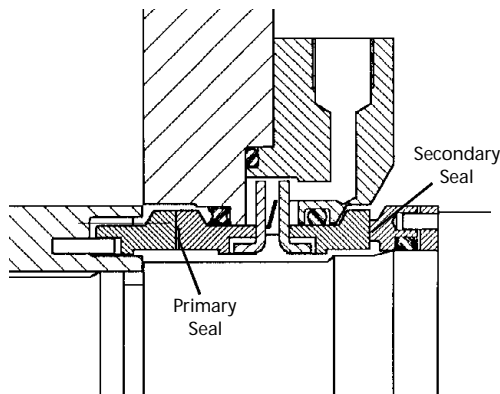

Fig 1

In use the space between the primary and secondary seals is fed with fluid or steam supplied through pipes connected to drilled holes in the seal housing.

Materials and Applications

Double seals are available in two primary seal face material combinations:

Carbon on Silicon-carbide	code 4
Silicon-carbide on Silicon-carbide	code 1

In all double seals, secondary faces are always Carbon on Silicon-carbide.

Double seals Codes 1 and 4 are run with a fluid between the primary and secondary seals to form a barrier between the pump and the atmosphere.

They are used with:

A low-pressure liquid flush when:

- The pumped fluid is toxic or hazardous and must not escape from pump even in minute quantities

A high-pressure liquid flush when:

- The pumped fluid has no lubricating properties and cannot be allowed onto seal faces
- Pumped fluid is highly viscous, over 150,000 cp
- A high pressure sterile liquid barrier is required

or steam when:

- No bacteria or contamination can be allowed to enter pump, i.e. an aseptic barrier

The code 1 double Silicon-carbide on Silicon-carbide seal is used where face wear would be unacceptable, i.e.

- For abrasive fluids containing crystals, powders or particles which would rapidly wear away the carbon of the code 4 seal
- Where shedding of particles into the fluid stream must be avoided

Installation Procedure

Refer to Pump Selection data sheet for more information on seal selection.

When the double seal is used with a high-pressure flush for the reasons described above, a flushing system must be installed as follows:

- The flushing liquid used must itself be compatible with the pumped fluid and must itself not require a complex seal, i.e. must be non hazardous, non abrasive and lubricating
- Flush liquid must be at a pressure of 1 bar (15psi) above the discharge pressure of the Jabsco lobe pump and should flow at 35 to 55 liters/hour (10 to 15 US gal/hour) per seal
- Flush fluid should be connected to flow in at the lowest point on the seal housing and out at the highest point to vent air pockets
- See Fig 2 for suggested flush system

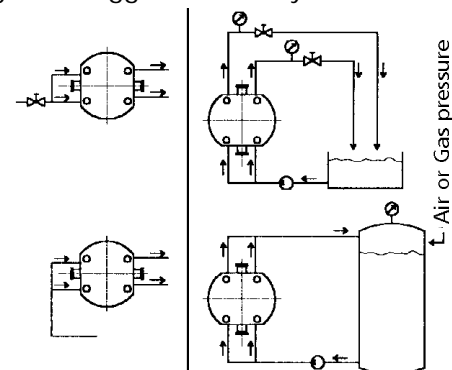

Fig 2

When the double seal is used with a steam barrier:

- wherever possible, sterile liquid e.g. steam condensate should be used as a flush. Condensate should be connected to flow in at the lowest point on the seal housing and out at the highest point to vent air pockets, see (a) above
- where steam is essential, great care must be taken with the design of pipework, steam traps and controls
- steam must be clean, filtered and wet, i.e. not super heated
- the pressure of steam should be as low as possible consistent with the desired temperature
- steam should be connected in at the highest point on the seal housing and out at the lowest point to allow any condensate to drain fully
- see Fig 3 for suggested steam connections:

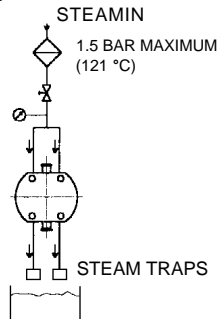

Fig 3

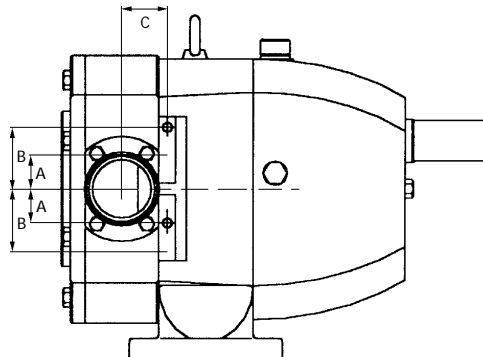

Fig 4

Pump Sizes	42 & 44	52 & 54	62 & 64
A	20.0mm	30.5mm	36.0mm
B	45.0mm	49.5mm	64.0mm
C	38.2/48.2	47.2/66.7	48.4/55.8
Connection Size	1/8" BSP	1/8" BSP	1/8" BSP

Adapters are available to convert connections to 1/8" NPT

Conversions and Interchangeability

For seal installation and repair, refer to installation, operation and maintenance manual. Pumps built with double seals can be converted as follows:

- To other face materials e.g. from code 1 to code 4
- To other elastomer materials, see Elastomers data sheet
- To single seals, simply by removing the secondary seal faces and joint rings. See Single Seals data sheet
- To single flushed seals. See Single Flushed Seals data sheet. A conversion kit is available which contain all the parts necessary to convert a pump to flushed seals

Refer to Installation, Operating and Maintenance Manual for instructions on seal removal and fitting. If a pump build specification is changed at any time, the model number must be changed on the pump nameplate to ensure that correct spare parts will be ordered.

Spare Parts

Double seal spare parts are supplied as:

- Primary seal face kits - 2 kits required per pump
- Secondary seal face kits - 2 kits required per pump
- Seal trim kits containing all the elastomer parts for the complete seal - 2 kits required per pump
- Springs supplied individually
- Housings supplied individually

When servicing seals, it is not normally necessary to fit new springs and housings. Drive plates should be inspected for wear and replaced as necessary. Face kits do not contain elastomers. Ensure that the correct elastomer trim kits are ordered for the application

Refer to Spare Parts data sheets for part numbers.

Jabsco



ITT Industries

USA

Jabsco
20 Icon
Foothill Ranch
CA 92610-3000

Tel : +1 949 609 5106
Fax : +1 949 859 1254

UK

Jabsco
Bingley Road
Hoddesdon
Hertfordshire, EN11 0BU

Tel : +44 (0) 1992 450 145
Fax : +44 (0) 1992 467 132

GERMANY

Jabsco GmbH
Oststrasse 28
22844 Norderstedt

Tel : +49 (0) 40 53 53 73 0
Fax : +49 (0) 40 53 53 73 11

Single 'O' Ring Seals (Hy~Line only)

This seal is designed as a low cost shaft-sealing device and utilizes a single Viton O-ring working under dynamic conditions.

Seal Position and Design

The O-ring is housed in a removable housing mounted to the front of the rotor case in the same way as the mechanical face type seals. A sleeve is fitted into the rotor and rotates with the rotor and shaft assembly. The O-ring remains static in the housing and the sleeve rotates against the inner diameter of the O-ring. See figure 1

Materials and Applications

This type of seal can be used for products that are non-abrasive and have some lubricating properties of their own. e.g. oil based products. Because of the narrow sealing surface that the O-ring presents against the sleeve, it can also be used for products that have a tendency to polymerize (ball up). This polymerization occurs due to frictional heat generated between the faces of a normal mechanical face type seal and would require a double mechanical seal system with an expensive pressurized flushing system. The O-ring seal does not need this expensive flushing system.

Maximum Operating Conditions: -

- 6 bar system pressure
- Up to maximum pump speed
- Temperature range - 0°C to 100°C

Typical products are: -

- Milk
- Yogurt
- Dairy creams
- Latex

It has also been found to give excellent results with:-

- Jams (conserves)
- Glucose solutions

These seals must be used in conjunction with normal chemical resistance guidelines and should not be allowed to run dry. i.e. without product in the pump.

Installation Procedure

The single O-ring can be installed very easily without any rotor case modification. (See Installation, Operating and Maintenance manual). Once installed the primary sealing O-ring can be removed from the front of the pump without removing the rotor case and without disturbing the pipe system. If it becomes necessary, the sleeve upon which the O-ring runs can also be removed without cause to disturb the rotor case or pipe system.

Conversion and Interchangeability

The single O-ring seal is fully interchangeable with all mechanical seal types without any modification to other components, e.g. rotor case. See spare parts list for conversion kit.

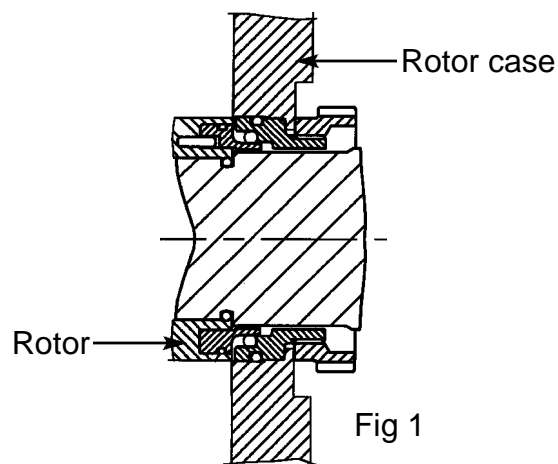

Spare Parts

It is important to establish O-ring lifetime by trials and a planned O-ring replacement program initiated. Due to the low costs and ease with which the O-rings can be changed this replacement program can easily be co-ordinated with regular manual cleaning or inspection.

Spare O-rings can be supplied. (See spare parts list).



Hy ~ Line and Ultima Lobe Pumps

4/00

6.40



Jabsco



ITT Industries

USA

Jabsco
20 Icon
Foothill Ranch
CA 92610-3000

Tel : +1 949 609 5106
Fax : +1 949 859 1254

UK

Jabsco
Bingley Road
Hoddesdon
Hertfordshire, EN11 0BU

Tel : +44 (0) 1992 450 145
Fax : +44 (0) 1992 467 132

GERMANY

Jabsco GmbH
Oststrasse 28
22844 Norderstedt

Tel : +49 (0) 40 53 53 73 0
Fax : +49 (0) 40 53 53 73 11

Double 'O' Ring Seals (Hy~Line only)

Seal Position and Design

This seal utilizes 2 Viton O-rings running under dynamic conditions against a rotating shaft sleeve fitted into the pump rotor, see Fig1. It's function is similar to a single flushed mechanical shaft seal in that the primary O-ring (product side) replaces the mechanical shaft seal and the secondary O-ring (atmosphere side) replaces the lip seal. In a similar way to the single O-ring (See data sheet 6.39), it is a low cost sealing device where the O-ring can be replaced from the front of the pump without the need to remove the rotor case.

Materials and Applications

This type of seal can be used for most fluid types providing a suitable flushing medium is fed between the 2 O-rings. It can also be used in the same situations as the single O-ring seal (See data sheet 6.39) but where dry running may be experienced as the flushing medium acts as a lubricant to avoid burning up of the O-rings.

Maximum Operating Conditions: -

- 6 bar system pressure
- Up to maximum pump speed
- Temperature range - 0°C to 100°C

Typical products are :-

- Jams (conserves)
- Crystallising products e.g. Sugar solutions
- High undissolved sugar content products e.g. biscuit cream, slurries
- As a "Dry Running" version of the single O-ring seal (see data sheet 6.39)

These seals must be used in conjunction with normal chemical resistance guidelines.

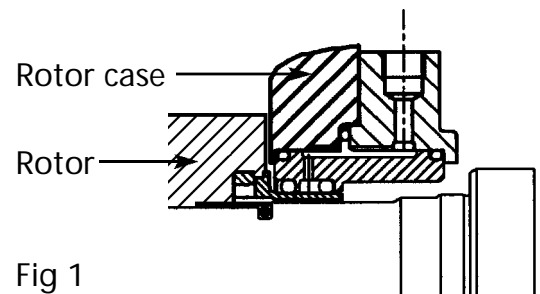

Installation Procedure

The double O-ring seal requires a modified rotor case so cannot be directly interchanged with other seal types. The secondary O-ring cannot be replaced from the front of the pump, however the primary O-ring can be replaced from the front of the pump without disturbing the rotor case or pipe system. The double O-ring seal is designed such that the cavity between the primary and secondary O-ring can be flushed, charged or pressurized in the following way: -

- Grease packed (food grade where appropriate) between the primary and secondary O-rings in order to avoid dry running problems of a single O-ring seal. A small top up system will be required in order to replenish lost grease, e.g. grease nipples.
- A pressurized grease system using a commercially available grease canister. This offers the ability to seal against abrasive products such as high sugar products. It must be recognized that a small amount of grease will leak into the product being pumped. It will be necessary therefore to select compatible grease. (See fig 2, below).

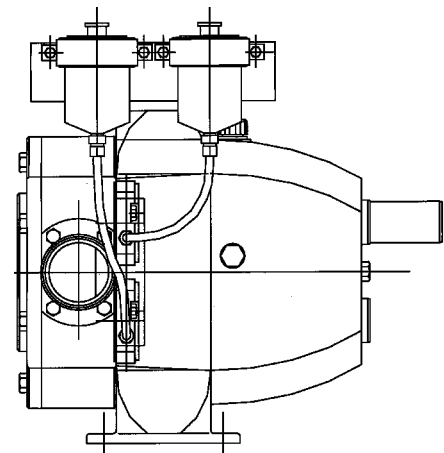

Fig 2

- An open flow low pressure flushing system where the flushing medium is re-circulating or going to waste. (See fig 3) This type of system can be used in the same applications as a single flushed mechanical seal. (See data sheet 6.29).



Hy-Line and Ultima Lobe Pumps

4/00

6.42

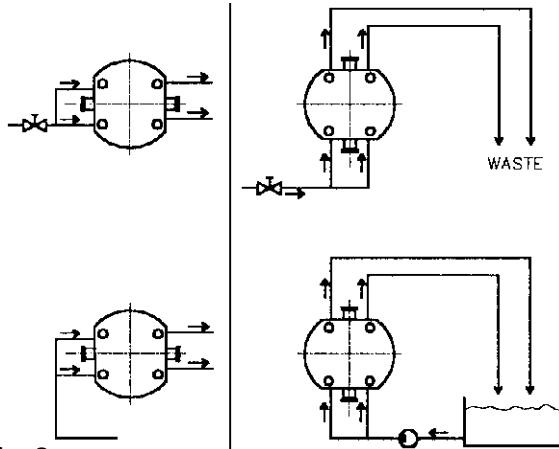

Fig 3

Conversion and Interchangeability

In order to convert any mechanical seal to double O-ring seal it is necessary to modify the rotor case (modified rotor case available- see spare parts list).

All parts required for conversion are available as a kit (see spare parts list).

Spare Parts

The only wearing parts within this seal design are the primary and secondary O-rings and occasionally the sleeve may require replacement. The frequency of this replacement is a factor of pump speed, pressure, duty and product being pumped and can only be established by trial and error. All parts are available as separate items. (See spare parts list).

Jabsco



ITT Industries

USA

Jabsco
20 Icon
Foothill Ranch
CA 92610-3000

Tel : +1 949 609 5106
Fax : +1 949 859 1254

UK

Jabsco
Bingley Road
Hoddesdon
Hertfordshire, EN11 0BU

Tel : +44 (0) 1992 450 145
Fax : +44 (0) 1992 467 132

GERMANY

Jabsco GmbH
Oststrasse 28
22844 Norderstedt

Tel : +49 (0) 40 53 53 73 0
Fax : +49 (0) 40 53 53 73 11

Multiple PTFE Lip Seals (Hy~Line only)

Seal Position and Design

This seal utilizes 3 or 4 PTFE lip seals (depending on pump size) fitted into a housing in the rotor case and running on a shaft sleeve fitted into the rotor (see fig 1).

The system is supplied complete with a controlled release food grade grease feed system.

For operation of this seal, a constant feed of food grade grease is required in order to avoid back flow of product into the seal area and to lubricate the seals themselves.

The function of this seal is as follows:

The PTFE lip seals are positioned such that they are sealing against the product being pumped. Introduction of a food grade grease at a controlled rate from the 2 mini-luber grease canisters allow the grease to feed under the lip seals and into the product. The feed rate is typically 250ml per seal over a 3-6 month period, i.e. contamination of the product is extremely small. This small leakage of grease offers good lubrication of the seals and ensures that no product is allowed to get between the seals. The pressure generated by the grease feed system is 6 Bar. (See fig 2)

Materials and Application

This is the ideal low cost seal for chocolate or other products with a high percentage of undissolved solids e.g. biscuit cream.

- Seal materials - Food grade PTFE
- Grease - Food grade grease

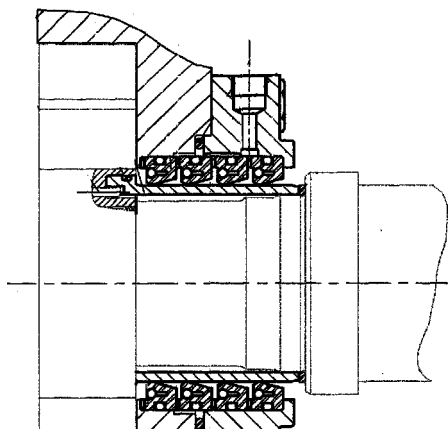

Fig 1

Installation Procedure

This seal is supplied complete with the grease feed system. No special other installation is required. The grease feed system should initially be set to 3 months. Further adjustments of the feed rate can be made to optimize the replacement period of the grease canisters. This can only be achieved by trials

Conversion and Interchangeability

In order to convert any mechanical seal design to multiple seal it is necessary to modify the rotor case (modified rotor case available- see spare parts list) All parts required for conversion are available as a spare parts list (see spare parts list)

Spare Parts

Removal of the rotor case is required in order to remove and replace the lip seals. Replacement period is approximately 1 year. Inspection of the condition of the lip seals and the sleeve may indicate that longer seal life can be achieved.

Grease canisters **MUST** be changed **BEFORE** they are empty in order to avoid loss of grease pressure and subsequent ingress of product between the seal resulting in the premature wearing of the seal and sleeve.

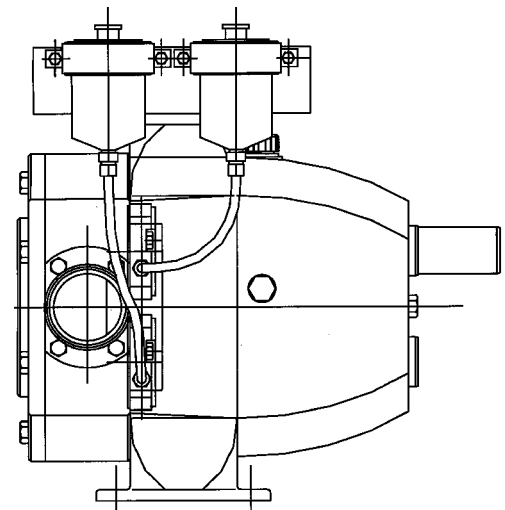

Fig 2



Hy-Line and Ultima Lobe Pumps

4/00

6.44

Dimensional drawing

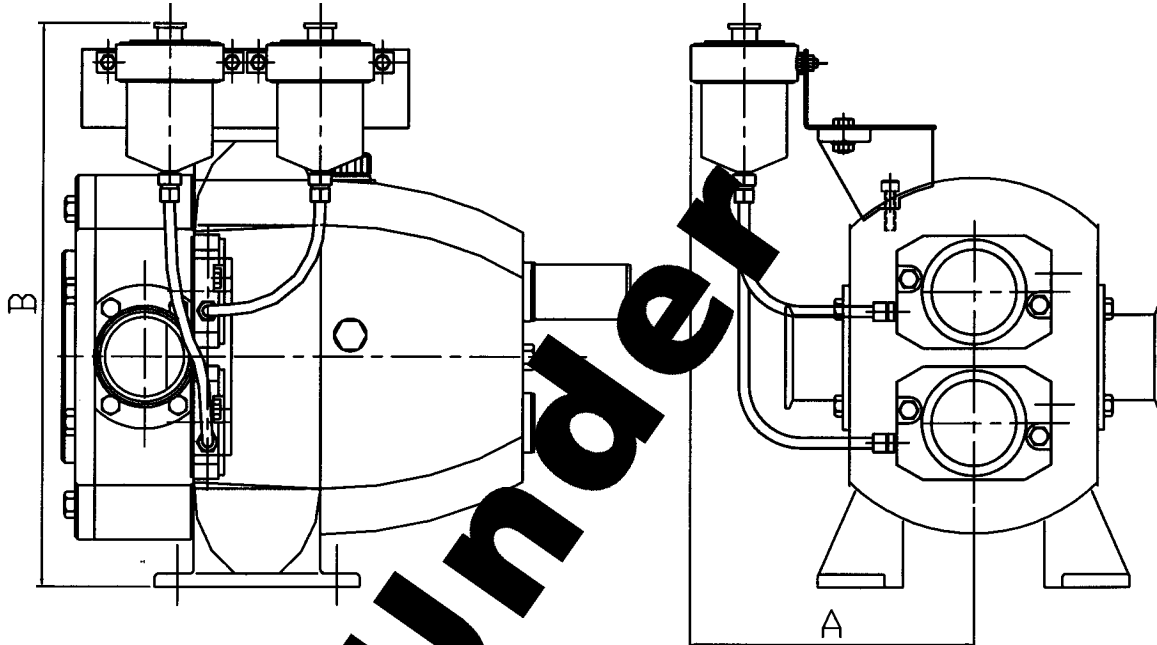

Pump size	42	44	52	54	62	64
A	189	189	205	205	218	218
B	280	280	320	320	430	430

Jabsco



ITT Industries

USA

Jabsco
20 Icon
Foothill Ranch
CA 92610-3000

Tel : +1 949 609 5106
Fax : +1 949 859 1254

UK

Jabsco
Bingley Road
Hoddesdon
Hertfordshire, EN11 0BU

Tel : +44 (0) 1992 450 145
Fax : +44 (0) 1992 467 132

GERMANY

Jabsco GmbH
Oststrasse 28
22844 Norderstedt

Tel : +49 (0) 40 53 53 73 0
Fax : +49 (0) 40 53 53 73 11



Elastomers

In a Hy~Line pump there are 9 sealing components in contact with the pumped fluid. In an Ultima pump there are only 5 joints as there is no internal rotor fixing, and all of these are specially molded gasket-type joints. Great care is taken in the manufacture of the seals to ensure that there are no imperfections on the surfaces which can harbor bacteria and the design of the moulds is such that there is no moulding flash on critical sealing edges.

Materials and Standards

Hy~Line and Ultima pumps can be specified with up to 4 alternative sealing materials:

Nitrile - This 3A-grade nitrile has a good balance of properties and is resistant to many chemicals as well as oil and fat-based products. Nitrile-trim Hy~Line pumps use an O-ring to seal the stationary seal face to the rotor case seal bore. Ultima pumps are not available with Nitrile elastomers. See Fig 1 overleaf

EPDM - This peroxide cured grade of EPDM conforms to the requirements of the US FDA Code of Federal Regulations Title 21 section 177.2600 "Rubber Articles Intended for Repeated Use". This material is chosen for its excellent resistance to water-based solutions, and particularly to hot water and steam, and also for its acceptability in contact with pharmaceutical products, foods etc. EPDM is not suitable for contact with mineral oils. See Fig 2 overleaf

Viton® - generic name F.P.M. This grade of Viton® conforms to the requirements of the US FDA Code of Federal Regulations Title 21 section 177.2600 "Rubber Articles Intended for Repeated Use". This Viton® has excellent resistance to many chemicals, oils and solvents and also has a wide operating temperature range. It is less suitable for SIP (steam-in-place) applications. See Fig 2 overleaf

PTFE - often called Teflon®. PTFE has exceptional resistance to chemicals. Both Hy~Line and Ultima utilize a PTFE encapsulated Viton® O-ring to seal the static face to the rotor case. The seal

face in the rotor sits on a viton washer (not in contact with the pumped product) and is housed in a virgin PTFE sleeve which is pressed into the rotor. These 2 components replace the normal L-cup. The end cover joint is a solid O-ring (Hy~Line) or a gasket (Ultima) and port joints are also solid PTFE (Hy~Line). Note that PTFE joints must be replaced regularly especially if subjected to wide temperature variations eg steam-in-place (SIP). All solid PTFE components conform to the US FDA Code of Federal Regulations Title 21 section 177.1550, See Fig 3 overleaf.

Material	Temperature Range	Conformance to Standards	Model Number Suffix
Nitrile	-30 to +110°C -22 to +230°F	US 3-A 18-03	None
EPDM	-35 to +140°C -31 to +285°F	US FDA CFR 21 177.2600	E
Viton [®]	-25 to +180°C -13 to +355°F	US FDA CFR 21 177.2600	V
PTFE-20	+180°C -4 - +355°F	US FDA CFR 21 177.1550	P

For full details of material compatibility, refer to Jabsco Liquid Compatibility Guide, publication number SD932.

Conversions and Interchangeability

Pumps can easily be converted to other elastomer specifications by ordering a complete pump head trim kit. Refer to Installation, Operating and Maintenance Manual for instructions on seal removal and fitting.

If a pump build specification is changed at any time, the model number must be changed on the pump nameplate to ensure that correct spare parts will be ordered.



Hy~Line and Ultima Lobe Pumps

2/00

6.46

Spare Parts

Elastomer spares can be ordered as:

- Pump Head trim kit - consists of all the elastomer parts required for one complete pump.

OR:

- Seal trim kit - containing all the elastomer parts for one complete seal - 2 kits required per pump
- End cover joint ring (O-ring for Hy~Line pumps) - supplied individually
- Rotor screw O-rings - 2 required per pump (not required for Ultima pumps)
- Port-to-rotor-case joint ring - 2 required per pump (not required for Ultima pumps)

Refer to Spare Parts data sheets for part numbers.

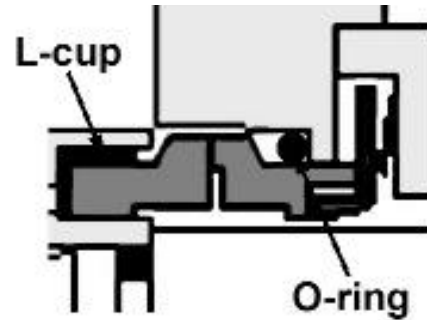

Fig 1 - Nitrile

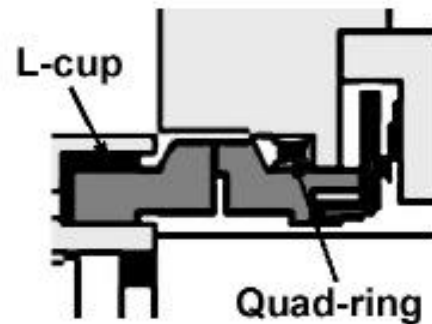

Fig 2 - Viton & EPDM

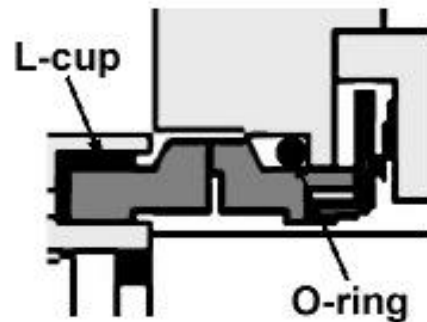

Fig 3 - PTFE

Jabsco



ITT Industries

USA

Jabsco
20 Icon
Foothill Ranch
CA 92610-3000

Tel : +1 949 609 5106
Fax : +1 949 859 1254

UK

Jabsco
Bingley Road
Hoddesdon
Hertfordshire, EN11 0BU

Tel : +44 (0) 1992 450 145
Fax : +44 (0) 1992 467 132

GERMANY

Jabsco GmbH
Oststrasse 28
22844 Norderstedt

Tel : +49 (0) 40 53 53 73 0
Fax : +49 (0) 40 53 53 73 11

End Covers

The standard Hy~Line and Ultima end covers are completely flat. This ensures that there are no crevices where contaminants can collect and that the pump can easily be cleaned in place. The end cover is held in place by bolts and can easily be removed for inspection of the pump head and for servicing.

The Hy~Line end cover is sealed to the rotor case by an O-ring in a groove precisely-machined in the end-cover which minimizes product retention and assists in effective CIP - Fig 1.

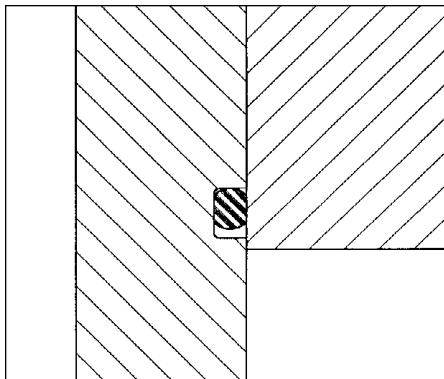

Fig 1

The Ultima end cover does not use an O-ring. Instead it is sealed by a special gasket type joint ring, fitted in a groove machined in the front face of the rotor case - Fig 2. There are no crevices at all in the fluid-contact area and there is no groove in the end cover. This joint ring has flared edges to ensure excellent sealing against product leakage and ingress of airborne bacteria. It is a controlled-compression design to prevent extrusion due to overtightening and there is allowance behind the ring for thermal expansion. In combination these features contribute to Ultima's exceptionally high CIP capability.

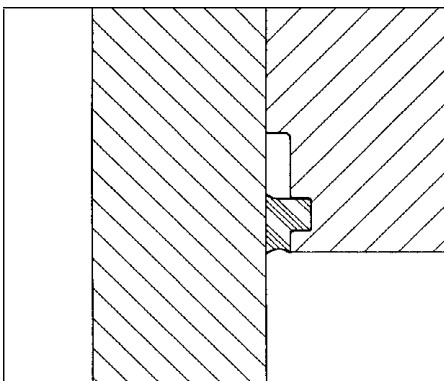

Fig 2

Refer to Elastomers data sheet for material availability.

End Cover Sterile Barrier

Ultima models may also be fitted with an end cover to accommodate an aseptic barrier of sterile liquid or steam - Fig 3. This can be specified at the time of ordering the pump by using code 5 for the end-cover in the model number.

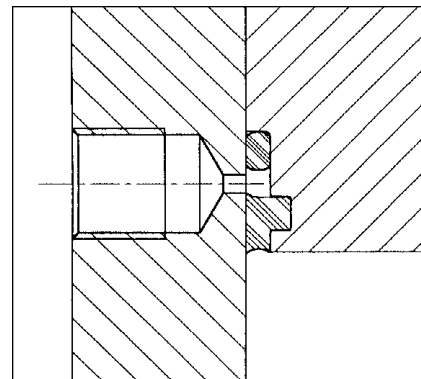

Fig 3

Existing pumps can be modified by changing the end cover. The end-cover barrier will normally only be used in conjunction with double seals. The barrier fluid is connected in a similar way - Fig 4.

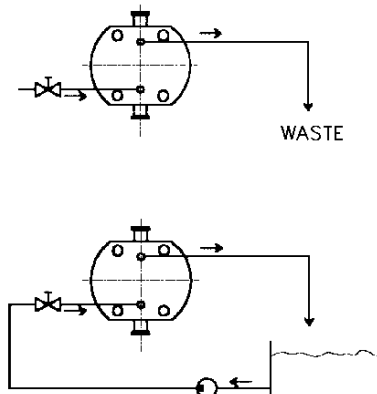

Fig 4

End Cover Relief Valve

See separate data sheet - Relief Valve, 6.55.

End Cover Temperature Control Jackets

See separate data sheet - Temperature Control Jackets, 6.77.



Hy-Line and Ultima Lobe Pumps

2/00

6.54

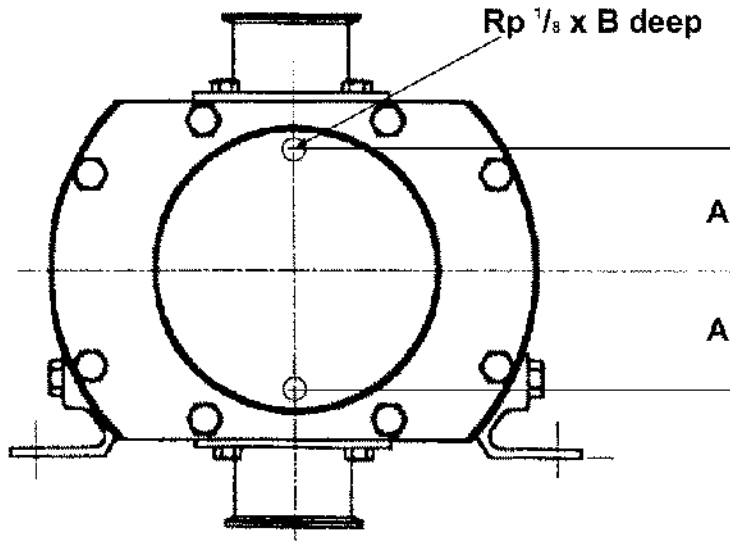

Pump Size	A mm	B mm
42/44	50.9	8
52/54	59.5	10
62/64	73	8

Jabsco



ITT Industries

USA

Jabsco
20 Icon
Foothill Ranch
CA 92610-3000

Tel : +1 949 609 5106
Fax : +1 949 859 1254

UK

Jabsco
Bingley Road
Hoddesdon
Hertfordshire, EN11 0BU

Tel : +44 (0) 1992 450 145
Fax : +44 (0) 1992 467 132

GERMANY

Jabsco GmbH
Oststrasse 28
22844 Norderstedt

Tel : +49 (0) 40 53 53 73 0
Fax : +49 (0) 40 53 53 73 11

End Cover Relief Valve

Hy~Line pumps can be fitted with an end cover relief valve which can be set to protect the PUMP ONLY from overpressure. This valve is not designed to protect the system or to provide long term by-pass of liquid. If this is required then an IN-LINE relief valve should be fitted which can by-pass the liquid back to the suction vessel during overpressure situations.

Features of the end cover relief valve include :

- Simple pump protection device
- Easy to fit and to set
- No 'dead leg' or by-pass loops
- 80% 'crack' pressure, no seeping
- Full by-pass of liquids up to 5,000 cP

Position and Design

The relief valve is simply fitted onto the rotor case (pump body) in place of the standard end cover. In order to achieve the best operating parameters the valve is designed to operate in ONE DIRECTION ONLY.

The function is as follows – a channel is connected between the discharge side of the pump and the centre of the diaphragm. Behind the diaphragm is a spring loaded piston. As the pressure on the discharge side of the pump increases it reaches a point where the spring load is overcome. At this point the diaphragm is lifted off of its seat. This exposes the full area of the diaphragm to the discharge pressure which in turn increases the load to the piston by a factor 5 or more. Due to this sudden increase in load the valve opens fully and allows the product to by-pass back to the suction side of the pump via another channel. The valve does not close again until the discharge pressure drops to approx 10% of the pressure required to 'crack' open the valve. It may be necessary to stop the pump.

The spring load can be manually adjusted to give different opening pressures of the valve up to the maximum pressure capability of the pump. See fig 1.

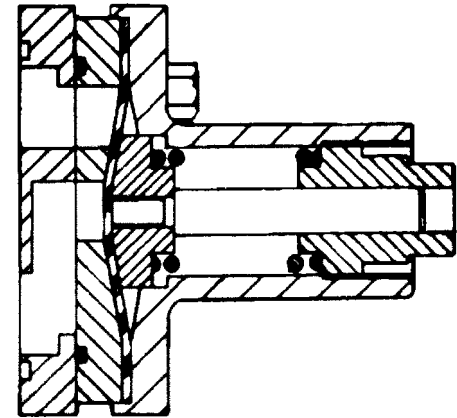

Fig 1

Materials and Operating Parameters

Diaphragm	- Food grade 3A Nitrile - PTFE faced fluoroelastomer
Housing	- 316 Stainless Steel
Spring	- Stainless Steel
Max Temp	- Nitrile +110 °C - PTFE +200 °C
Max Pressure	- 15 bar
Max Viscosity	- Dependant on flow through pump. Up to 5000 cP if full capacity of pump required. Greater viscosities are possible at lower flow rates or if product is shear thinning.

Installation Procedure

The valve will only work in one direction of flow, a 'Direction of Flow' arrow is attached to the cover. The cover MUST be fitted with this arrow facing in the correct direction. The procedure for setting the opening pressure of the valve is shown in the Installation, Operating and Maintenance Manual no 43010-0201 Section 2.12

Spare Parts

Parts are available as individual items or as a kit of parts (O-ring and Diaphragm)
Refer to Spare Parts data sheets for part numbers



Hy-Line and Ultima Lobe Pumps

2/00

6.56

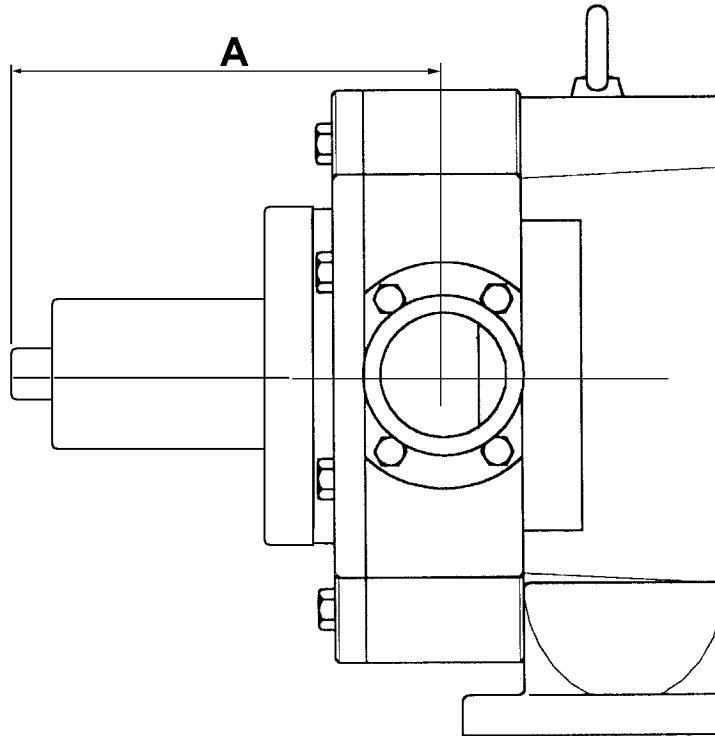

Pump	42	44	52	54	62	64
Dim A	163	169	191	200	264	284

Jabsco



ITT Industries

USA

Jabsco
20 Icon
Foothill Ranch
CA 92610-3000

Tel : +1 949 609 5106
Fax : +1 949 859 1254

UK

Jabsco
Bingley Road
Hoddesdon
Hertfordshire, EN11 0BU

Tel : +44 (0) 1992 450 145
Fax : +44 (0) 1992 467 132

GERMANY

Jabsco GmbH
Oststrasse 28
22844 Norderstedt

Tel : +49 (0) 40 53 53 73 0
Fax : +49 (0) 40 53 53 73 11



Port Connections

Hy~Line pumps utilize a system of bolt-on ports pioneered by Jabsco. This enables the customer to order pumps, and even change ports later, to suit most common National and International pipe connection systems - Fig 1.

Port connection types available for Hy~Line pumps	Ordering code
Tri-Clamp - BS 4825 : Part 3	1
Male screwed BS parallel pipe thread to BS 2779 DIN 259, ISO 7/1 : 1982	2
ISS/IDF (International Dairy Federation) to ISO 2853 - BS 4825 : Part 4	3
RJT (British Milk) to BS 4825 : Part 5	4
3A Acme Bevel Seat	5
DIN 11851	6
SMS 1146	7
NPT male screwed taper pipe thread - ANSI B2.1	9

Also, many pumps are available with 2 or even 3 diameters of connection to match the installation pipe size, even when pumping viscous liquids. See table overleaf.



Fig 1

Each port is sealed to the pump by a specially molded crevice free joint ring to avoid any bacteria traps - Fig 2. This is supplied in a range of materials - see Elastomers data sheet.

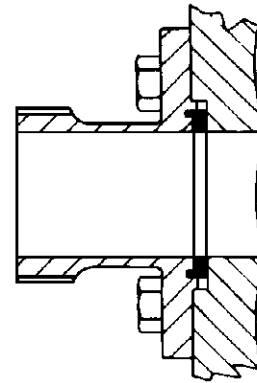

Fig 2

The ports of Ultima pumps are welded directly to the rotor case by a precision orbital welding technique which guarantees full weld penetration without crevices. Rotor case port connections utilize the Tri-clamp connection as standard. Other hygienic types can be accommodated by adapters, or welded to special order.



Hy-Line and Ultima Lobe Pumps

2/00

6.62

Code	Type	Size	Port Size - inch or millimeter as appropriate					
			42	44	52	54	62	64
1	Tri-Clamp	Reduced	-	-	-	-	2	-
		Standard	1	1½	1½	2	2½	3
		Enlarged	1½	2	2	3	3	4
2	BSP (Male)	Reduced	-	-	-	-	2	-
		Standard	1	1½	1½	2	2½	3
		Enlarged	1½	2	2	3	3	4
3	IDF	Reduced	-	-	-	-	2	-
		Standard	1 (25)	1½ (38)	1½ (38)	2 (51)	2½ (63.5)	3 (76.1)
		Enlarged	1½ (38)	2 (51)	2 (51)	3 (76.1)	3 (76.1)	4 (101.6)
4	BSP (Male)	Reduced	-	-	-	-	2	-
		Standard	1	1½	1½	2	2½	3
		Enlarged	1½	2	2	3	3	4
5	3A Bevel Seat	Reduced	-	-	-	-	2	-
		Standard	1	1½	1½	2	2½	3
		Enlarged	1½	2	2	3	3	4
6	DIN	Reduced	-	-	-	-	50	-
		Standard	25	40	40	50	65	80
		Enlarged	40	50	50	80	80	100
7	SMS	Reduced	-	-	-	-	51	-
		Standard	25	38	38	51	63.5	76
		Enlarged	38	51	51	76	76	108
9	NPT (Male)	Reduced	-	-	-	-	2	-
		Standard	1	1½	1½	2	2½	3
		Enlarged	1½	2	2	3	3	4

Jabsco



ITT Industries

USA

Jabsco
20 Icon
Foothill Ranch
CA 92610-3000

Tel : +1 949 609 5106
Fax : +1 949 859 1254

UK

Jabsco
Bingley Road
Hoddesdon
Hertfordshire, EN11 0BU

Tel : +44 (0) 1992 450 145
Fax : +44 (0) 1992 467 132

GERMANY

Jabsco GmbH
Oststrasse 28
22844 Norderstedt

Tel : +49 (0) 40 53 53 73 0
Fax : +49 (0) 40 53 53 73 11

Enlarged Rectangular Inlet

Pumps are also available with enlarged rectangular (hopper) inlet - Fig 1. This is used for pumping liquids which are so viscous that they will not flow through any inlet pipe fast enough to fill the pump at the desired running speed. The largest possible opening is machined in the side of the rotor case to allow a hopper (not supplied with pump) to be bolted directly to the face. Alternatively, an auger screw feeder can be adapted to this face to force product into the pump inlet.

Rectangular Inlet pumps are normally supplied assembled for vertical pipe orientation.

The weight of the hopper (and the product it contains) must be supported separately and not allowed to rest entirely on the pump as this would affect the rotor clearances leading to pump seizure.

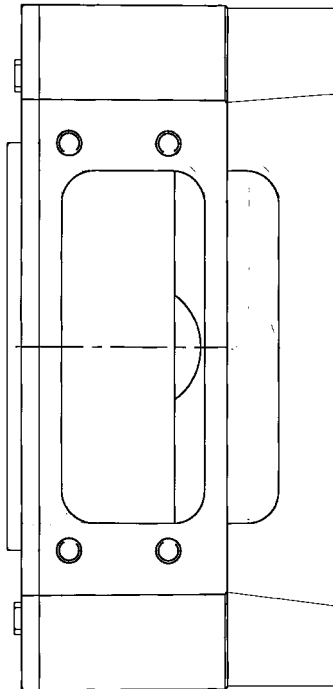

Fig 1

Dimensions of rectangular inlet:

The mating flange of a hopper or screw feeder should be machined to the identical dimensions to avoid ledges where product could 'hang up'.

The position of the center line of the hopper inlet is the same as the center line of the port. See below.

The enlarged inlet port is on the right side of the rotor case when viewed from the front cover of the pump. (top shaft drive)

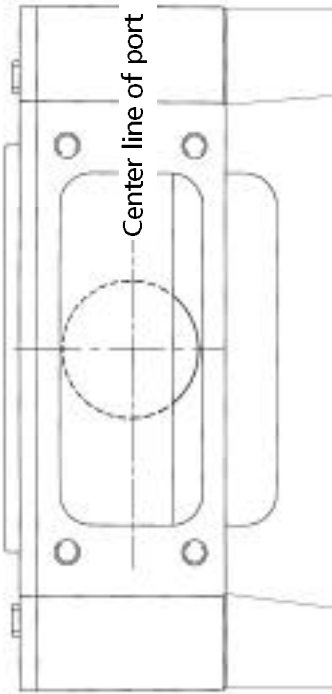

Fig 2

For dimensions of the hopper inlet see overleaf.



Hy-Line and Ultima Lobe Pumps

2/00

6.70

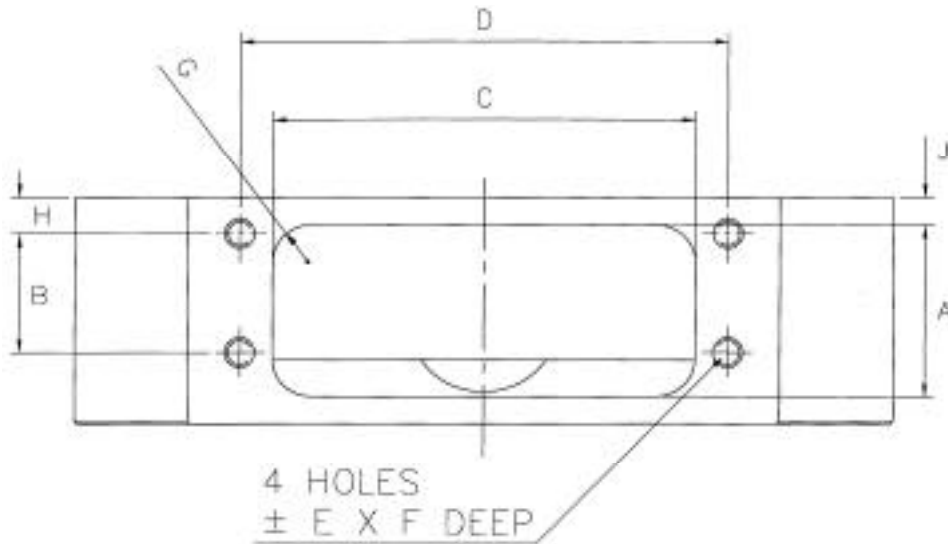

Hopper port dimensions

(dimensions in millimeters)										Cross sectional Area	Equivalent circular bore Dia	
Model	A	B	C	D	E	F	G	H	J			
	mm	mm	mm	mm	mm	mm	mm	mm	mm	mm	mm	mm
LH42	24	24	70	82	M8 x 1.25	12	12	5	5	1680	46.2	
LH44	40	40	70	82	M8 x 1.25	12	13	5	5	2800	59.7	
LH52	38	38	80	92	M8 x 1.25	12	13	6	6	3040	62.2	
LH54	66	66	80	92	M8 x 1.25	12	13	6	6	5280	82.0	
LH62	58	40	138	164	M10 x 1.5	12	13	12	9	5520	83.8	
LH64	87	66	142	164	M10 x 1.5	12	13	12	9	9372	109.2	

(dimensions in inches with metric threads in millimeters)										Cross sectional Area	Equivalent circular bore Dia	
Model	A	B	C	D	E	F	G	H	J			
	inches	inches	inches	inches	mm	inches	inches	inches	inches	inches	inches	inches
LH42	0.94	0.94	2.76	3.23	M8 x 1.25	0.5	0.47	0.20	0.20	2.60	1.82	
LH44	1.57	1.57	2.76	3.23	M8 x 1.25	0.5	0.51	0.20	0.20	4.34	2.35	
LH52	1.50	1.50	3.15	3.62	M8 x 1.25	0.5	0.51	0.24	0.24	4.71	2.45	
LH54	2.60	2.60	3.15	3.62	M8 x 1.25	0.5	0.51	0.24	0.24	8.18	3.23	
LH62	2.28	1.57	5.43	6.46	M10 x 1.5	0.5	0.51	0.47	0.35	8.56	3.30	
LH64	3.43	2.60	5.59	6.46	M10 x 1.5	0.5	0.51	0.47	0.35	14.53	4.30	

 	USA Jabsco 20 Icon Foothill Ranch CA 92610-3000 Tel : +1 949 609 5106 Fax : +1 949 859 1254	UK Jabsco Bingley Road Hoddesdon Hertfordshire, EN11 0BU Tel : +44 (0) 1992 450 145 Fax : +44 (0) 1992 467 132	GERMANY Jabsco GmbH Oststrasse 28 22844 Norderstedt Tel : +49 (0) 40 53 53 73 0 Fax : +49 (0) 40 53 53 73 11
------	---	--	---

Warranty: All products of the company are sold and all services of the company are offered subject to the company's warranty and terms and conditions of sale, copies of which will be furnished upon request. The information provided herein is for guidance only, it does not constitute a guarantee of the performance or specification of any individual product or component.

Temperature-Control Jackets

Pumps are available with 3 different types of Temperature Control Jackets. These allow hot water or steam to be piped to the pump to maintain product temperature in the pump or to heat the pump prior to starting. This is used to:

- Prevent product from degrading, separating or crystallizing due to cooling in the pump
- Protect the pump from the risk of starting up full of solidified product
- Maintain product viscosity in the process to avoid excessive pressures

Alternatively, cold liquid can be piped through the jacket to counteract heating of product within the pump. This is particularly useful for:

- Steam or hot water aseptic barrier applications where the barrier fluid will add heat to the process
- Continuous re-circulation applications where the pumping action adds pressure energy to the liquid every time it passes through the pump

Types of Jacket :-

End Cover Jacket :-

Use for non critical products

Pump Head Jackets :-

Use for products where good temperature control is required

Rotor Case Side Jackets :-

Use where product requires superior temperature control

End Cover Jacket

The jacket is manufactured from 316 grade stainless steel. It is fitted to the centre of the end cover and offers a low cost option for a moderate control of the pump head temperature. It can be used for products that are of a non-critical nature: i.e. have a wide temperature control band. The jacket does not give good penetration to the shaft seals, this can be accomplished by utilizing a flushed seal with a suitable temperature controlled flushing media. Alternatively Pump Head Jackets can be utilized. The jacket liquid never comes into contact with the pumped product. So there is no risk of contamination.

Application limits are:

Jacket Pressure: 2 bar (30 psi).
Temperature: 130°C (265°F).

Pump Sizes:	42 & 44	52 & 54	62 & 64
A	56.0/62.0	62.0/70.5	76.0/96.5
B	32.0mm	37.0mm	57.0mm
Connection Size -C	1/4" BSP	1/4" BSP	1/4" BSP

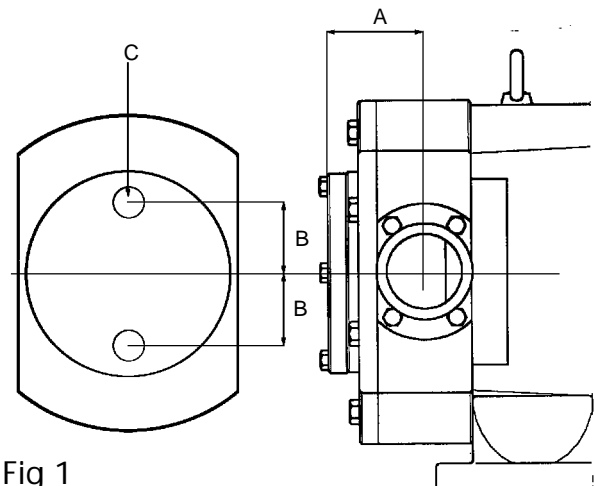

Fig 1

Pump Head Jackets

These are fitted to the top and bottom of the end cover and sealed with Viton O-rings. They give good temperature control of the entire pump head. Temperature penetration is superior to conventional 'saddles' mounted on the top and the bottom of the rotor case because the temperature is absorbed directly into the rotor case and NOT into the bearing housing (bearing frame). This type of temperature control device can be used for products which require moderately tight control of temperature band. The shaft seal is also temperature controlled to a moderate degree. However, if superior temperature control is required then Rotor Case Side Jackets should be utilized.

The design of the Pump Head Jacket allows installation with an integral pump head relief valve.



Hy-Line and Ultima Lobe Pumps

4/00

6.78

Material of Jacket 316 Stainless Steel
 Material of O-rings Viton
 Temperature 130°C (265°F)
 Pressure 2 bar (30psi)

Application limits are:

Jacket Pressure: 2 bar (30 psi).
 Temperature: 130°C (265°F).

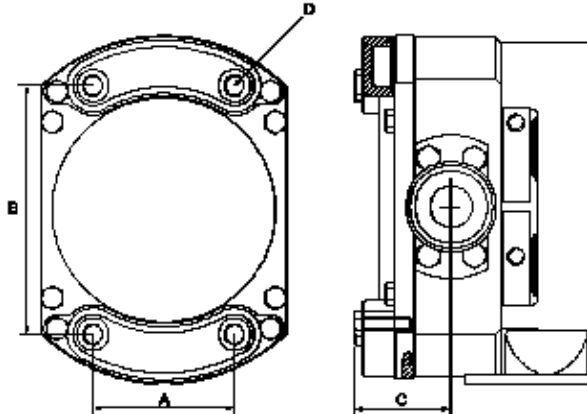

Dimensions in millimeters

Pump Size:	42	44	52	54	62	64
A	25	30	30	29	Not Available	33
B	51	57	57	76.5		93
C	8.5	16	16	0		26
Connection Size D	3/8" BSP	3/8" BSP	3/8" BSP	1/2" BSP	1/2" BSP	1/2" BSP

Pump Size:	42	44	52	54	62	64
A	55	55	69	69	81	81
B	148	148	166.2	166.2	181.8	181.8
C	53	59	59	67.5	74.9	95.5
Connection Size D	1/4" BS21	1/4" BS21	1/4" BS21	1/4" BS21	1/4" BS21	1/4" BS21

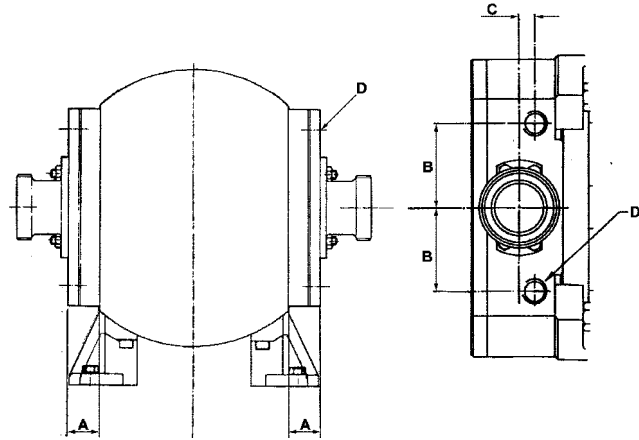

Rotor Case Side Jackets

These are clamped between the bolt on port and the rotor case (available on Hy-Line only). These jackets give exceptional temperature control of the entire pump head, including the seals. They are utilized where superior temperature control of the product is required. A second port joint ring is used to seal the jacket to the case.

These jackets cannot be fitted to pumps with flushed or double seals as they obstruct the flush connections.

Individual jacket kits contain one jacket, longer port bolts and a Nitrile port joint ring. If fitting jackets to a pump fitted with an elastomer other than Nitrile it is necessary to purchase the correct material port joint ring separately. Pumps can be fitted with either two jackets for maximum heating/cooling or only one, e.g. less demanding applications or rectangular inlet pumps.

Installation Procedure

Pumps fitted with any type of jacket should be installed such that air pockets are avoided. This is best achieved by a) individual feed to the lowest point of each jacket, b) feed to the lowest jacket or connection from which feed into the highest jacket should be applied.

Jabsco



ITT Industries

USA

Jabsco
 20 Icon
 Foothill Ranch
 CA 92610-3000

Tel : +1 949 609 5106
 Fax : +1 949 859 1254

UK

Jabsco
 Bingley Road
 Hoddesdon
 Hertfordshire, EN11 0BU

Tel : +44 (0) 1992 450 145
 Fax : +44 (0) 1992 467 132

GERMANY

Jabsco GmbH
 Oststrasse 28
 22844 Norderstedt

Tel : +49 (0) 40 53 53 73 0
 Fax : +49 (0) 40 53 53 73 11



Surface Finishes

Hy~Line and Ultima pumps are available with three alternative finishes for all fluid-contact surfaces i.e. rotors, internal surfaces of rotor case and end cover, port bores.

Finish	Surface Roughness	Approx grit equivalent	Ordering suffix code
Standard Machined	0.8 m Ra (32 microinch)	150	none
Electropolish	0.8 m Ra (32 microinch)	180	Y
Mechanical Polish	0.5 m Ra (20 microinch)	240	Z

Standard Finish

Product contact surfaces are machined to 0.8 micron Ra (32 micro inch). This conforms to the current requirements of US 3A Standard 02-09. This is accepted by many users as adequate for hygienic applications.

Electropolish Option

Some users, particularly in the pharmaceutical industries, specify electropolish and although the measurable change on surface roughness after electropolishing is small, the effects are:-

- a) Rounding and smoothing of surface imperfections - thus reducing the ability of product to adhere to the surface or be damaged by the sharp protrusions on the surface.
- b) Cleaning and passivating the surface - improves corrosion resistance and prevents the release of surface impurities into the product.

Components having product-contact surfaces are electropolished all over and therefore give improved external cleanability.

Mechanical Polish Option

Users requiring the very highest standards of purity can specify mechanical polishing. All product contact surfaces are polished to a surface finish of 0.5 microns Ra, (equivalent to 20 microinches Ra and approximating to 240 grit finish) and then electropolished. The advantages of this are:-

- a) Improved cleanability. Due to the virtual elimination of crevices, even micro-biological particles cannot become trapped, i.e. "held up" on the surface during cleaning
- b) Less product damage. The removal of the small but sharp surface peaks left by machining operations reduces damage, particularly to cellular products

All product contact surfaces are polished with silicon carbide abrasive. The last grit utilized is 240 grit or finer and results in a surface roughness of 0.5 micron Ra. The polishing process is controlled to remove the minimum amount of material from the component surfaces consistent with achieving the above requirements. Surface contours are maintained and square corners are not rounded thus minimizing loss of pump performance. Following mechanical polishing, components are electropolished on all surfaces.

Users should be aware that, although polishing improves the flow through valves, pipes, etc. it reduces the output from a positive-displacement pump when pumping low-viscosity liquids. Polishing increases slippage so the pump needs to be run faster to compensate. This may be undesirable as it can result in greater shear stress and greater shear damage to the liquid. It is possible that the additional shear damage to delicate liquids resulting from the extra slippage can outweigh the benefits of polishing. Also, an unnecessarily large pump may be needed to compensate for the loss of output.



Hy-Line and Ultima Lobe Pumps

2/00

6.86

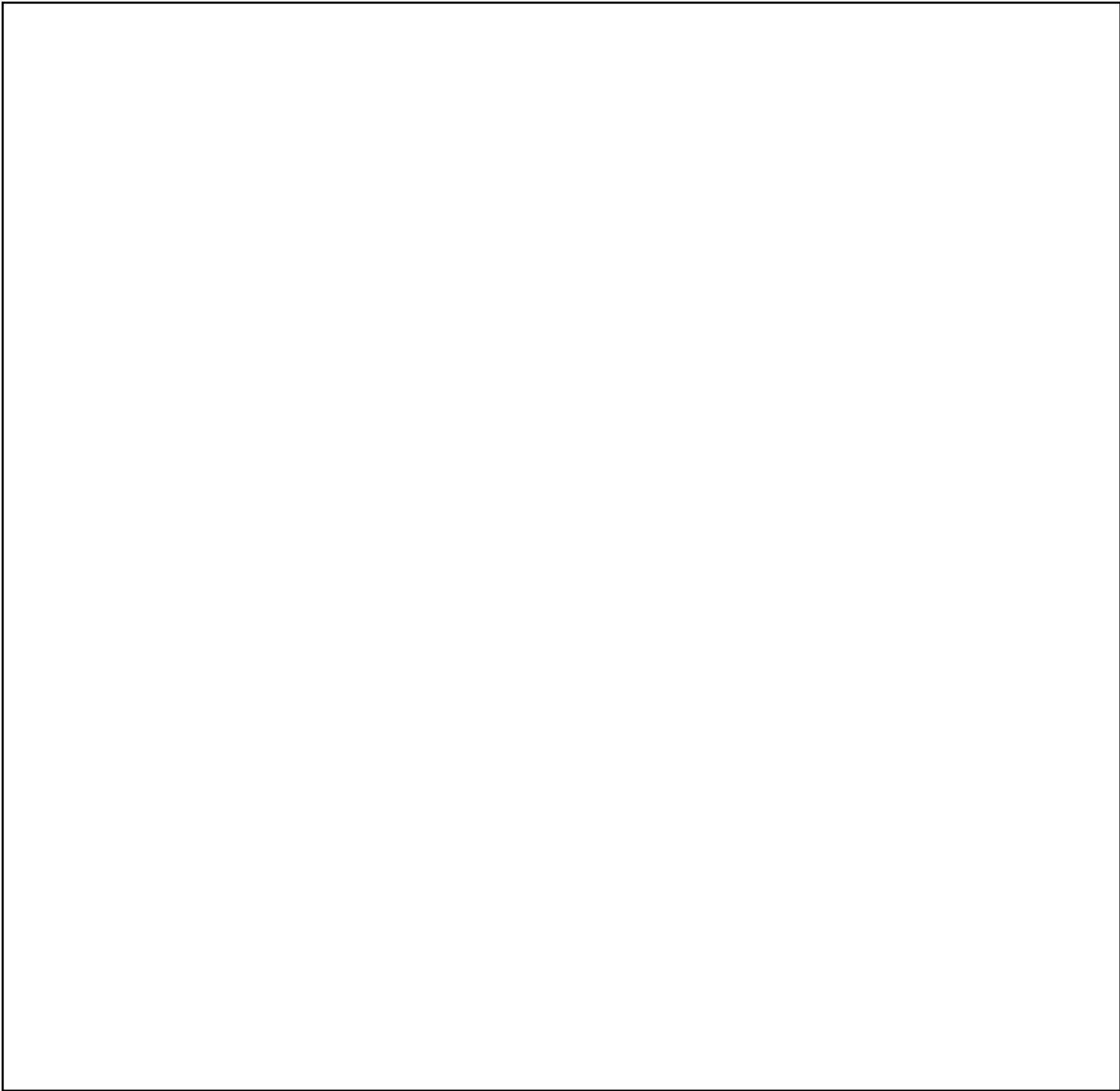

Jabsco



ITT Industries

USA

Jabsco
20 Icon
Foothill Ranch
CA 92610-3000

Tel : +1 949 609 5106
Fax : +1 949 859 1254

UK

Jabsco
Bingley Road
Hoddesdon
Hertfordshire, EN11 0BU

Tel : +44 (0) 1992 450 145
Fax : +44 (0) 1992 467 132

GERMANY

Jabsco GmbH
Oststrasse 28
22844 Norderstedt

Tel : +49 (0) 40 53 53 73 0
Fax : +49 (0) 40 53 53 73 11



Cleaning In Place (CIP) And Manual Cleaning (Strip Clean)

Cleaning of process equipment

In many applications not only in the hygienic industries (food, pharmaceutical etc) but also in chemical and industrial duties, fast and effective cleaning is important. Living contaminants such as bacteria and other organisms must not be introduced or allowed to multiply and all traces of fluid must be removed at the end of a batch, process or at product changeover to prevent any intermixing. To understand the features and benefits of the Hy~Line and Ultima pumps it is important to understand why and how equipment is cleaned.

How Clean Is Clean ?

In order to clean a pump or other piece of 'closed' equipment, it must either be dismantled (manual cleaning), or cleaned in place (CIP) as part of the procedure for cleaning the entire process. The higher the standard required, the more sophisticated the cleaning process. The standard (level) of cleaning required depends on the needs of the process. There are four generally recognized levels:

User's requirement	Level of cleaning	Pump
To prevent intermixing of, for example, paints, dyes, inert chemicals at product change-over	Visually clean. Manual cleaning or simple CIP	Hy~Line
Food processes for ingredients, pre-pasteurization, stable foods and short storage life	Hygienic, with small but acceptable levels of bacteria remaining. Rigorous manual cleaning, or ordinary CIP	Hy~Line
After pasteurization, medicines, unstable and long shelf-life foods, multi-product chemicals facilities	Semi (pseudo) sterile. No or almost no micro-organisms remaining in the pump. Can only be achieved with CIP	Hy~Line or Ultima
Sterile pharmaceuticals manufacture, bio-technology	Truly sterile. Absolutely no living organisms remaining in the pump, guaranteed every time. CIP followed by SIP (sterilize in place with steam)	Ultima

Cleaning Systems

The type of cleaning system used depends partly on the level of cleaning required but also on what is to be removed. Cleaning, whether mechanical or CIP, depends on a combination of:

Chemical reaction	Detergents, acid, alkalis
Scouring action	Turbulent flow, scrubbing
Heat	Hot water
Time	Residence time for cleaning liquids in contact

Organic materials such as oils, fats, proteins need a different system to inorganic materials such as mineral salts. Detergent manufacturers can give advice on the correct use of chemicals and temperature. CIP usually needs a velocity of 1.5 m/sec (5 ft/sec) through the pipeline to achieve the turbulent flow required

Choice Of Cleaning Processes

Manual cleaning has the advantage that no special pipework and CIP equipment (tank, heater etc) are needed. But CIP is becoming much more common as there are many advantages of CIP over manual cleaning.



Hy~Line and Ultima Lobe Pumps

2/00

6.94

Benefit of CIP	Value to the user
CIP is faster by up to 75% so saves time	Process equipment is available for production for more hours (up-time) when it is earning profits not standing idle
CIP can be controlled automatically	Less labor costs - people can carry out other more productive work
CIP achieves a much higher standard of cleaning if suitable pumps are installed	Equipment is cleaner and is more consistently clean. This gives much higher confidence in the process and reduces risk of product contamination. It is essential for very high levels of cleaning but only some pumps can be CIP cleaned to an acceptable standard
Pump does not need to be stripped down to be CIP cleaned	No risk of damage to parts during cleaning so less cost of spares, no chance of incorrect re-assembly so pump will always work correctly when process is re-started
Easy access to the pump is less important	Pump can be positioned anywhere, allowing more efficient use of space, shorter pipe runs and a safer working environment
High temperatures and aggressive chemicals can be used	No danger of injury to operators

Design

Most pumps with internally-contacting parts or with internal bearings can not generally be cleaned in place to the standards demanded by the contaminant-sensitive industries. This includes most gear pumps, sliding-vane pumps etc. Also manufacturers of many older designs of lobe pumps claim that their products can be CIP cleaned but this may be only partly true, depending on the pump design and on the level of cleaning required by the customer.

Hy~Line lobe pumps from Jabsco are designed to be either manually or CIP cleaned to a high standard. (For more details on these features, refer to appropriate data sheets)

Crevice free shaft seals: Hy~Line and Ultima pumps both use essentially the same shaft seals,

which not only provide a bacteria-tight joint but also meet the highest CIP requirements. In most rotary lobe pumps the fluid contacts the inside diameter of the shaft seals, an area from which it can be very difficult to clean out product and contaminants. In the Hy~Line/Ultima seal, fluid only contacts the outside diameter of the seal.

Self-Draining Features: By careful attention to the shape of not only the rotor bores but also the shaft seals, Hy~Line and Ultima pumps can be drained of fluid prior to cleaning. Also, they can be completely emptied of CIP fluid prior to restarting the process by mounting the pump with the inlet and outlet pipes vertical.

Surface Finish: Hy~Line and Ultima lobe pumps are manufactured to a high standard of internal smoothness, 0.8 μ Ra (32 micro-inches). Optional electropolishing cleans and smoothens the surfaces without reducing efficiency and a further option of mechanical polishing to a surface finish down to 0.5 μ Ra (20 micro inches). can be specified.

External Standards: Hy~Line pumps are designed to the US 3A Sanitary Standards for Centrifugal and Positive Rotary Pumps for Milk and Milk Products, 02-09 as well as many customers' own internal standards for hygienic equipment. These standards specify design, dimensional, construction and material requirements.

Ultima pumps have additional features making CIP even faster and more effective, allowing the very highest standards of CIP to be achieved:

External rotor retainers: by holding the rotors onto their shafts outside the pump chamber any areas where pumped fluid can collect around bolts and recesses can be totally eliminated,

Gasket Type Joints: the Ultima design completely eliminates O-ring joints from the fluid-contact areas including the shaft seals and the end-cover joint.

External Standards: Hygiene Testing: The Ultima line of pumps is developed from the Jabsco 55 Series pump, which passed the only internationally recognized tests designed to prove the hygienic standards of pumps and similar equipment. The Ultima pump and some versions of the Hy~Line pump have also passed this test. These tests were carried out by Campden and Choreleywood Food Research Association, to the test protocols developed by the European Hygienic Equipment Design Group (EHEDG). An independent association, with



members drawn from users and manufacturers of equipment as well as from research associations, the EHEDG was established to influence standards of design and testing of hygienic equipment to ensure foods and similar products are processed hygienically and safely. Their tests involve deliberate contamination of the product and then an evaluation of the effectiveness of the cleaning, sterilizing and sealing by bacteriological methods.

The EHEDG clean-in-place protocol compares the cleanliness of the pump to the cleanliness of a piece of reference pipe connected to the pump and subjected to the same test procedure. The system is soiled under pressure with a soured milk solution containing spores of a bacterium strain. The assembly is subjected to a light clean-in-place routine, drained and then the inner surfaces are covered with a molten agar. After incubation, the degree of discoloration of agar (resulting from residual bacteria after cleaning) is compared to that from the reference pipe. All components must show no greater discoloration than the reference pipe for the pump to pass the test, proving that there are no crevices in which product and hence bacteria could accumulate. The pumps easily passed this test. Copies of the CCFRA certificate number FH/REP/36539/1 and test report are available on request.

Procedures For Cleaning In Place

Each pump is supplied in a generally clean condition but it is the responsibility of the user to establish suitable cleaning and sterilizing regimes appropriate to the fluid and process. These should be implemented before the pump is first used and as often as require thereafter. The following guidelines will help with effective cleaning of both Hy~Line and Ultima pumps and minimize risk of damage to the pump.

1. Rinse through system with a suitable liquid, usually water at approximately 50°C (120°F), as soon as possible after completion of process to remove bulk of residues before they dry onto surfaces.

2. If CIP will not be carried out immediately after rinsing, leave pump and system full of rinse liquid.
3. Choose chemical cleaning agents to suit the nature of the contamination to be removed and use them in accordance with manufacturer's recommended dilution, temperature and circulation time but do not exceed 90°C (195°F). Confirm compatibility with pump materials of construction.
4. CIP fluid flow should result in a mean pipeline velocity of at least 1.5 m/sec. (5 ft/sec).

If using the lobe pump to circulate the CIP fluid, refer to the Performance Data Sheet for pump speed to give required flow, taking account of pressure losses through pipework. Note that all pumps are more susceptible to cavitation when pumping hot liquids. Ensure adequate Net Inlet Pressure available. If using a separate pump to circulate CIP fluids, the lobe pump may need to be rotated at a speed sufficiently high to allow the fluid to pass freely through. If sufficient pipe velocity cannot be achieved, fit a by-pass loop to divert excess flow past pump.

CIP fluid pressures must equal or exceed process pressure at all points in the system to ensure fluid reaches all contact surfaces. It may be necessary to restrict flow in discharge pipework to achieve this but do not exceed differential pressure and temperatures shown on pump Performance Data Sheet. A minimum differential pressure of 1 bar is recommended for effective cleaning.

5. After CIP, rinse through with neutralizers and clean water to remove all traces of cleaning agents.

Do not pass cold liquid through pump immediately after hot - allow temperature to change slowly. Failure to observe can result in pump seizure.



Hy~Line and Ultima Lobe Pumps

2/00

6.96

Procedure For Manual Cleaning

See Installation, Operating and Maintenance Manual for procedures to dismantle and re-assemble fluid contact parts. Ultima pumps are not intended to be manually cleaned - Instead specify a Hy~Line pump which is designed to be stripped more easily for cleaning.

Take care not to scratch or damage pump parts especially seal faces.

Do not use steel abrasive wool or brushes on fluid wetted surfaces as particles may become embedded in the surface and cause corrosion.

Use suitable cleaning agents in accordance with their manufacturer's instructions regarding temperatures, dilutions, skin contact precautions and other safety information. Thoroughly clean all fluid contact surfaces and rinse as required. As a minimum it will be necessary to remove the end cover and rotors and stationary seal faces. It should not be necessary to remove the seal rotating seats from the rotors during routine cleaning.

This information is provided for guidance only. It is the responsibility of the pump user to satisfy himself that the CIP protocol chosen is adequate to achieve the desired levels of cleanliness and Jabsco cannot accept any responsibility for contamination or loss of pumped fluids.

Jabsco



ITT Industries

USA

Jabsco
20 Icon
Foothill Ranch
CA 92610-3000

Tel : +1 949 609 5106
Fax : +1 949 859 1254

UK

Jabsco
Bingley Road
Hoddesdon
Hertfordshire, EN11 0BU

Tel : +44 (0) 1992 450 145
Fax : +44 (0) 1992 467 132

GERMANY

Jabsco GmbH
Oststrasse 28
22844 Norderstedt

Tel : +49 (0) 40 53 53 73 0
Fax : +49 (0) 40 53 53 73 11



Sterilizing In Place

In truly sterile processes, all product-contact components need to be sterilized. This is usually achieved by heating to high temperature (up to 140°C, 285°F) to kill organisms still remaining on the surface of the equipment. This can be achieved by physically dismantling the pump and autoclaving the parts, bagging, taking back to the pump and re-assembling; a long, costly process which causes problems to personnel and can result in accidental damage to components. But when using the either the Hy~Line or Ultima pumps it is possible to pass steam through the complete assembled system to sterilize the internal surfaces without dismantling the pump.

To achieve 100% sterility, it is important to steam through for a period long enough for the coldest part of the system to reach the correct temperature and hold for the time period required to kill off the organisms. The Hy~Line and Ultima pump heads are designed to completely self drain, ensuring all surfaces are exposed to steam and the component shape and choice of materials ensures thermal stability and temperature tolerance.

Procedure

If using chemical sanitizers, follow guidelines as for CIP above.

If using steam, pump specification must be chosen at time of selection noting:

EPDM elastomers offer best resistance to repeated steam contact but will need to be changed periodically. PTFE (Teflon) is least suitable for steam contact - PTFE end cover joints may need to be replaced every time the pump is sterilized. Pump should be mounted with the port axis vertical to avoid collecting liquid pools.

1. Thoroughly clean pump and process lines prior to sterilization.
2. If pump is fitted with sterile barriers (on seals, end cover) for the purpose of maintaining sterility, barrier fluid must be connected throughout SIP cycle to avoid re-infection.

3. Pass clean, wet steam through system until all component temperatures have stabilized. Steam must be free of scale, rust and particles - a filter may be necessary. Typically steam will be at 121°C (250°F) and 1 bar (15 psi). Soak time, to bring the pump up to temperature, is typically 20 minutes but this should be established, e.g. using thermocouples, as the required soak time will vary with individual installations. Do not rotate the lobe pump during this heating phase. Do not loosen or remove any pump components or pipe connections during steam sterilization as escaping steam may cause serious injury.

4. Continue to pass wet steam through the lobe pump and process lines during the hold time. Hold time will be determined by the user to achieve desired level sterility. Typically this will be between 20 and 60 minutes.

The lobe pump should not be rotated during this hold time unless absolutely essential to achieve sterility, due to increased risk of pump seizure. All pump components will normally reach desired temperature by thermal conduction without rotating the pump. If essential, the lobe pump can be rotated during hold time by hand - beware of danger of hot surfaces - or at a maximum of 50 rpm if the pump is fitted with either:

Single carbon/stainless steel or carbon/silicon carbide seals (Code 8 or 3).

Flushed or double seals (codes 1, 4, 5 or 7) provided a liquid flush, e.g. condensate, is connected and operating at a pressure above the steam pressure within the pump during SIP. If the lobe pump is fitted with single silicon carbide/ silicon carbide seals (Code 2) it must not be rotated during hold time as the seal faces can bind together.

5. At the end of hold time, pump must be allowed to cool naturally or can be purged with sterile air/ inert gas. Pump must not be rotated during cooling.
6. Do not allow cool liquid to enter the lobe pump before pump temperature has fallen to 60°C (140°F) or lower.

If the pump is fitted with single silicon carbide/ silicon carbide seals (Code 2), flood it with liquid to lubricate the seals before rotating it.



Hy-Line and Ultima Lobe Pumps

2/00

6.102



Jabsco



ITT Industries

USA

Jabsco
20 Icon
Foothill Ranch
CA 92610-3000

Tel : +1 949 609 5106
Fax : +1 949 859 1254

UK

Jabsco
Bingley Road
Hoddesdon
Hertfordshire, EN11 0BU

Tel : +44 (0) 1992 450 145
Fax : +44 (0) 1992 467 132

GERMANY

Jabsco GmbH
Oststrasse 28
22844 Norderstedt

Tel : +49 (0) 40 53 53 73 0
Fax : +49 (0) 40 53 53 73 11



Aseptic Operation

An aseptic process is one in which all unwanted micro-organisms are kept out of the fluid stream. This prevents spoiling of sensitive products and ensures that only the intended reactions take place in the process. In the Ultima design, high specification joints are used instead of O-rings ensuring that microbial contaminants cannot enter the product zone. Once the system has been cleaned and sterilized it will remain clean and sterile.

For increased security, secondary joints can be fitted to all potential entry points of both Hy~Line and Ultima pumps to allow steam or sterile fluid barriers to be connected. Also, a pump which is externally dirty on the outside will harbor colonies of bacteria which are more likely to infect the internal surfaces of the pump. All Hy~Line and Ultima pumps are designed to be easy to clean externally and are therefore less likely to cause product contamination.



Hy-Line and Ultima Lobe Pumps

2/00

6.110

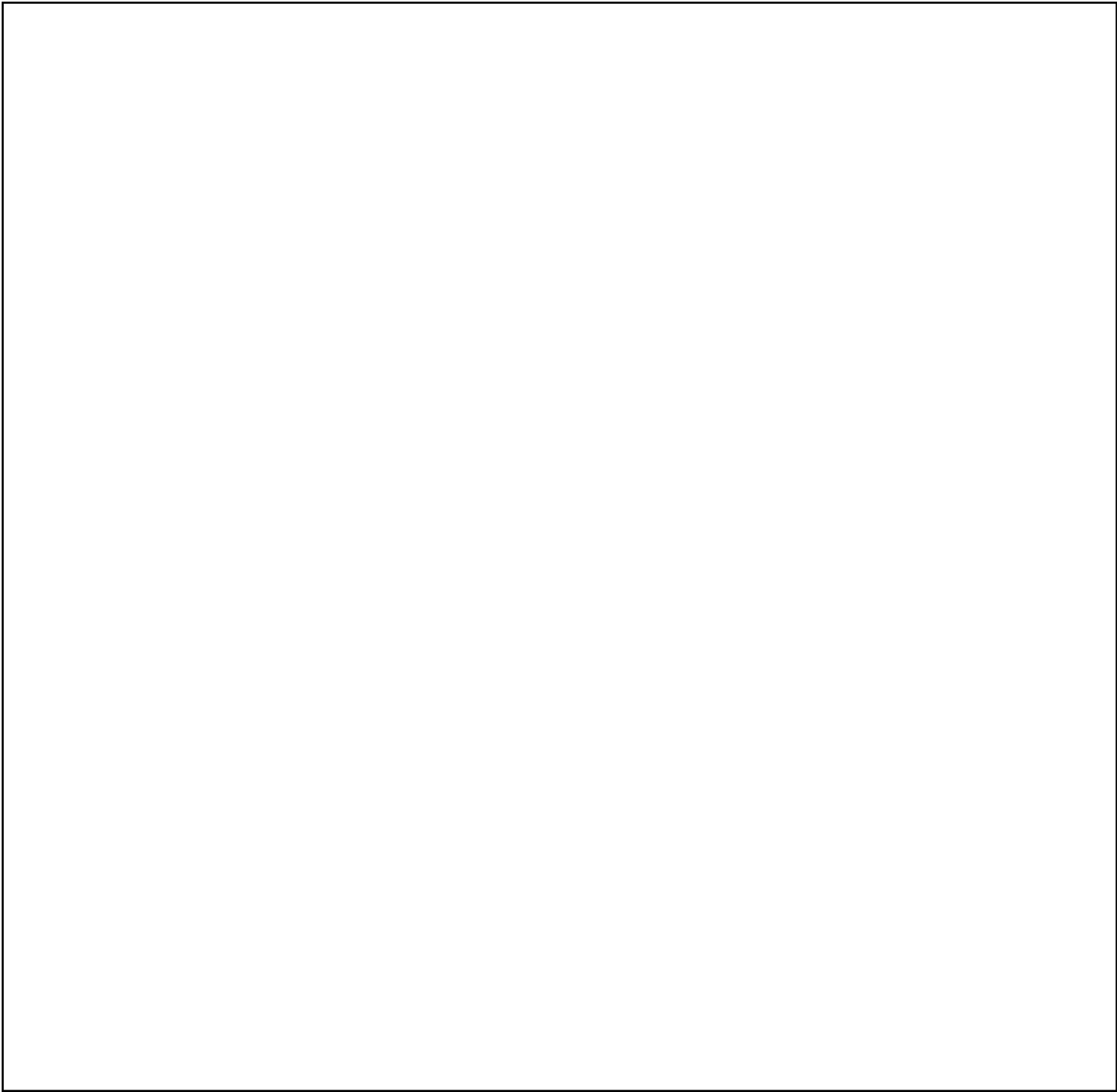

Jabsco



ITT Industries

USA

Jabsco
20 Icon
Foothill Ranch
CA 92610-3000

Tel : +1 949 609 5106
Fax : +1 949 859 1254

UK

Jabsco
Bingley Road
Hoddesdon
Hertfordshire, EN11 0BU

Tel : +44 (0) 1992 450 145
Fax : +44 (0) 1992 467 132

GERMANY

Jabsco GmbH
Oststrasse 28
22844 Norderstedt

Tel : +49 (0) 40 53 53 73 0
Fax : +49 (0) 40 53 53 73 11