

SANITARY PUMP

FEATURES

- Body:** Type 316 Stainless Steel
- Impeller:** Jabsco Sanitary Neoprene Compound
- Seal:** Sanitary Mechanical
- Bearings:** Ball/Roller Bearings
- Shaft:** Type 316 Stainless Steel
- Ports:** 2-1/2" Acme Threads
- Weight:** 53 lb (24 kg) approx.



Model 23930-5115

MODEL	DESCRIPTION
23930-5115	Standard Pressure Impeller ACME Ports

APPLICATION

This product is specifically designed for farm pick-up milk tanker trucks. Jabsco pumps are also available as pedestal mounted or close-coupled units with capacities to 100 GPM for other sanitary applications. Contact factory for details.

OPERATING INSTRUCTIONS

1. **INSTALLATION** – Pump may be mounted in any position. The rotation of the pump shaft determines the location of the pump's intake and discharge ports. Refer to dimensional drawing. Pump is normally assembled at factory for clockwise rotation looking at end cover. If counterclockwise rotation is desired, follow steps 1 and 2 of disassembly and step 9 of assembly instructions to change direction of impeller blade deflection under cam.
2. **DRIVE** – Belt or direct with flexible coupling. Belt Drive: Overtight belt load will reduce pump bearing life. Direct Drive: Clearance should be left between drive shaft and pump shaft when installing coupling. Always mount and align pump and drive shaft before tightening the coupling set screw. If pulley or coupling must be pressed on shaft, remove end cover and impeller to support shaft from impeller end during press operation. Do not hammer pulley or coupling on shaft; this may damage bearing or seal. Capacitor start motor is required to overcome starting torque of impeller.
3. **SPEEDS** – 100 RPM to the maximum shown in the performance curves. For longer pump life, operate at lowest possible speeds. Lower speeds are required for viscous liquids, consult the factory for proper speeds and horsepower requirements.
4. **SELF-PRIMING** – Primes at low or high speeds. For vertical dry suction lift of 10 feet, a minimum of 800 RPM is required. Pump will produce suction lift up to 22 feet when wet. **BE SURE SUCTION LINES ARE AIRTIGHT OR PUMP WILL NOT SELF-PRIME.**
5. **DISCHARGE** - When transferring liquids further than 25 feet, use 3" discharge line.
6. **RUNNING DRY** – Unit depends on liquid pumped for lubrication. **DO NOT RUN DRY** for more than 30 seconds. Lack of liquid will damage the impeller.
7. **PUMPAGE COMPATIBILITY** – When corrosive cleaning fluids are handled, pump life will be prolonged if pump is flushed with a neutralizing solution after each use or after each work day. A Tungsten Carbide Seal variation is available for pumping liquids that contain abrasives or are highly corrosive.
8. **PRESSURES** – Consult Performance Curves for maximum recommended pressures for pump in continuous operation. If pressures exceed those shown, consult the factory.

⚠ WARNING



Injury hazard. Exposed pulleys and belts can cause injury. Install shield around pulleys and belts. Stay clear while machinery is operating.

9. TEMPERATURES – The operating temperature limits of the pump: 45° to 150° F (7° to 65° C).
10. CLEANING – Before using pump, it should be disassembled and cleaned to remove any dust and dirt resulting from storage or shipping. Wash parts in standard cleaning solutions approved for handling stainless steel. Thoroughly rinse before reassembly. DO NOT USE IODINE BASED SANITIZERS as the iodine attacks the elastomer materials used in the impeller. All parts have been expertly machined and polished. HANDLE WITH CARE. DO NOT DROP OR MISHANDLE.
11. IMPELLER TORQUE – The torque required to initiate rotation of a new impeller in a dry pump body is:
 Forward = 14.8 pounds force – feet
 Reverse = 43.7 pounds force – feet
 These values may vary slightly due to manufacturing tolerances. Consult factory for more information.
12. SPARE PARTS – To avoid costly shutdowns, keep a spare JABSCO impeller, seal and O-ring set on hand.

MANUAL BY-PASS CIP ENDCOVER FOR JABSCO PUMPS

Jabsco stainless-steel milk collection tanker pumps are easily cleaned in place at the same time that the tanker is cleaned. This can be achieved in 2 ways:

By running the pump to circulate the cleaning liquid through the pipework and metering equipment; a separate land-based CIP pump may be used to provide the pressure to the tank spray balls. The pump and impeller can withstand hot water and proprietary chemicals for the duration of the cleaning cycle.

Alternatively, if the pump is fitted with the Jabsco Manual By-pass CIP Endcover Assembly the complete system can be cleaned with the milk collection pump static. This brings several advantages:

- **No Need to run the Vehicle Engine:** The hydraulic system is not required during cleaning so no engine fumes are generated in the CIP bay, noise is much reduced and unnecessary fuel consumption is eliminated.
- **More Effective Cleaning:** Tests have shown that cleaning is more thorough with the Manual By-pass End cover fitted.
- **Extended Pump Life:** During the cleaning cycle the pump is at greatest risk of running dry. If the cleaning fluid runs out e.g. during change-over from CIP fluid to rinse water, the pump impeller can be damaged if the pump is running. By cleaning the pump static, impeller life will be extended.

This end cover assembly fits in place of the standard pump end cover and contains a piston which moves back under the pressure from the separate CIP cleaning pump allowing cleaning fluid to by-pass the ends of the impeller.

CLEANING

Before starting the CIP pump, the center screw (24) of the manual by-pass assembly is loosened at least 10 turns counter-clockwise. This allows the piston (22) to travel back under the pressure of the CIP liquid. The system can then be cleaned using the regime established by the tanker operator; the pump does not need to be run or attended to in any way during cleaning. After cleaning, the center screw is tightened clockwise ready for normal pumping.

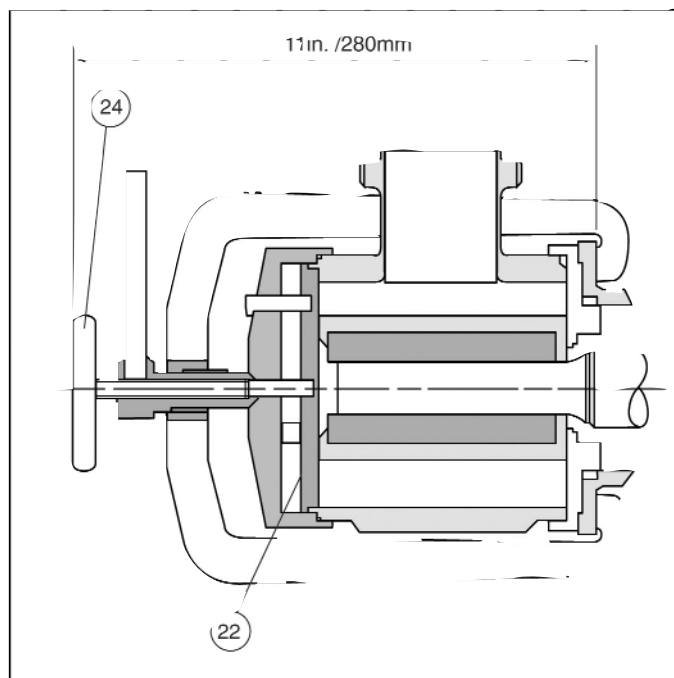
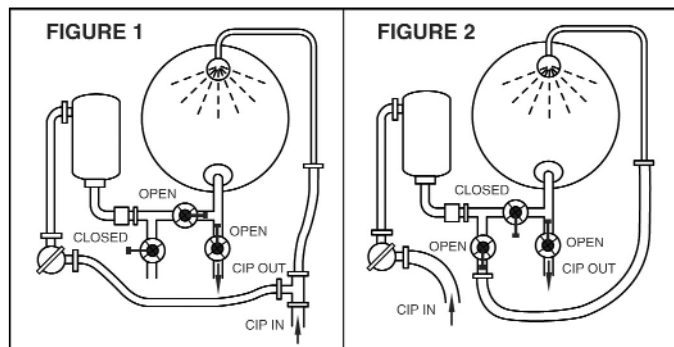

PIPEWORK

The pipework can be arranged in two ways during cleaning:

1. Parallel piping: the flow from the CIP pump is split at a tee-piece so part of the flow is taken direct to the tanker spray balls while the rest flows through the pump and the metering equipment. See fig 1.
2. Series piping: all the CIP flow is directed through the pump and metering equipment and then on to spray balls. See fig 2.

DIMENSIONAL DRAWINGS

INCHES (Millimetres)

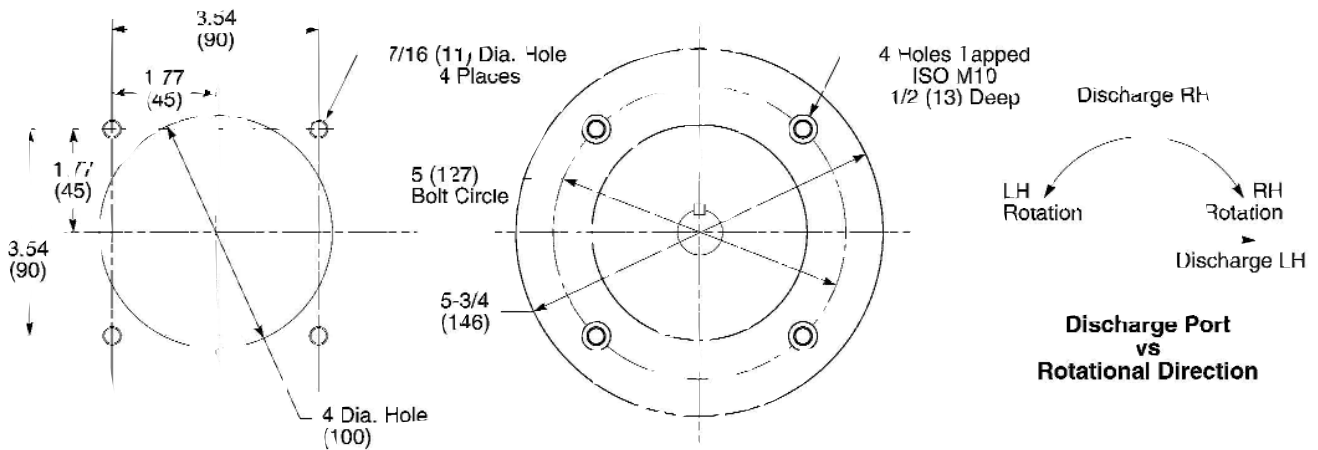
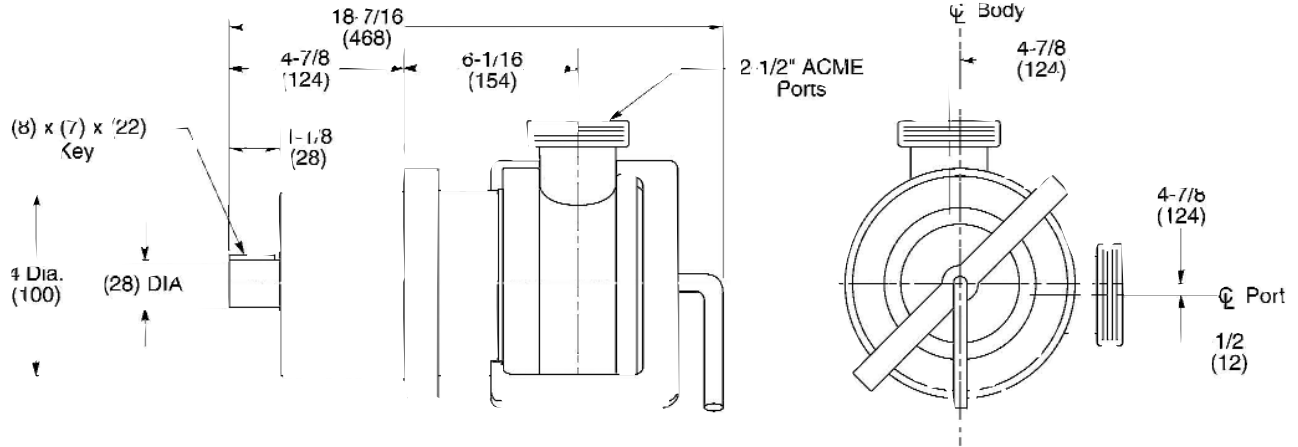

Mounting Hole Pattern

PERFORMANCE CURVES

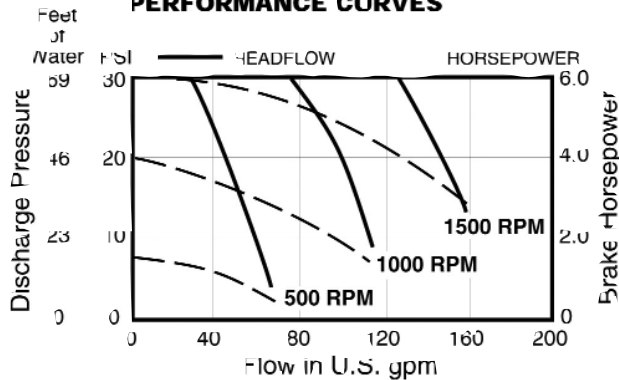

NOTE: Curves show approx HEAD-FLOW for new pump with neoprene impeller pumping water.

SUCTION HOSE LENGTH LIMIT 700 SIZE

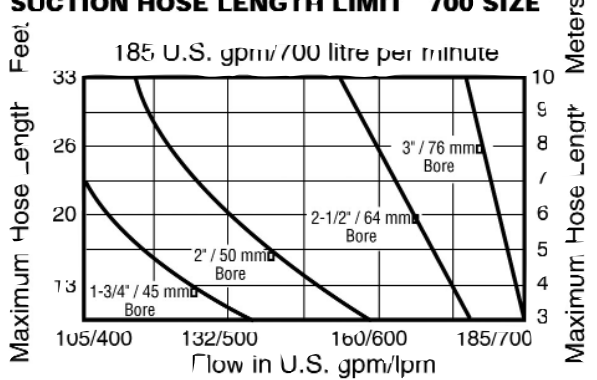

THESE GRAPHS ARE BASED ON: 2 inch (50 mm) diameter farm tank outlet. One elbow between suction hose and pump inlet. Farm tank milk level 0.5 ft below pump level on vehicle.

Jabsco



ITT Industries

Jabsco, 20 Icon, Foothill Ranch, CA 92610

Tel : + 1 949 609 5106

Fax : +1 949 859 1153

USA

Jabsco, Bingley Road, Hoddesdon, Hertfordshire, EN11 0BU

Tel : +44 (0) 1992 450 145

Fax : +44 (0) 1992 467 132

UK

Fluid Products Canada, 55 Royal Road, Guelph, Ontario N1H 1T1

Tel : +1 519 821 1900

Fax : +1 519 821 5316

CANADA

NHK Jabsco Co Ltd, 3-21-10, Shin - Yokohama, Kohoku-ku, Yokohama 222

Tel : +81 (0) 45 475 8906

Fax : +81 (0) 45 475 8908

JAPAN

Jabsco GmbH, Oststraße 28, 22844 Norderstedt

Tel : +49 (0) 40 53 53 73 0

Fax : +49 (0) 40 53 53 73 11

GERMANY

Warranty: All products of the company are sold and all services of the company are offered subject to the company's warranty and terms and conditions of sale, copies of which will be furnished upon request. The information provided herein is for guidance only, it does not constitute a guarantee of the performance or specification of any individual product or component.

©Copyright 2002 ITT Industries

43000-0674 Rev: 02/03