

Model		MX-F403	
Mark	CFV	RFV	KKV
1	Front casing	CFRETFE	
2	Impeller	CFRETFE	
3	Rear casing	CFRETFE	
4	Magnet capsule	CFRETFE	
5	O-ring	FKM*	
6	Spindle	High Purity Alumina Ceramic	SiC
7	Bearing	Carbon	PTFE
8	Rear thrust	CFRETFE	CFRPFA
9	Mouth ring	PTFE	SiC
10	Thrust/Liner ring	High Purity Alumina Ceramic	SiC
11	Lock pin	CFRETFE	

\* EPDM and AFLAS® O-ring also available.

# MX-F403 3 HP

- Engineered to meet the most severe operating conditions.
- When fitted with a carbon bearing, the MX will allow for brief periods of dry running.
- The MX Series is the first resin magnet pump that uses a *Split Volute Pump Casing* that forms a vortex chamber.
- Self-radiating structure (patent pending) – Heat dispersion holes force the liquid to circulate around the spindle and bearing .

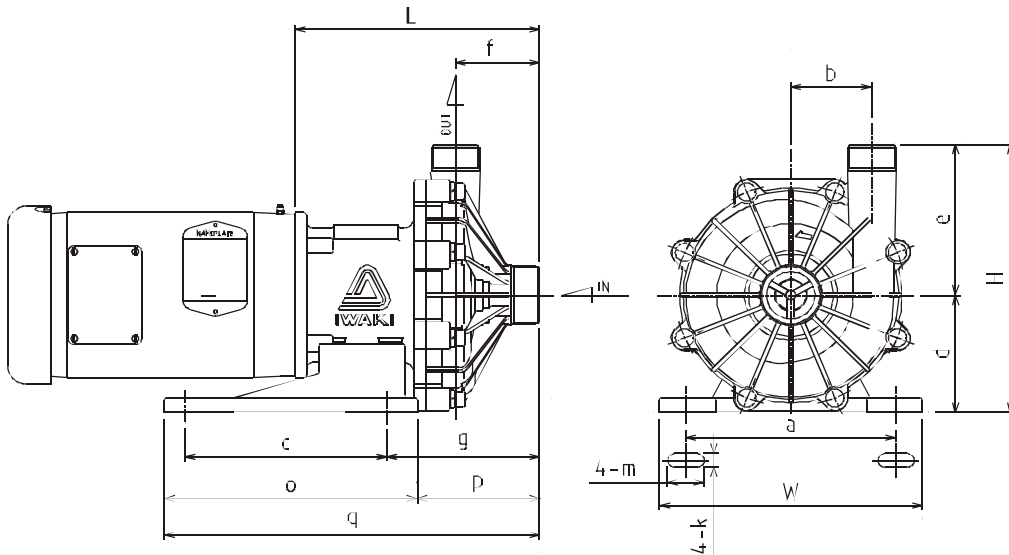

## Dimensions (in inches)

a	b	c	d	e	f	g	k	n	o	p	q	W	H	L
8.19	3.15	7.87	4.72	6.06	3.27	5.94	.47	1.42	9.84	4.76	14.61	10.24	10.78	9.53

## Specifications

Suction x Discharge	Maximum Discharge Pressure	Maximum Flow	Specific Gravity	Weight (less motor)
2" x 1.5"	88 ft.	130 gpm	1.2	32 lbs

