



***IWAKI AMERICA
MAGNETIC DRIVE PUMP
MX-70 & (F)100 SERIES***



Thank you for having selected an Iwaki America MX-70/100 Series magnetic drive pump. This instruction manual deals with the correct handling, maintenance, inspection and troubleshooting procedures for the MX magnetic drive pump. Please read through it carefully to ensure the optimum performance, safety and long service of your pump.

Contents

Item		Page
1	Unpacking and Inspection.....	1
2	Identification	1
3	Specifications	2
4	Handling.....	2
5	Installation and Operation.....	3
6	Assembly.....	4
7	Maintenance and Inspection.....	5
8	Parts Description and Exploded View	6
9	External Dimensions and Weight	7

This product is patent pending.

P/N 180243 Rev. A1 December 2003

1 UNPACKING AND INSPECTION

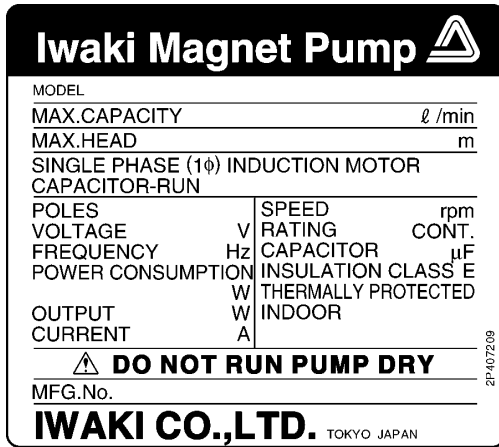

Open the package and check that the product conforms to your order. Also, check each of the following points. For any problem or inconsistency, contact your distributor at once.

1. Check that the model number indicated on the nameplate conforms to the specifications of your order.
2. Check that all the accessories you ordered are included.
3. Check that the pump body and parts have not been accidentally damaged or that any bolts have not been loosened in transit.

2 OPERATING PRINCIPLE

The centrifugal pump is driven by pair of magnets which are incorporated in the impeller and motor shaft. The sealless pump structure eliminates shaft seals such as conventional mechanical seals because the pump chamber is shielded by the casings and the impeller is operated by the magnets. The combined coupling torque of the drive magnet and impeller magnet gives sufficient driving power against the motor torque.

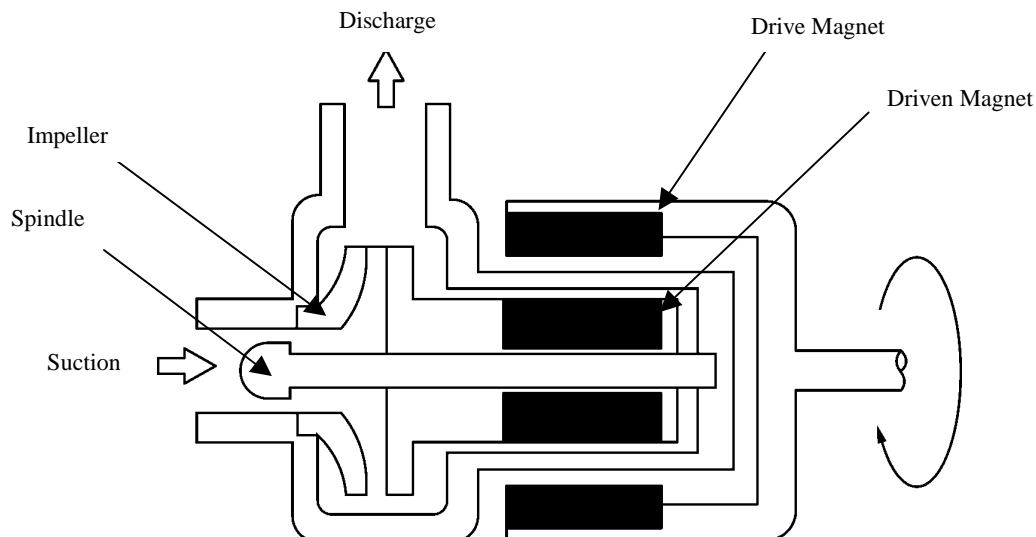

3 MODEL IDENTIFICATION GUIDE

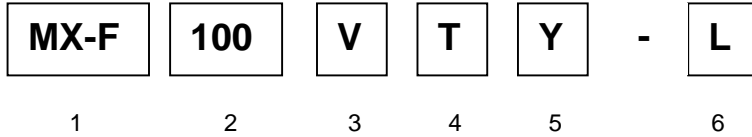

1. Series name

MX: GFRPP casing material
MX-F: CFRETFE casing material

2. Pump Size code

70: Not available for MX-F models
100: Available for MX and MX-F models

3. Wet end material

MX:	V:	FKM O-ring	E:	EPDM O-ring
MX-F:	RV:	PTFE bearing	KV:	SiC bearing
		FKM O-ring		FKM O-ring

4. Suction/Discharge Port Connections

Blank: Hose connection (available for MX (GFRPP) only)
T: Threaded connection

5. Impeller Code

MX: No code
MX-F: Y for 50/60 Hz
Z for 60 Hz only

6. Motor voltage code

Blank: 1 phase 100V
L: UL Listed

3 SPECIFICATIONS

Model	Suct x Disch	Specific Gravity Limit	Max. Discharge Pressure (ft)	BEP (Q-H)	Max Flow (GPM)	Motor output @50/60 Hz
MX-70	1" x 1"	1.0	26.2/36.1	13-25	23.8/26.4	150/180W
MX-100	1" x 1"	1.2	27.6/38.4	19-29	29/33	210/260W
MX-F100Y	1" x 1"	1.9/1.6	26.9/37.7	18-29	29/33	210/260W
MX-F100Z	1" x 1"	- /2.3	- / 26.9	16-20	- / 29	-/260W

Notes:

1. Fluid temperature range: 32-176°F (0-80°C)
2. Limit of specific gravity at maximum flow when fluid viscosity is 1CP. Fluids with specific gravities up to 2.3 can be handled with appropriate trimming of impeller. Consult factory for recommended trim.

Rated Current/Starting Current

Power Source Voltage	Rated Current (50/60Hz)		Starting Current (50/60 Hz)	
	MX-70	MX-(F)100	MX-70	MX(F)-100
110V (1 phase)	2.7A / 3.8A	4.0A / 4.0A	8.2A / 7.6A	8.8A /8.4A
220-240V (1 phase)	1.2A / 1.8A	1.58A / 1.83A	3.4A / 3.1A 3.6A / 3.3A	3.9A /3.7A 4.3A/ /3.9A

Sound Levels

Level of sound generated by the pump is shown in the table below.

Model	Sound Level (dB)*
MX-70	70
MX-(F)100	75

*Measured from a distance of 1m.

MX-70

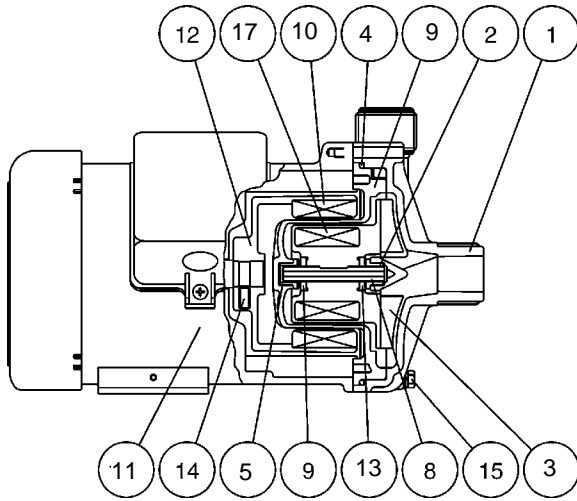

MX-(F)100

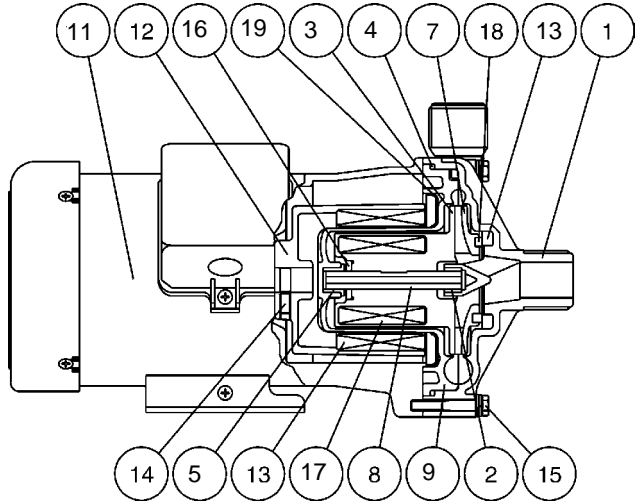

No.	Part	Qty	Material			
			MX-70	MX-100	MX-F100RV	MX-F100KV
1	Front casing	1	GFRPP		CFRETFE	
2	MX-70 Bearing	2	PPS	---	---	---
	MX-100 Bearing A	1	---	Fluoroplastic		SiC
3	Impeller	1	CFRPP		CFRETFE	
4	O-ring	1	FKM, EPDM		FKM	
5	MX-100 Bearing B	1	---	Fluoroplastic		SiC
7	Shroud	1	CFRPP		CFRETFE	
8	Spindle	1	Ceramic		High purity ceramic	SiC
9	Rear Casing	1	GFRPP		CFRETFE	
10	Drive magnet	1	Ferrite Magnet + Aluminum Alloy			
11	Motor	1				
12	Magnet housing	1	Cast Aluminum			
13	MX-70 thrust	2	Ceramic	---	---	---
	MX-100 front thrust	1	---	Ceramic	High purity ceramic-	--
14	Hex soc. head screw	2	Steel			
15	Hex head bolt	6	Stainless steel			
16	Impeller thrust*	1	---	Ceramic	High purity ceramic	SiC
17	Driven magnet	1				
18	Mouth ring	1	---	Fluoroplastics		---
19	Retainer/Backup ring	1	---	Stainless steel		

4 HANDLING INSTRUCTIONS

1. Do not operate the pump dry.

The sliding parts used in the MX-70/100 series pump are lubricated and cooled by the fluid being pumped. Never operate the pump dry or with the valves on the suction side closed. Otherwise, the inside of the pump will be damaged. If the pump is unavoidably or accidentally operated dry, with no obvious damage, allow the pump to cool down for a minimum of one hour before attempting to restart. Do not allow fluid to enter the pump cavity until the pump has cooled down. Sudden or rapid cooling of the pump may cause damage to the bearing system. A dry run operation device is recommended for the prevention of dry pump operation.

2. Starting

Prior to starting the pump, make sure that the power is turned off. Then carry out priming to fill the pump cavity with liquid.

Next, close the valves on the discharge side. Now you can turn the power on and start up the pump. When the pump has reached full speed and line pressure is stable, the discharge valves can be opened to the desired settings.

3. Stopping

When stopping the pump, first close the discharge valve gradually. When it is completely closed, turn off the power switch so that the pump stops. Never stop the pump suddenly by quickly closing a valve (i.e., solenoid or hydraulic valves).



Caution

Quick valve closure may cause water hammer which can cause severe damage to the pump.

4. Maximum system pressure rating is 31.0 PSI (2.2 kgf/cm²).

5. Influence of temperature.

The pump itself may not suffer a change in performance due to temperature fluctuation. However, the liquid may change in terms of viscosity, vapor pressure, and corrosive properties. Pay special attention to changes in liquid characteristics as a result of temperature fluctuation.

Liquid temperature range: 32 - 176°F (0-80°C)
Ambient temperature range: 32 - 104°F (0 - 40°C)

5 INSTALLATION AND OPERATION

■ Installation

1. Secure the pump to floor or platform by bolting down the motor using all holes provided.
2. Check power source for proper voltage and phase. Attach the pump to a switched, hardwired properly grounded circuit. Use appropriate wiring materials and abide by all local and national electrical codes.
3. Connect the inlet and outlet fittings of the pump with appropriate size tubing or pipe connections.
 - A. For tubing connections use standard hose clamps to secure tubing. ***DO NOT OVER TIGHTEN.***
 - B. For pipe thread connections, use pipe tape to insure a good seal. ***DO NOT OVER TIGHTEN.***
 - C. For convenient disconnection of pumps installed with rigid pipe, install unions near both inlet and outlet connections.

■ Operation

- A. If the pump is to be left idle for extended periods, flush the pump with water to prevent crystallization of the fluid inside the pump chamber.
- B. If the fluid to be pumped contains suspended solids, install a strainer in the suction plumbing, periodically inspect the suction strainer and remove any built-up debris.
- C. Fluids of high specific gravity CANNOT be pumped. See pump specifications for more information.
- D. The impeller may decouple from the drive magnet for several reasons: e.g. temperature, viscosity or specific gravity are too high. This is usually indicated by initial pumping, then a complete cut off of flow. Turn off power to the motor, allow it to stop rotating, then start it again. If the problem recurs, check for excess temperature, viscosity, or specific gravity.

6 ASSEMBLY

1. Place the motor on end vertically so that the shaft is pointed upward.
2. Install the drive magnet on the motor shaft and position the shaft flush with the inside of the magnet.
3. Insert the rear casing into the magnet/motor bracket.
4. Install the impeller and O-ring into the rear casing.
5. Place the front casing over the pump, making sure that the volute casing is aligned.
6. Using a hex head driver, fasten the liquid end to the bracket using six screws with flat and spring washers.

7 MAINTENANCE AND INSPECTION

■ Daily Inspection

1. Check that the pump operates smoothly, without generating abnormal sounds or vibration.
2. Check the level of the liquid in the suction tank, and the suction pressure.
3. Compare the discharge pressure and current measured during operation with the specifications indicated on the motor and pump nameplates to verify normal pump load.

* Note that the indicated value of the pressure gauge varies in proportion to the specific gravity of the liquid.

* Note that the valve of the pressure gauge or vacuum gauge should be opened only when measurements are recorded. It must be closed after completion of each measurement. If the valve remains open during operation, the gauge mechanism may be affected by abnormal pressure caused by water hammer.

8 PARTS DESCRIPTION AND EXPLODED VIEW

MX-70, MX-100, MX-F100

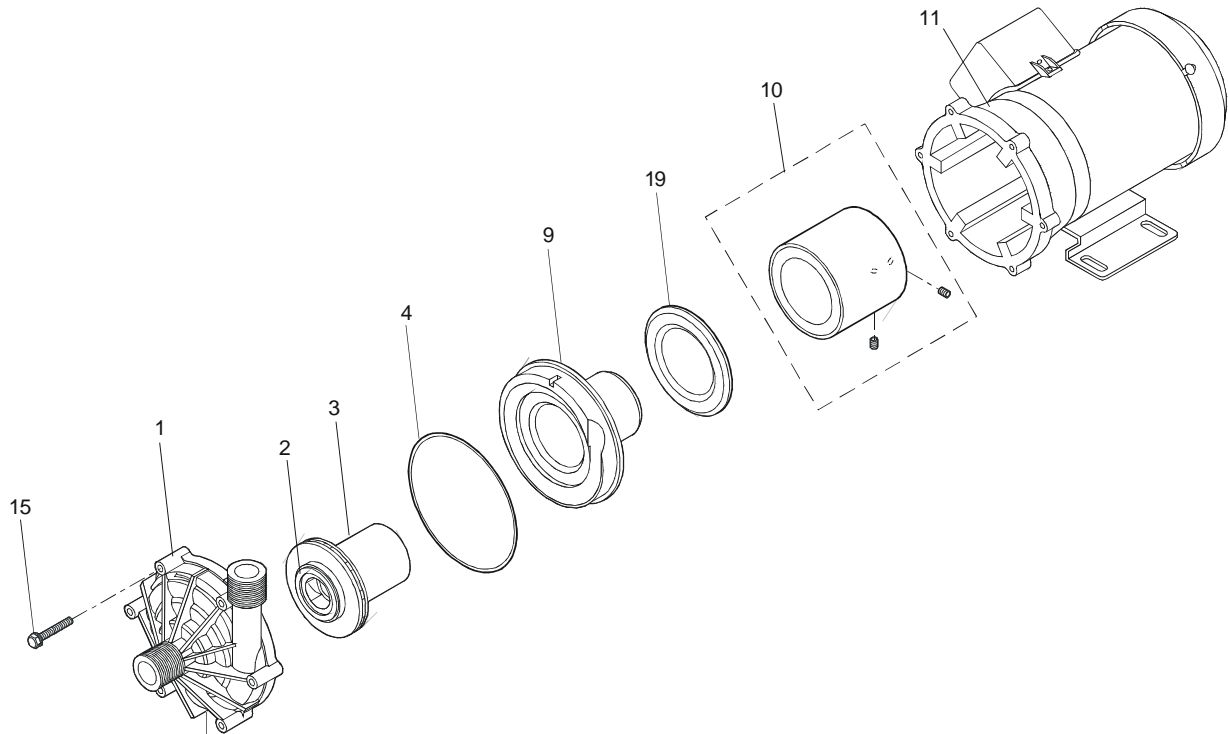

Item No.	Description	Qty
1	Front casing	1
2	Mouth ring	1
3	Impeller	1
4	O-ring	1
9	Rear casing	1

Item No.	Description	Qty
10	Drive magnet	1
11	Motor	1
15	Bolt, front casing	6
19	Retainer/Backup ring*	1

* MX-100/MX-F100 only

9 DIMENSIONS AND WEIGHTS

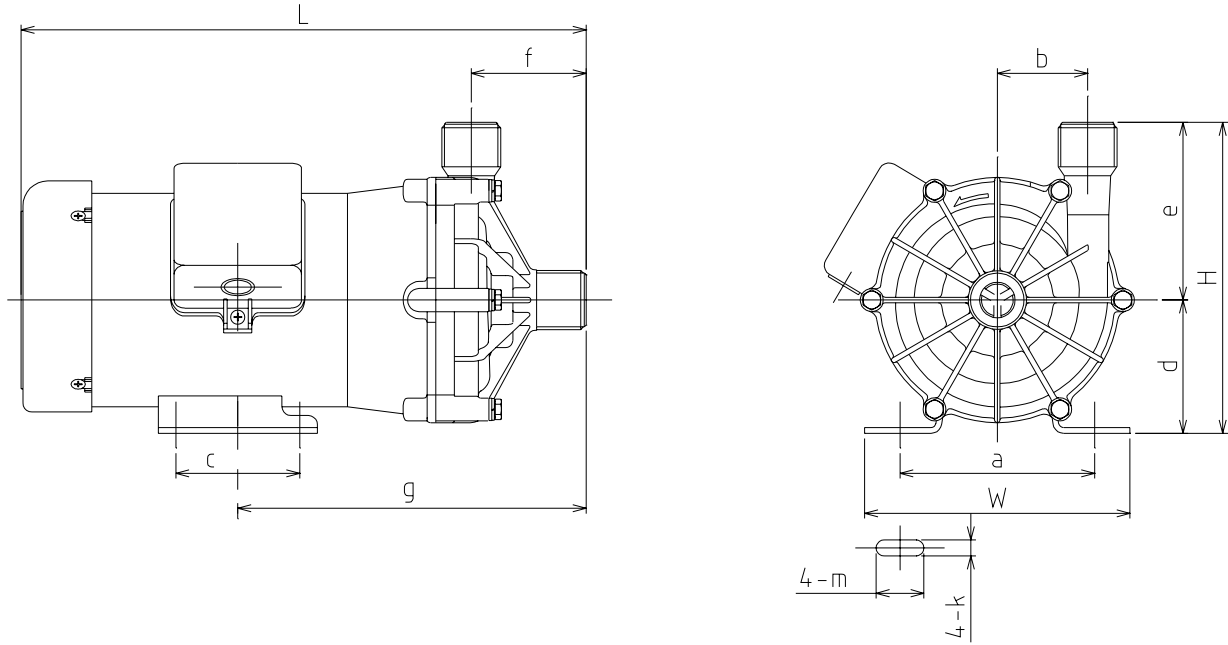

Dimensions in inches (mm)

	W	H	L	a	b	c	d	e	f	g	m	k	Wt. (lbs)
MX-70 (T)	5.12 (130)	6.10 (155)	10.18 (258.5)	4.33 (110)	1.89 (48)	1.57 (40)	2.56 (65)	3.54 (90)	2.09 (53)	7.07 (179.5)	0.28 (7)	0.43 (11)	14.3
MX-100	5.90 (150)	6.89 (175)	12.58 (319.5)	4.33 (110)	2.01 (51)	2.76 (70)	2.95 (75)	3.94 (100)	2.56 (65)	7.76 (197)	0.35 (9)	1.06 (27)	18.1
MX-F100 (Y) (Z)													18.7



5 BOYNTON ROAD HOPPING BROOK PARK HOLLISTON, MA 01746 USA
TEL: 508-429-1440 FAX: 508-429-1386 www.iwakiwalchem.com