

MDM Series

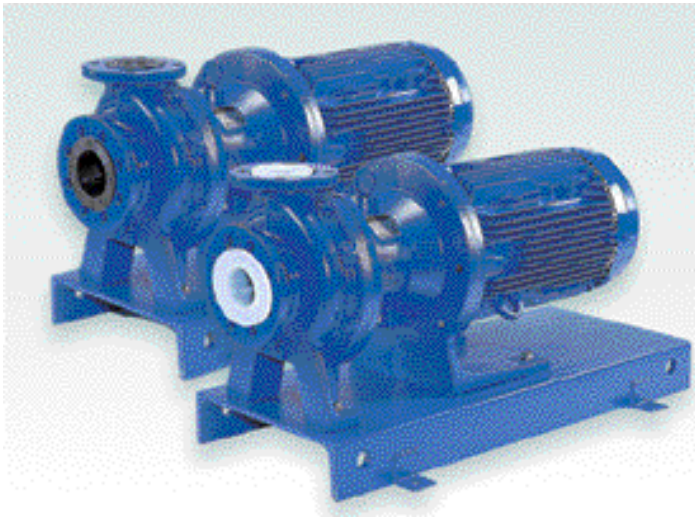

DRY RUN CAPABLE FOR HANDLING TOUGH CHEMICALS

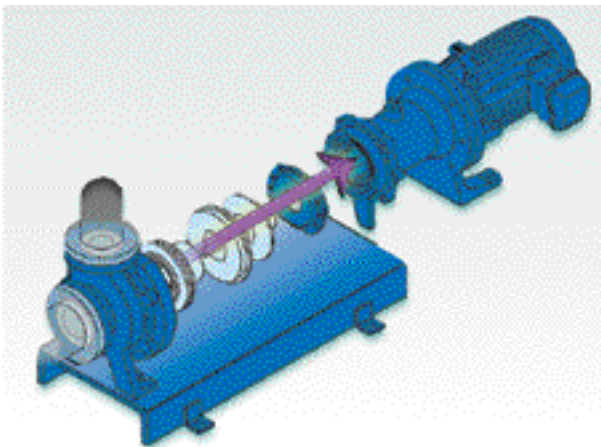

MDM's back pullout design allows the operator to inspect the pump while leaving the line pressurized. The pump features safety measures that prevent liquid from leaking when the foot support is pulled back. MDM's modular design keeps your operating cost low over the life of the pump by making regular maintenance and periodic inspection a snap.

MDM is a wide ranging line of chemical process pumps designed to solve the most demanding chemical handling applications. Two materials of construction and convenient mounting configurations allow MDM to handle many aggressive chemical and high purity applications.

Unexpected dry running won't damage the pump or interrupt the process. Our new design allows the pump to handle these situations with ease.

High purity process fluid will not be contaminated by trace metals due to our combination of high purity materials and meticulous construction.

High strength rare earth magnets are totally encapsulated within fluororesin moldings. Small, lightweight and perfectly concentric magnet capsules optimize pump efficiency.

Installation and maintenance time are reduced with our compact, close-coupled design. Operating costs are reduced thanks to simple, modular construction and individually replaceable parts.

An expanded temperature range (up to 300°F) as well as increased solids handling capabilities (up to 10%) provides users with solutions for their difficult applications.

MDM pumps feature enhanced slurry capability when fitted with a new specially designed bearing system.



MODEL CODE

MDM - **1518** **EKK** **05** **H** **S**

A B C D E

A Pump Size

Model	Suction	Discharge	Motor HP
1516	1½	1	2/3
1518	1½	1	5 / 7.5 / 10
1518-2	1½	1	7.5/10/15/20/25
2156	2	1½	5 / 7.5 / 10
2158	2	1½	7.5/10/15/20/25
2526	2½	2	5 / 7.5 / 10
326	3	2	7.5 / 10 / 15 / 20 / 25

B Liquid End Construction

Materials	ECF	EKK	PKK
1. Front casing	20% CFRETFE	SiC	SiC
2. Rear casing			
3. Impeller			
4. Inner magnet			
5. Bearing	High density Carbon	SiC	SiC
6. Shaft	High purity Alumina Ceramic		
7. Outboard forward thrust collar	PTFE		
8. Inboard front thrust collar	High purity Alumina Ceramic		
9. Inboard rear thrust collar	PTFE (with filler)	PTFE	
10. Outboard rear thrust collar	PTFE		
11. Gasket	Kevlar®		
12. Support*	Kevlar®		

* High temperature versions (1518-2 and 2158) only used on fluids 176°F (80°C) and above.

C Motor Size

02	2 HP	145TC
03	3 HP	182TC
05	5 HP	184TC
07	7 HP	213TC
10	10 HP	215TC
15	15 HP	254TC
20	20 HP	256TC
25	25 HP	284TSC

D H = High Temperature Version
(1518-2 and 2158 only)

E S = Slurry Bearing Design

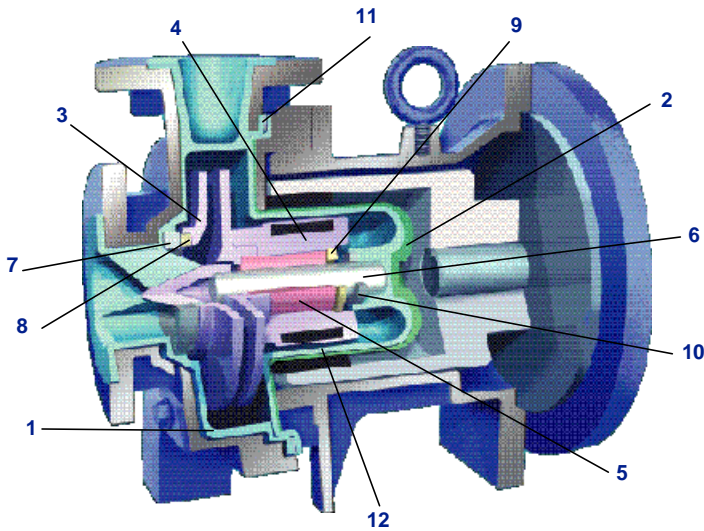

REAR CASING TRIPLE LAYER CONSTRUCTION

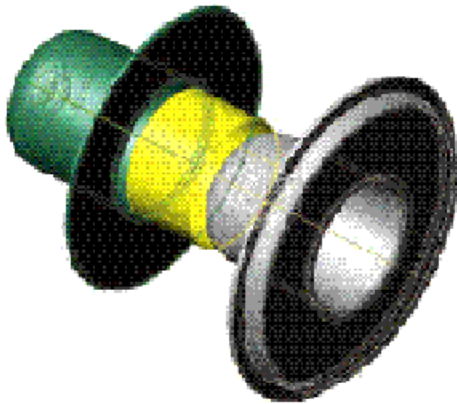

Continuing with the design advantage of individually replaceable containment shells and covers, the MDM high head models utilize a unique three layer design comprised of a separate containment shell, a Kevlar® support piece and the containment shell cover. All are individually replaceable in the field. This combination allows the pumps to be operated at temperatures above 176°F (80°C) and maintain the MAWP of 232 psi. (Patent pending)

PERFORMANCE CURVE

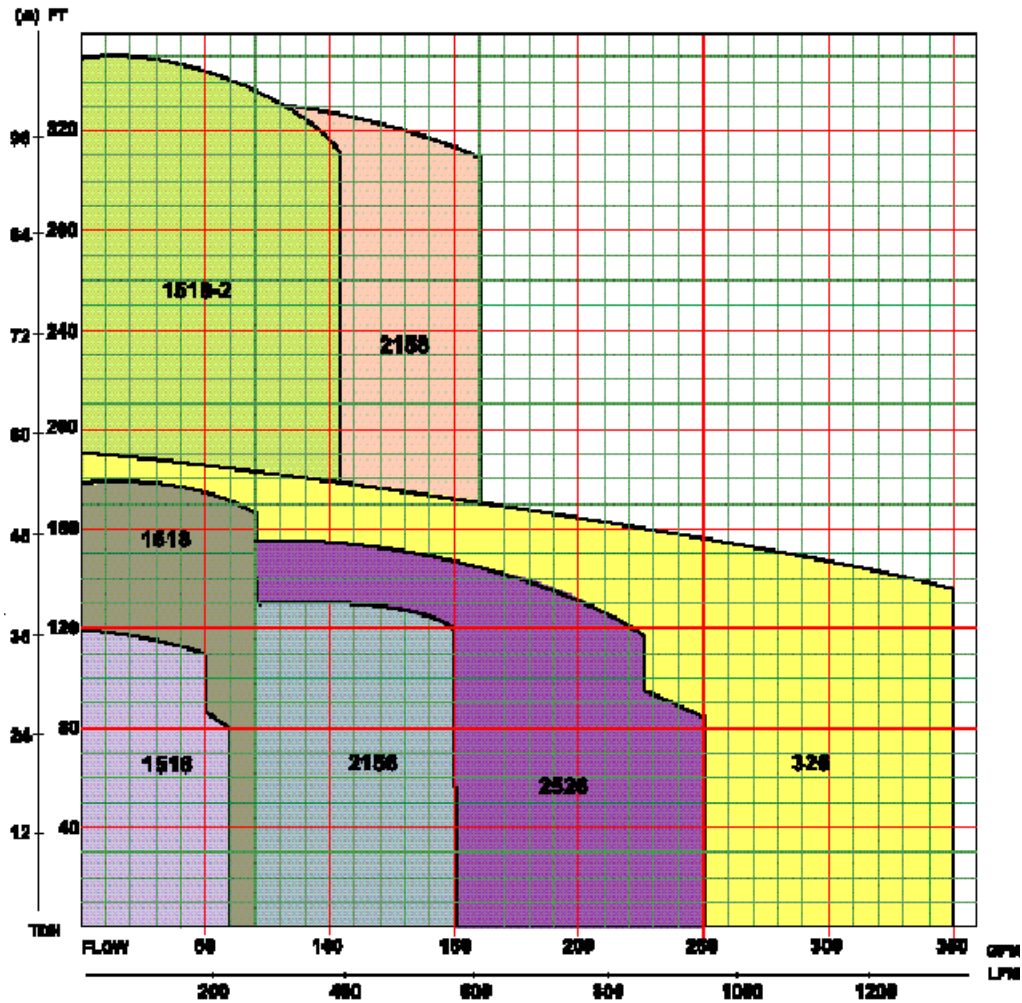

SPECIFICATIONS

Model	Connections Suct x Disch 150# (inch)	Nominal Impeller Dia. (inch)	BEP Capacity @60Hz (GPM)	BEP Head (ft)	Min Flow Rate (GPM)	Nominal Motor (RPM)	Motor (HP)
1516*	1½ x 1	5.52	50	108	5	3500	2,3
1518*	1½ x 1	6.7	70	167	5	3500	5, 7.5, 10
1518-2*	1½ x 1	8.86	120	310	13	3500	7.5, 10, 15, 20, 25
2156	2 x 1½	5.71	150	116	13	3500	5, 7.5, 10
2158	2 x 1½	8.86	130	190	13	3500	7.5, 10, 15, 20, 25
2526	2½ x 2	6.3	225	118	13	3500	5, 7.5, 10
326*	3 x 2	6.7	275	150	13	3500	7.5, 10, 15, 20, 25

* ANSI dimensional pump

LIQUID TEMPERATURE RANGE

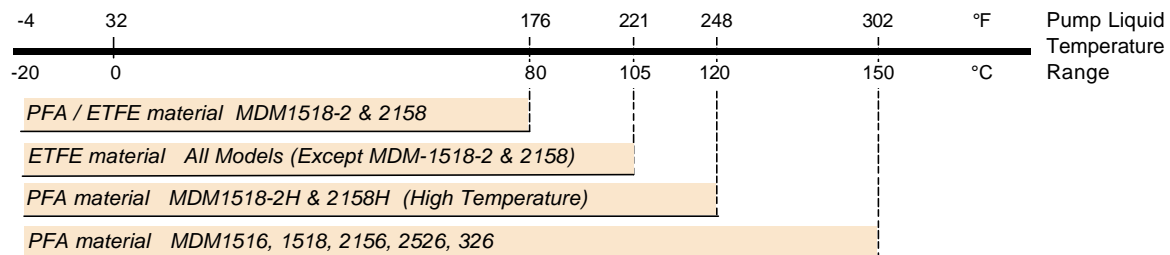

Dimensions

MDM 1516 to 2526, 2-5 HP

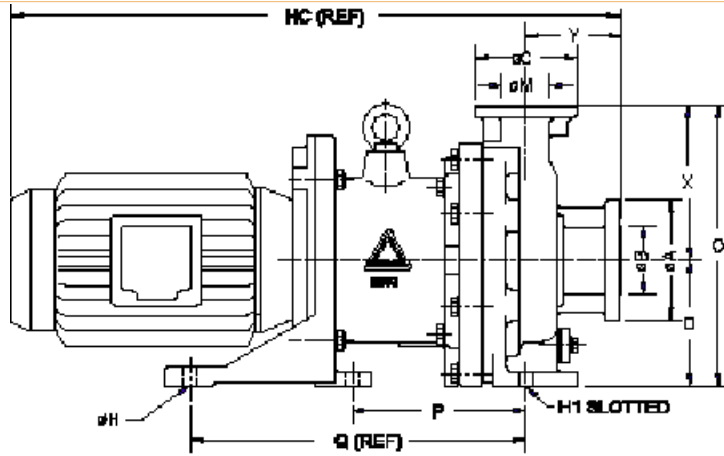

MDM 1516 to 1518-2

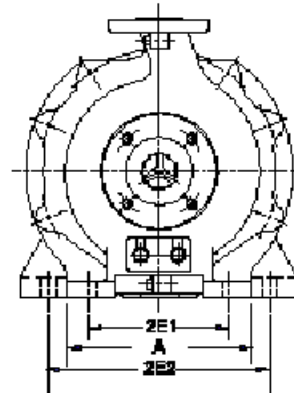

MDM 1518 to 326, 7.5-25 HP

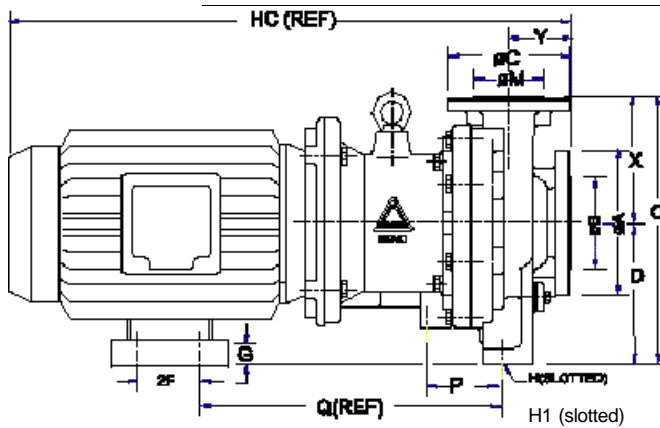

MDM 2156 to 326

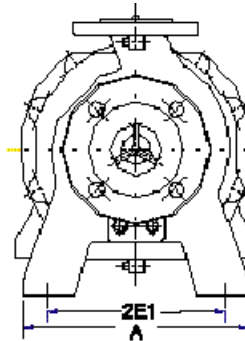

MDM Model	Frame	HC	D	2E1	2E2	A	Q	P	G	H	H1	O	X	Y	Weight w/o Motor
1516*	145TC	20.58 (522.7)	5.25 (133.3)	5.98 (151.9)	9.45 (240.3)	11.42 (290)	9.25 (234.9)	7.25 (184.2)	---	0.63 (16)	0.63 (16)	11.76 (298.7)	6.5 (165.1)	4.0 (101.6)	100
	182TC	29 (736.6)	5.25 (133.3)	5.98 (151.9)	9.45 (240.3)	7.87 (199.9)	14.09 (357.9)	7.25 (184.2)	---	0.63 (16)	0.63 (16)	11.76 (298.7)	6.5 (165.1)	4.0 (101.6)	100
1518*	184TC	30 (762)	5.25 (133.3)	5.98 (151.9)	9.45 (240.3)	7.87 (199.9)	14.09 (357.9)	7.25 (184.2)	---	0.63 (16)	0.63 (16)	11.76 (298.7)	6.5 (165.1)	4.0 (101.6)	132
	213-215TC	33.5 (850.9)	5.25 (133.3)	5.98 (151.9)	---	7.87 (199.9)	14.07 (357.4)	4.09 (103.9)	---	0.63 (16)	0.63 (16)	11.76 (298.7)	6.5 (165.1)	4.0 (101.6)	132
1518-2*	213-215TC	29.5 (749.3)	5.25 (133.3)	6.0 (152.4)	---	8.66 (219.9)	14.46 (367.3)	4.09 (103.9)	---	---	0.55 (13.9)	11.76 (298.7)	6.5 (165.1)	4.0 (101.6)	143
	254-256TC	33.5 (850.9)	6.25 (158.7)	6.0 (152.4)	---	9.84 (249.9)	14.97 (380.2)	4.09 (103.9)	---	---	0.55 (13.9)	12.75 (323.8)	6.5 (165.1)	4.0 (101.6)	154
	284TSC	37.35 (948.7)	7.00 (177.8)	6.0 (152.4)	---	9.84 (249.9)	14.97 (380.2)	4.09 (103.9)	0.75 (19)	---	0.55 (13.9)	13.50 (342.9)	6.5 (165.1)	4.0 (101.6)	154
	2156	184TC	29 (736.6)	7.09 (180)	8.66 (219.9)	---	11.02 (279.9)	13.68 (347.5)	6.89 (175)	1.83 (46.5)	0.63 (16)	0.55 (13.9)	13.39 (340.1)	6.3 (160)	3.15 (80)
2156	213-215TC	31 (787.4)	7.09 (180)	8.66 (219.9)	11.02 (279.9)	11.02 (279.9)	14.45 (367)	3.70 (93.9)	3.54 (89.9)	0.55 (13.9)	0.38 (9.6)	13.39 (340.1)	6.3 (160)	3.15 (80)	132
	2158	213-215TC	28.62 (726.9)	5.26 (133.6)	8.66 (219.9)	---	11.02 (279.9)	20.07 (509.8)	3.70 (93.9)	1.84 (46.7)	---	0.55 (13.9)	14.17 (359.9)	7.09 (180)	3.15 (80)
2158	254-256TC	32.67 (829.8)	7.09 (180)	8.66 (219.9)	---	11.02 (279.9)	19.57 (497)	3.70 (93.9)	0.84 (21.3)	---	0.55 (13.9)	14.17 (359.9)	7.09 (180)	3.15 (80)	165
	284TSC	36.5 (927.1)	7.09 (180)	8.66 (219.9)	---	11.02 (279.9)	20.27 (514.8)	3.58 (90.9)	---	---	0.55 (13.9)	14.17 (359.9)	7.09 (180)	3.15 (80)	165
2526	184TC	29 (736.6)	7.09 (180)	8.66 (219.9)	11.02 (279.9)	---	13.68 (347.5)	6.89 (175.01)	1.83 (46.5)	0.38 (9.6)	0.55 (13.9)	13.39 (340.1)	6.3 (160)	3.15 (80)	132
	213-215TC	31 (784.4)	7.09 (180)	8.66 (219.9)	11.02 (279.9)	---	14.45 (367)	3.70 (93.98)	3.54 (89.9)	0.55 (13.9)	0.38 (9.6)	13.39 (340.1)	6.3 (160.02)	3.15 (80)	132
326*	213-215TC	31 (784.4)	8.25 (209.5)	9.76 (247.9)	---	11.81 (299.9)	14.47 (367.5)	4.09 (103.9)	2.99 (75.9)	0.63 (16)	---	16.5 (419.1)	8.25 (209.5)	4.0 (101.6)	144
	254-256TC	36 (914.4)	8.25 (209.5)	9.76 (247.9)	---	11.81 (299.9)	14.97 (380.2)	4.09 (103.9)	1.99 (50.5)	0.63 (16)	---	16.5 (419.1)	8.25 (209.5)	4.0 (101.6)	144
	284TSC	37.35 (948.7)	8.25 (209.5)	9.76 (247.9)	---	11.81 (299.9)	14.97 (380.2)	4.09 (103.9)	1.25 (31.8)	0.63 (16)	---	16.5 (419.1)	8.25 (209.5)	4.0 (101.6)	144

* Meet ANSI B73.3M dimensional standards