

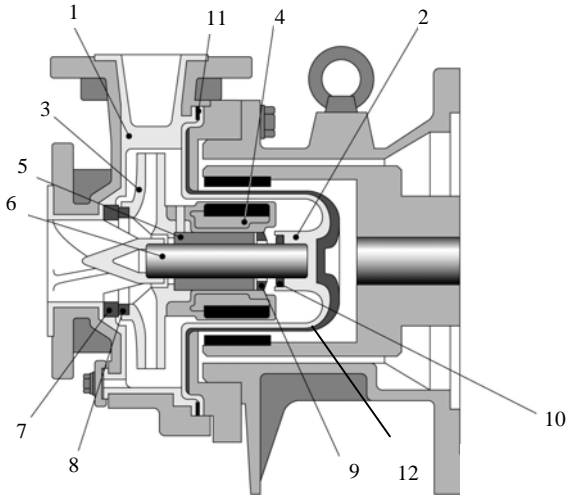

MDM-2158 15/20HP

- ❑ Exceeds ANSI Performance standards
- ❑ Simple, rugged, modular design
- ❑ Dual back pull-out
- ❑ Alpha sintered SiC bearing system



Part	Material	
	EKK	PKK
1 Front casing	CFRETFE (carbon fiber reinforced ETFE)	PFA
2 Containment shell		
3 Impeller		
4 Inner magnet assy		
5 Bearing	SiC	
6 Shaft		
7 Front outboard thrust collar		
8 Front inboard thrust collar		
9 Rear inboard thrust collar		
10 Rear outboard thrust collar	PTFE (filler charged)	PTFE
11 Gasket	PTFE	
12 Support	Kevlar®	

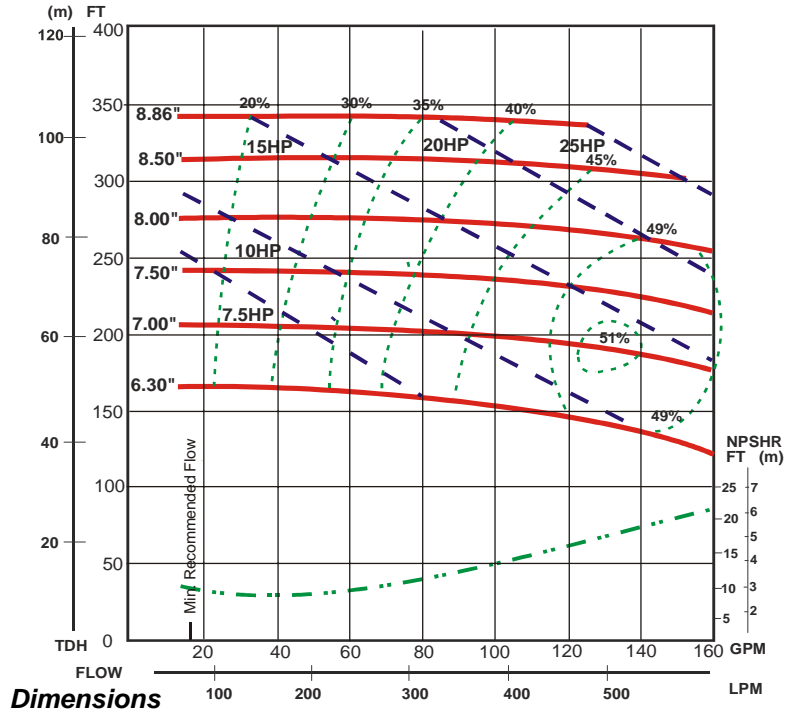

(inches) and Specifications

Note: Will vary by motor manufacturer

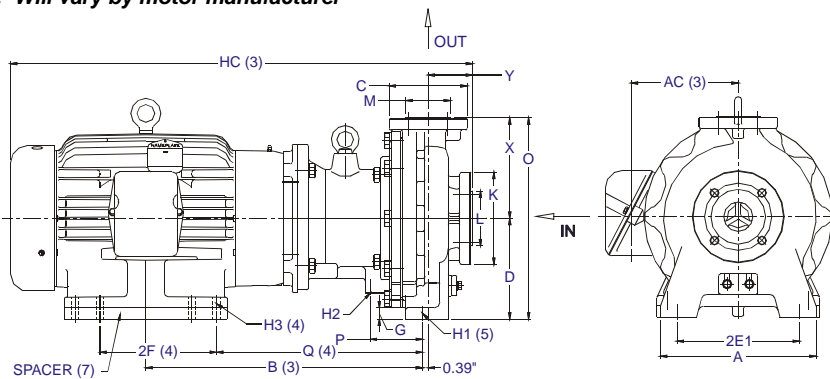

*Pump end only. Does not include motor.

A	AC(3)	B(3)	D	2E1	2F(4)	G	H1(5)	H2	H3(4)	HC(3)	O	P	Q(4)	X	Y
11.02	7.56	19.57	7.00	8.66	8.25/ 10.00	0.70	0.55	3/8-16UNC	0.52	32.67	14.09	3.70	14.57	7.09	3.15
HP/Frame		Connection Sizes		Min Flow/Max Head		Standard Capacity		Max Capacity		Pump Weight*		K	L	C	M
15/254TC & 20/256TC		2 x 1.5		13/343		125		160		165		6.50	3.86	5.51	2.75