

# MDM-1516 3 HP

- ❑ Non-contact Bearing System allows dry run operation (CF models only)
- ❑ Simple, rugged design
- ❑ Corrosion resistant ETFE & PFA internals
- ❑ Spline/pinned impeller design (pat. pending) provides positive locking of impeller/inner magnet while still allowing for individual replacement of each part
- ❑ PFA version temperatures to 302°F

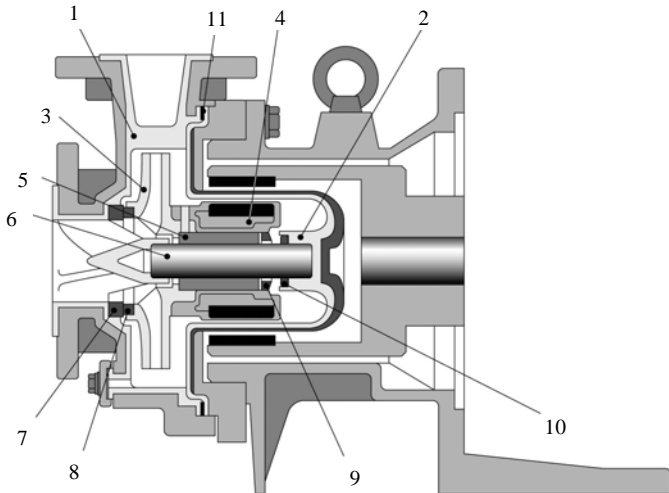

Part	Material		
	ECF	EKK	PKK
1 Front casing	CFRETFE (carbon fiber reinforced ETFE)	SiC	PFA
2 Containment shell			
3 Impeller			
4 Inner magnet assy			
5 Bearing	High density carbon	SiC	
6 Shaft	High purity alumina ceramic		
7 Front outboard thrust collar			
8 Front inboard thrust collar			
9 Rear inboard thrust collar	High purity alumina ceramic		
10 Rear outboard thrust collar	PTFE (filler charged)	PTFE	
11 Gasket	PTFE		

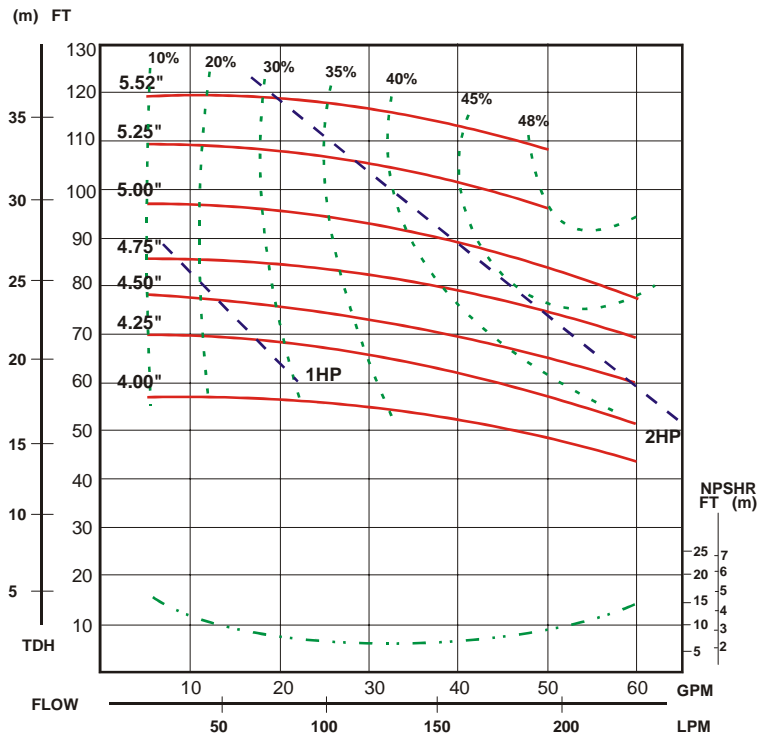

**Dimensions (inches) and Specifications**  
**Note: Will vary by motor manufacturer**

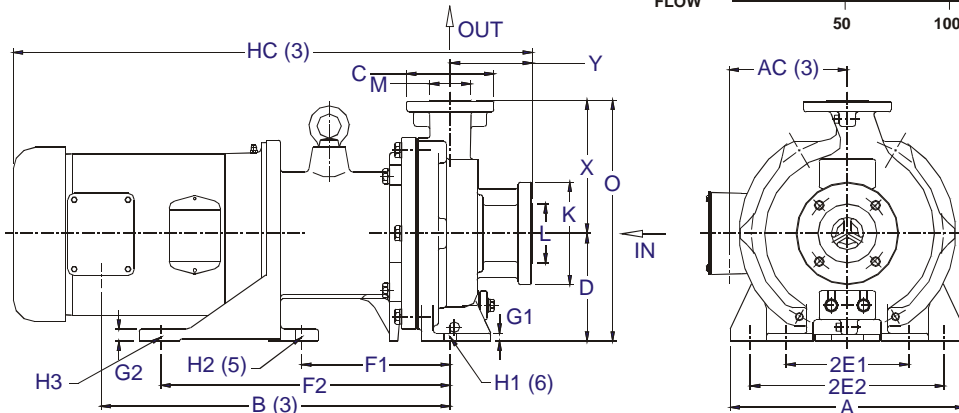

A	AC(3)	B(3)	D	2E1	2E2	F1	F2	G1	G2	H1 (6)	H2 (5)	H3	HC (3)	O	X	Y
11.42	5.76	17.01	5.26	5.98	9.45	7.24	14.09	0.39	0.59	0.63	0.63	0.63	25.29	11.76	6.50	4.00
HP/Frame		Connection Sizes		Min Flow/Max Head		Standard Capacity		Max Capacity		Pump Weight*		K	L	C	M	
3/182TC		1.5 x 1		5/120		20		60		110		5.00	2.87	4.25	2.00	

\* Pump end only. Does not include motor.