

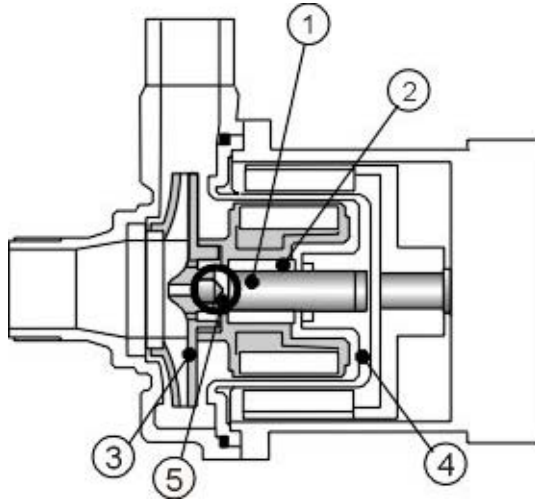

# IWAKI WALCHEM Corporation

# MDH-F425



- Patented Pinpoint Bearing System allows dry run operation
- Rare earth Neodymium magnets
- Compact design
- Flush grooves cool main bearing
- Mounts to standard NEMA C-faced motors
- Carbon fiber reinforced ETFE wetted parts

Part	Material
1 Spindle	Alumina Ceramic
2 Bearing	Carbon, Alumina Ceramic
3 Impeller	ETFE
4 Rear Casing	ETFE
5 Pinpoint Bearing System	Alumina Ceramic

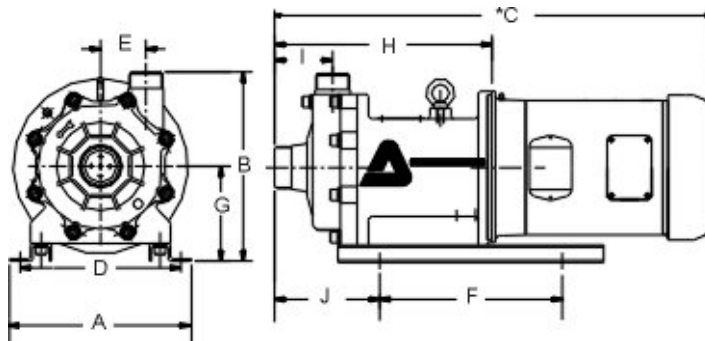
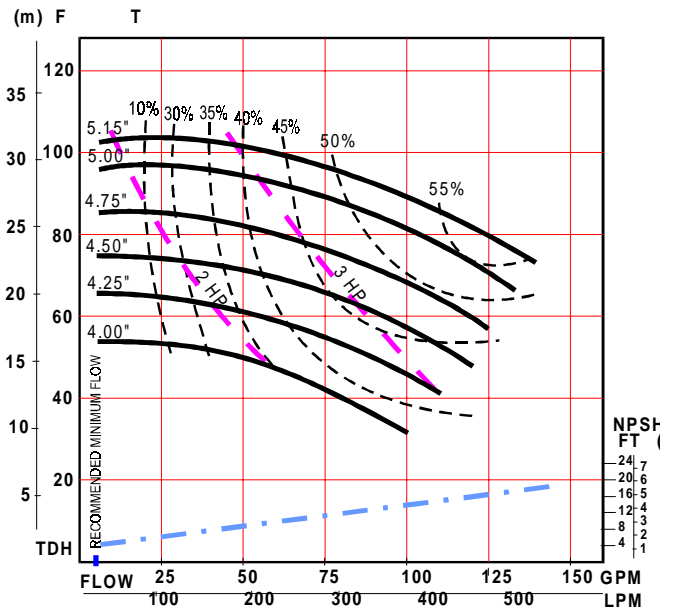

### Dimensions (inches) and Specifications

\* Will vary by motor manufacturer

HP	NEMA	A	B	C	D	E	F	G	H	I	J
5	184TC	10.24	10.59	23.68	9.06	2.56	10.28	5.31	12.24	3.27	5.91
Connection Sizes	Motor Output (hp)	Motor Speed (rpm)	Max Flow (gpm)	Max Head (ft)	Working Pressure (psi)	Specific Gravity	Weight Pump Only (lbs)				
2 x 1½	5	3500	150	102	56	1.2	44				