

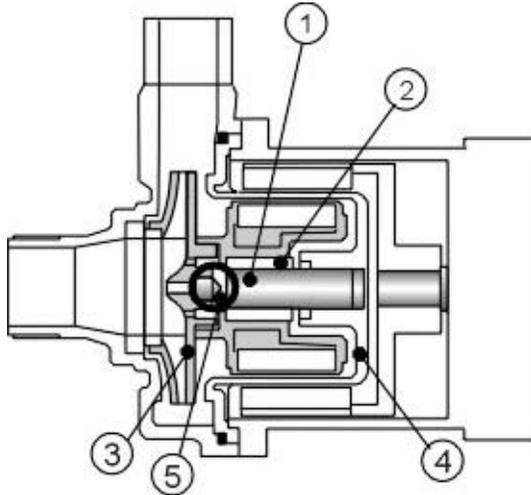

# IWAKI WALCHEM Corporation

# MDH-422



- Patented Pinpoint Bearing System allows dry run operation
- Rare earth Neodymium magnets
- Compact design
- Flush grooves cool main bearing
- Mounts to standard NEMA C-faced motors
- Glass fiber reinforced polypropylene wetted parts

Part	Material
1 Spindle	Alumina Ceramic, 316 SS
2 Bearing	Carbon, PTFE
3 Impeller	GFRPP
4 Rear Casing	GFRPP
5 Pinpoint Bearing System	Alumina Ceramic

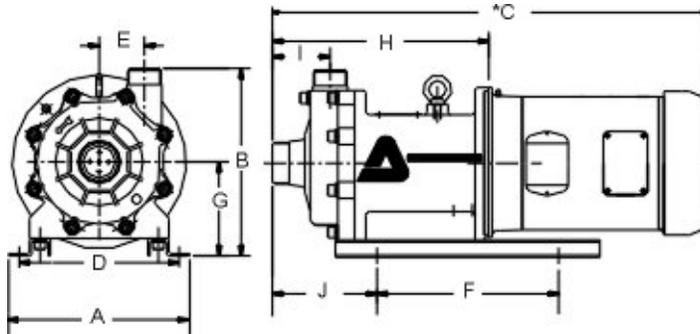
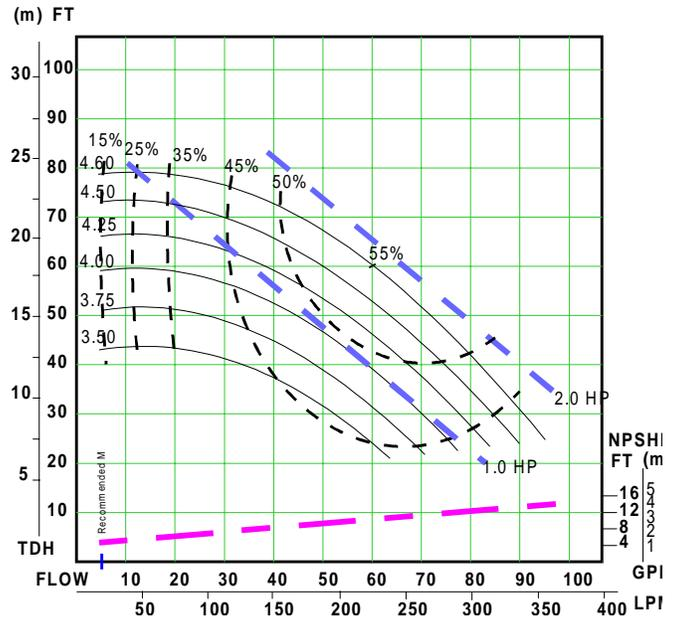

### Dimensions (inches) and Specifications

\* Will vary by motor manufacturer

HP	NEMA	A	B	C	D	E	F	G	H	I	J
2	145TC	10.24	9.81	21.23	8.19	2.56	7.87	4.53	11.26	3.27	5.83
Connection Sizes	Motor Output (hp)	Motor Speed (rpm)	Max Flow (gpm)	Max Head (ft)	Working Pressure (psi)	Specific Gravity	Weight Pump Only (lbs)				
2 x 1½	2	3500	95	79	43	1.2	33				