

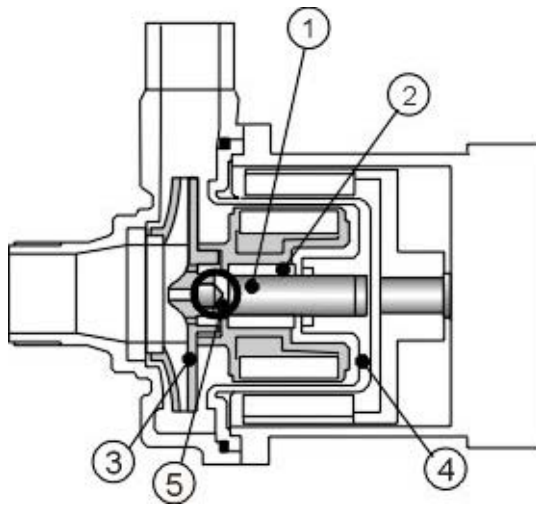

**IWAKI WALCHEM Corporation**

# MDH-401-7



- Patented Pinpoint Bearing System allows dry run operation (with CV models only)
- Flush grooves cool main bearing
- Mounts to standard NEMA motors
- Glass fiber reinforced polypropylene wetted parts

| Part                      | Material                |
|---------------------------|-------------------------|
| 1 Spindle                 | Alumina Ceramic, 316 SS |
| 2 Bearing                 | Carbon, PTFE            |
| 3 Impeller                | GFRPP                   |
| 4 Rear Casing             | GFRPP                   |
| 5 Pinpoint Bearing System | Alumina Ceramic, Carbon |

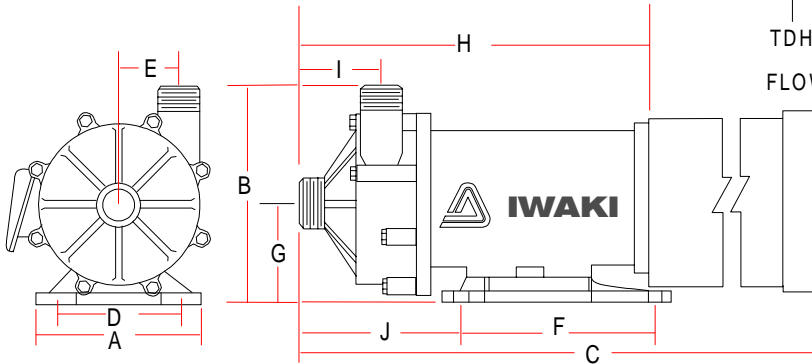
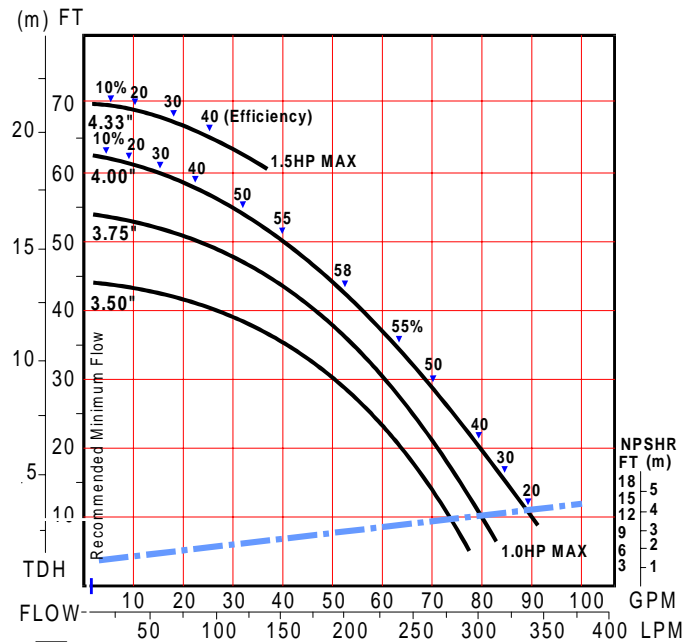

### Dimensions (inches) and Specifications

\* Will vary by motor manufacturer

| HP               | NEMA              | A                 | B              | C*            | D                      | E                | F                      | G    | H     | I    | J    |
|------------------|-------------------|-------------------|----------------|---------------|------------------------|------------------|------------------------|------|-------|------|------|
| 1½               | 56C               | 6.30              | 9.76           | 21.38         | 5.12                   | 2.26             | 5.12                   | 4.53 | 11.50 | 3.84 | 7.01 |
| Connection Sizes | Motor Output (hp) | Motor Speed (rpm) | Max Flow (gpm) | Max Head (ft) | Working Pressure (psi) | Specific Gravity | Weight Pump Only (lbs) |      |       |      |      |
| 1½ x 1½          | 1½                | 3600              | 92             | 70            | 34                     | 1.1              | 24                     |      |       |      |      |