

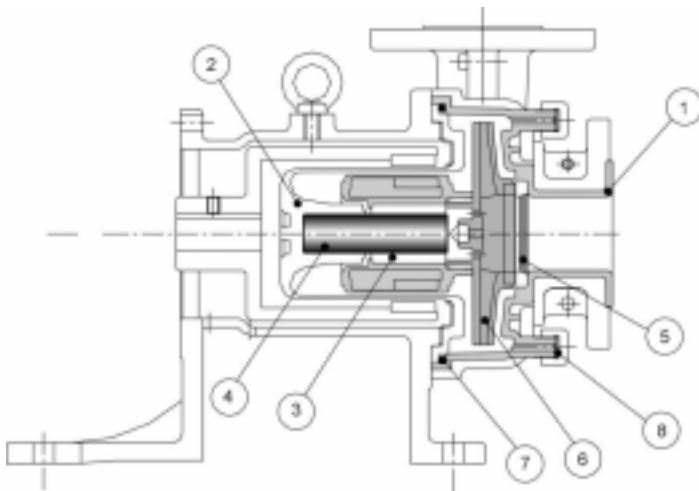

IWAKI WALCHEM Corporation

MDF-L401



- Patented Pinpoint Bearing System allows dry run operation (CF models only)
- Compact design
- Corrosion resistant ETFE internals
- Precision injection molded, individually replaceable, liner components for simple on site maintenance

Part	Material	
	CF	AA
1 Casing Liner	20% carbon reinforced fluoroplastic	
2 Containment shell	ETFE	
3 Bushing	High density carbon	99.8% alumina ceramic
4 Shaft	99.8% alumina ceramic	
5 Thrust collar, inboard		
6 Impeller	20% carbon reinforced fluoroplastic ETFE	
7 O-ring	FKM / EPDM / AFLAS	
8 Gasket	Teflon with optional backing materials (EPDM / FKM / AFLAS)	

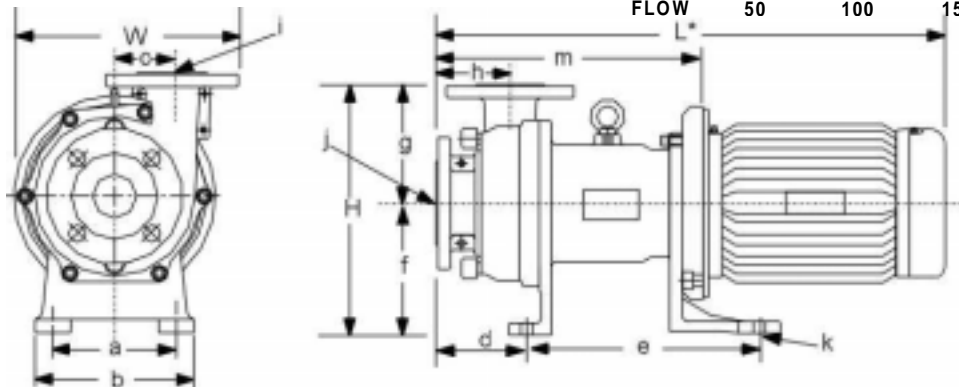
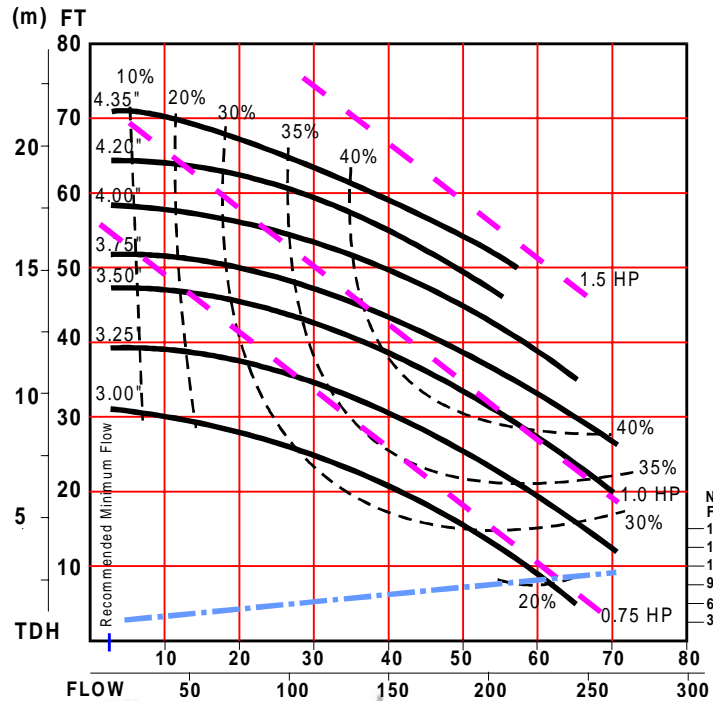

Dimensions (inches) and Specifications

* Will vary by motor manufacturer

a	b	c	d	e	f	g	h	i	j	m	k	W	H	L
5.1"	6.7"	2.3"	4.4"	9.8"	5.3"	5.5"	4.0"	1.5"	1.5"	11.8"	0.55"	9.2"	10.8"	20.4"
Connection Sizes		Min Flow/Max Head		Standard Capacity		Max Capacity		Motor/Frame		Pump Weigh				
1.5 x 1.5		2.5 GPM/ 71 ft.		50 GPM/ 54 ft.		70 GPM		1½ HP/ 56C		48 lbs.				