

1 2 3 4 5 6 7 8 9 10 11 12 13 14 15 16 17 18 19 20 21 22 23 24 25

PART OR DRAWING NO. IF20575 REV. A

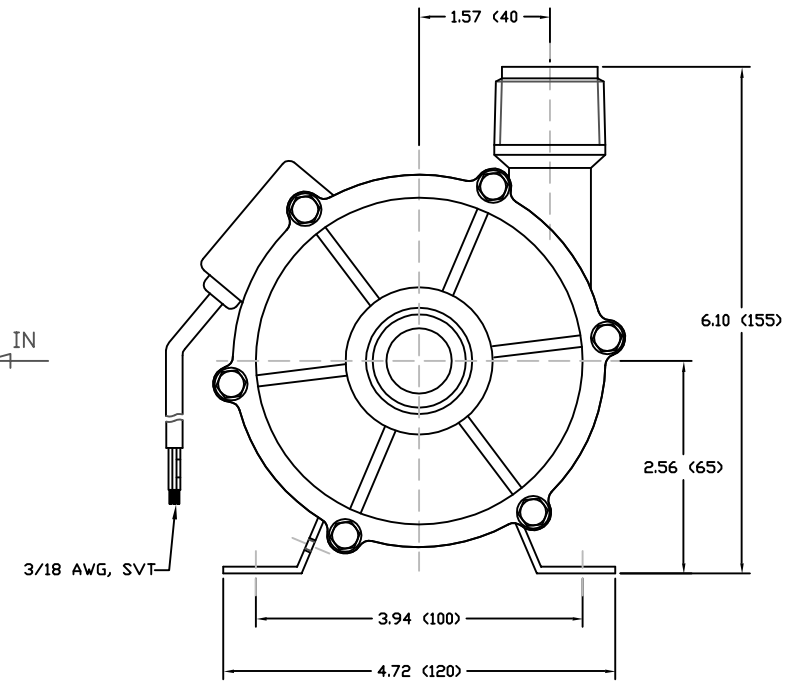
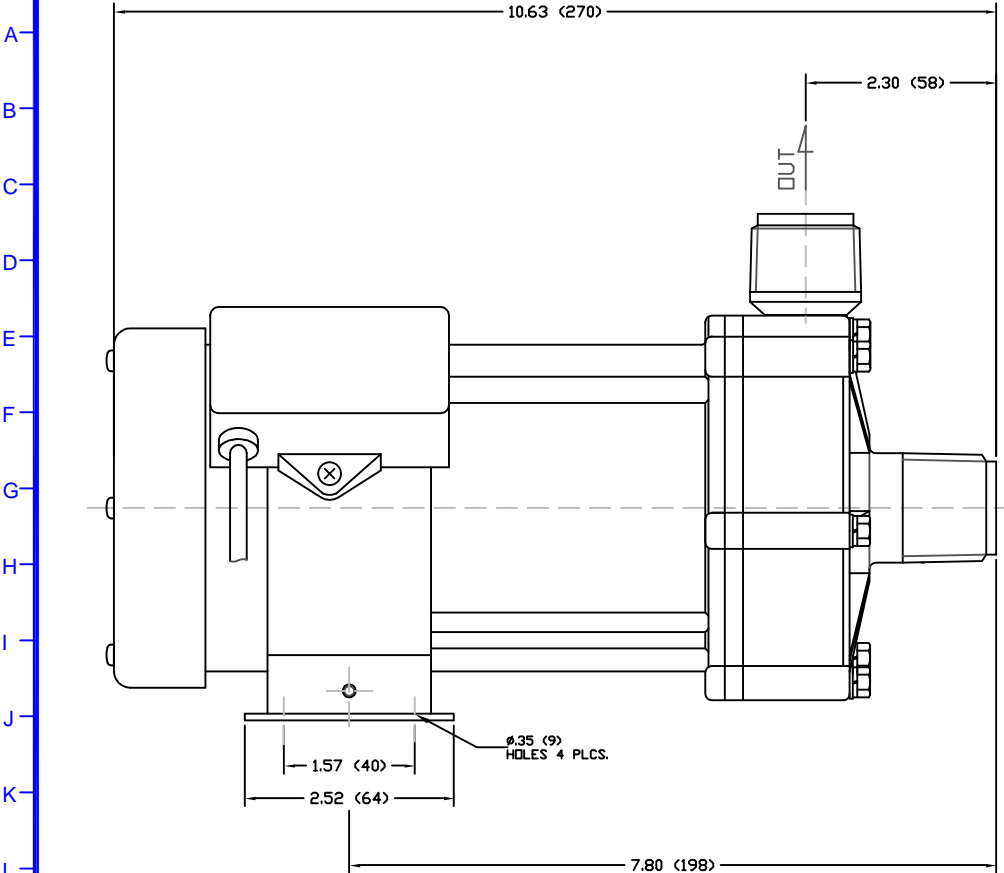

- NOTES:
 1. DRAWING MAY VARY FROM ACTUAL PRODUCT
 2. DRAWN FROM 2Z000417 TO SCALE.
 3. REFER TO CONSTRUCTION DRAWING 2A32494.
 4. DIMENSIONS ARE IN INCHES (MM).

SPECIFICATIONS	
MAX CAPACITY	17.1 GPM (64.7 LPM)
MAX HEAD	25.6 FT (7.8M)
MAWP	21.3 PSI (1.5 MPA)
VOLTAGE	115 VAC
CURRENT	1.9 A
CORD LENGTH	39.4 IN (1 M)
WEIGHT	11.9 LBS (5.4 KG)
SUCTION	1 IN NPT - MALE
DISCHARGE	1 IN NPT - MALE

MATERIALS	
CASING	CFRETFE
IMPELLER	CFRETFE
SPINDLE	SIC
BEARING	SIC
THRUST RING	SIC
O-RING	FKM-A

ECO#	DESCRIPTION	DATE	REV. LTR.
MATERIAL SEE CHART			
GJS	04 03 05	XXX	1
DRAWN	DAY MO. YR.	RELEASED	SHEET NO.
		5 Boynton Rd. Hopping Brook Park Holliston, MA 01746 (508) 429-1440 www.IwakiAmerica.com	
TITLE			REV.
MAG DRIVE PUMP MD-55LFY (115V)			A

PART OR DWG. NO. IF20575