



***IWAKI AMERICA***  
***MXM SERIES***  
***MAGNETIC DRIVE PUMP***  
***INSTRUCTION MANUAL***



**MXM SERIES INSTRUCTION MANUAL**  
**Table of Contents**

<b>1</b>	<b>SAFETY INSTRUCTION .....</b>	<b>1</b>
<b>2</b>	<b>CAUTION .....</b>	<b>2</b>
<b>3</b>	<b>UNPACKING AND INSPECTION .....</b>	<b>3</b>
<b>4</b>	<b>MODEL IDENTIFICATION .....</b>	<b>4</b>
<b>5</b>	<b>SPECIFICATIONS .....</b>	<b>5</b>
<b>6</b>	<b>MATERIALS OF CONSTRUCTION .....</b>	<b>6</b>
<b>7</b>	<b>HANDLING INSTRUCTIONS .....</b>	<b>7</b>
<b>8</b>	<b>INSTALLATION, PIPING, AND WIRING .....</b>	<b>10</b>
	■ <i>INSTALLATION POSITION .....</i>	<i>10</i>
	■ <i>INSTALLATION.....</i>	<i>10</i>
	■ <i>PIPING .....</i>	<i>11</i>
	■ <i>SUCTION PIPING.....</i>	<i>11</i>
	■ <i>DISCHARGE PIPING .....</i>	<i>13</i>
	■ <i>WIRING .....</i>	<i>14</i>
<b>9</b>	<b>OPERATION.....</b>	<b>15</b>
	■ <i>NOTES ON OPERATION .....</i>	<i>15</i>
	■ <i>START-UP PREPARATION .....</i>	<i>15</i>
	■ <i>STARTING OPERATION STEPS.....</i>	<i>16</i>
	■ <i>STOPPING OPERATION STEPS .....</i>	<i>17</i>
<b>10</b>	<b>MAINTENANCE AND INSPECTION .....</b>	<b>17</b>
	■ <i>DAILY INSPECTION.....</i>	<i>17</i>
	■ <i>PERIODIC INSPECTION.....</i>	<i>18</i>
	■ <i>REPLACEMENT TOLERANCE CHART .....</i>	<i>20</i>
<b>11</b>	<b>TROUBLESHOOTING .....</b>	<b>21</b>
<b>12</b>	<b>PARTS DESCRIPTION AND EXPLODED VIEW .....</b>	<b>23</b>
<b>13</b>	<b>DISASSEMBLY AND ASSEMBLY OF PUMP .....</b>	<b>24</b>
	■ <i>DISASSEMBLY .....</i>	<i>24</i>
	■ <i>REASSEMBLY.....</i>	<i>28</i>
<b>14</b>	<b>SPARE PARTS .....</b>	<b>30</b>
<b>15</b>	<b>DIMENSIONS AND WEIGHTS.....</b>	<b>31</b>

*This product is protected by patents.*

Thank you for selecting an Iwaki America MXM Series magnetic drive pump. This instruction manual explains the correct handling, operating, maintenance, inspection and troubleshooting procedures for your pump. Please read through it carefully to ensure the optimum performance, safety and long service of your pump.

## 1 Safety Instruction

---



### **WARNING:**

**1. Pay attention to the magnet field**

The magnet drive pump has a pair of strong magnets. The strong magnet field could adversely affect any persons who are assisted by electronic devices such as the pacemaker, etc.

**2. Be sure to turn off power** prior to any inspection/maintenance and installation works. Be careful power is not turned on unintentionally while working on the pump. In a noisy or dark place, display a sign of "Men Working" near the power supply switch.

**3. Wear protective clothing**

When arranging piping or dismantling the pump, wear protective clothing such as safety goggles, protective gloves etc.

**4. Lifting pump**

When lifting the pump, apply a chain or belts to the eye bolts to keep the pump horizontal.

**5. Do not remodel pump**

Do not remodel the pump. Iwaki America is not responsible for any personal injury or damage to the pump due to modifications.

**6. Handling of dangerous liquids**

For the transfer of the dangerous liquids mentioned below, be sure to conduct daily inspection and maintenance for the prevention of liquid leakage or other failure. Liquid leakage may result in a personal injury, explosion or fire.

- Explosive or flammable liquids
- Corrosive or stimulus toxic liquids
- Harmful liquids to human health

**7. Preventative measure against harmful gas**

When handling harmful chemical gas, provide a preventative measure such as installation of an air fan.

## 2 Caution



### 1. Attention to magnetic force

Strong magnets are used in this pump. Personal injury may be caused from the strong magnetic force. Follow the procedure on "Disassembly and Assembly of Pump" when conducting maintenance work.

### 2. Do not run pump dry

Do not run pump dry. Frictional heat generated under dry run conditions can cause damage to the pump. NEVER operate the pump with a suction side valve closed.

### 3. Restriction on pump operator

The pump must be handled or operated by a qualified person with a full understanding of the pump.

### 4. For specified application only

The use of the pump in any application other than those clearly specified may result in the failure or damage to the pump.

### 5. Countermeasure against static electricity

When low electric conductivity liquid such as the ultra-pure water and the fluor inactive liquid (e.g. Fluorinert™) are handled, static electricity may generate in the pump, which may cause a static discharge resulting in damage to the pump. Countermeasure must be taken to remove static electricity.

### 6. Air elimination prior to pumping operation

Eliminate air in the pump chamber before operating the pump. Care must be taken to eliminate air when handling fluids which easily generate bubbles (hydrogen peroxide, sodium hypochlorite, etc.). Any operation with air remaining in the pump chamber may cause frictional heat and result in damage to the pump.

### 7. Countermeasure against efflux

Take protective measures against the accidental efflux caused by damage to the pump or piping. Also, take an appropriate measure for preventing any spilled liquid from directly soaking into the ground.

### 8. Pump disposal

A used or damaged pump must be disposed of in accordance with local laws and regulations.

### 3 Unpacking and Inspection

---

Open the package and check that the product conforms to your order. Also, check each of the following points. For any problem or inconsistency, contact your distributor at once.

1. Check that the model number and the HP indicated on the nameplate conform to the specifications of your order.
2. Check that all the accessories you ordered are included.
3. Check that the pump body and parts have not been accidentally damaged or that any bolts or nuts have not been loosened in transit.
4. If the pump has shipped without motor, check that the motor adapter is in the proper orientation for your installation.

IWAKI Mag Drive Pump			
MODEL MXM			
HEAD (FT.)			
CAPACITY (GPM)			
HP	60 Hz.		RPM
SERIAL NO.			
HOLLISTON, MA			
<a href="http://www.iwakiamerica.com">www.iwakiamerica.com</a>			

## 4 Model Identification

<b>MXM-</b>	<b>54</b>	<b>2</b>	<b>1</b>	<b>CF</b>	<b>V</b>	<b>H</b>	<b>-XX</b>
	1	2	3	4	5	6	7

### 1 Connection Size

Model	Suction	Discharge
22	1"	1"
44	1.5"	1.5"
54	2"	1.5"

### 2 Motor Output

Model	HP
0	½ HP
1	1 HP
2	2 HP
3	3 HP
5	5 HP

### 3 Impeller Range

Code Number
1
2
3 (54 only)
4 (54 only)

### 4 Materials of Construction

Material Code	CF	FF	KK
Front casing liner/Rear casing	CFRETFE		
Impeller/Magnet Capsule			
Bearing	High Density Carbon	High Purity Alumina Ceramic	SiC
Spindle	High Purity Alumina Ceramic		
Liner Ring	High Purity Alumina Ceramic		
Mouth Ring	PTFE		
Rear Thrust Ring	CFRPFA		

### 5 O-ring /Gasket Material:

V: FKM (Fluoroelastomer)	E: EPDM	A: AFLAS®
--------------------------	---------	-----------

### 6 H: Rear Casing with Cover – High Temperature version

### 7 Special Configuration: 2 digit numeric code denoting special configuration

## 5 Specifications

Model	Connections Suction x Discharge	Impeller Code	Min flow GPM	Max. Head (Ft.)	Max Capacity GPM	Motor/ Frame	Pump Weight lbs
MXM-221_	1" x 1" (25.4mm x 25.4mm)	1	2.5	38	55	½ - ¾ HP/56C	45
MXM-222_		2	2.5	63	55		
MXM-441_	1.5" x 1.5" (38.1mm x 38.1mm)	1	5.3	80	75	1 HP/56C	55
MXM-442_		2	5.3	95	72	2 HP/145TC	60
MXM-542_	2" x 1.5" Flange (50.8mm x 38.1mm)	2	5.3	87	95	2 HP/145TC	55
		3		96	115		
MXM-543_		1	5.3	115	30	3 HP/182TC	55
		2		87	95		
		3		96	100		
		4		122	160		
MXM-545_		1	13.2	122	110	5 HP/184TC	66
		2		87	95		
		3		96	150		
		4		142	160		

Notes:

1. Rated performance (head/capacity) represents the maximum discharge head/capacity measured with water at 68°F (20°C).
2. Liquid temperature range: 14 to 221°F (-10 to 105° C)
3. Maximum Allowable Working Pressure: 101.5 PSI
3. Slurry: In general, slurries should not be handled. However, a pump with a SiC bearing system, KK, can handle slurries if the hardness is 80Hs or below, with a maximum grain size of 2 MIL (50 microns) and maximum density 5% wt. Contact Iwaki America or your distributor for details.

## 6 Materials of Construction

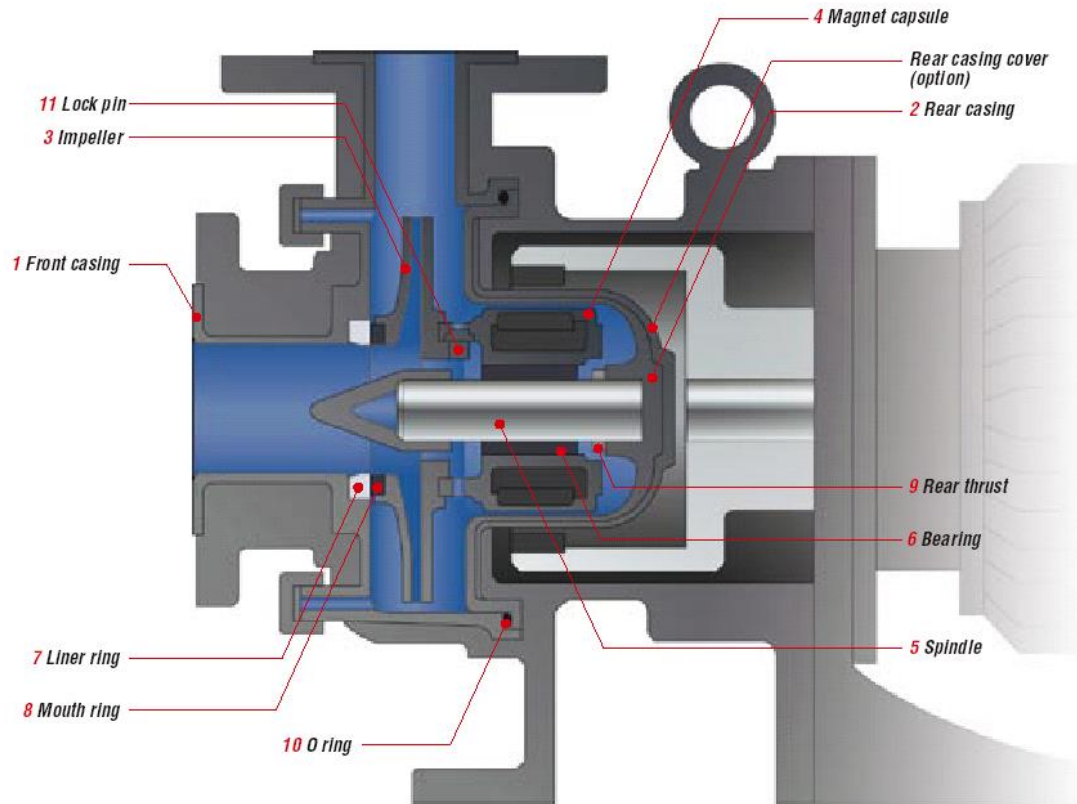

NO.	Item	Materials of Construction		
		CF	FF	KK
1	Front Casing	CFRETFE		
2	Rear Casing			
3	Impeller			
4	Magnet Capsule			
5	Spindle	High Purity Alumina Ceramic		SiC
6	Bearing	High Density Carbon	High Purity Alumina Ceramic	
7	Liner Ring	High Purity Alumina Ceramic		
8	Mouth Ring	PTFE with Filler		
9	Rear Thrust Ring	CFRPFA		
10	O-ring	FKM/EPDM/AFLAS <sup>®</sup> /Dal-el Perfluoro <sup>®</sup>		
11	Impeller Locking Pin	CFRETFE		
12	Rear Casing Support	FRP		



## 7 Handling Instructions

---

### 1. Do not operate the pump dry

The sliding parts used in the MXM Series pumps are lubricated and cooled by the fluid being pumped. Never operate the pump dry or with the valves on the suction side closed. Otherwise, the inside of the pump will be damaged. If the pump is unavoidably or accidentally operated dry, with no obvious damage, allow the pump to cool down for a minimum of one hour before attempting to restart. Do not allow fluid to enter the pump cavity until the pump has cooled down. Sudden or rapid cooling of the pump may cause damage to the ceramic components. A dry run monitoring device (current or power sensor) is recommended for the prevention of damage when dry run operation is likely.

#### "CF" Models

Some MXM models are designed to tolerate brief or intermittent dry run operation. They are identified by the "CF" material code. These models can tolerate dry run conditions for up to one hour. Longer dry run periods, or frequent dry running may result in premature wear of the bushing and shaft. This can rapidly affect the standard clearances of the rotating elements inside the pump. These pumps are designed to reduce the likelihood of cracking resulting from sudden cooling with liquid immediately after dry run operation. However, to ensure that this does not occur, Iwaki America recommends that the pump be allowed to cool for at least 20 minutes after dry running before introducing fluid again.

### 2. Starting and Stopping

Pay close attention to the following points to avoid water hammer upon starting and stopping of pump operation. Extra attention is required when the discharge piping is very long.

#### Starting

Prior to starting the pump, make sure that the power is turned off. Then carry out priming to fill the pump cavity with liquid.

Next, close the valves on the discharge side. Now you can turn the power on and start up the pump. When the pump has reached full speed and line pressure is stable, the discharge valve can be opened to the desired pressure setting.



**Caution!** If the pump is operated with air remaining within the pump cavity, pitting, cracking, or breakage of the bushing and/or thrust collar may occur, causing damage to the pump.

#### Stopping

When stopping the pump, first close the discharge valve gradually. When it is completely closed, turn off the power switch so that the pump stops. Never stop the pump suddenly by quickly closing a valve (i.e., solenoid or hydraulic valves).



**Caution!** Quick valve closure may cause water hammer that can cause severe damage to the pump.

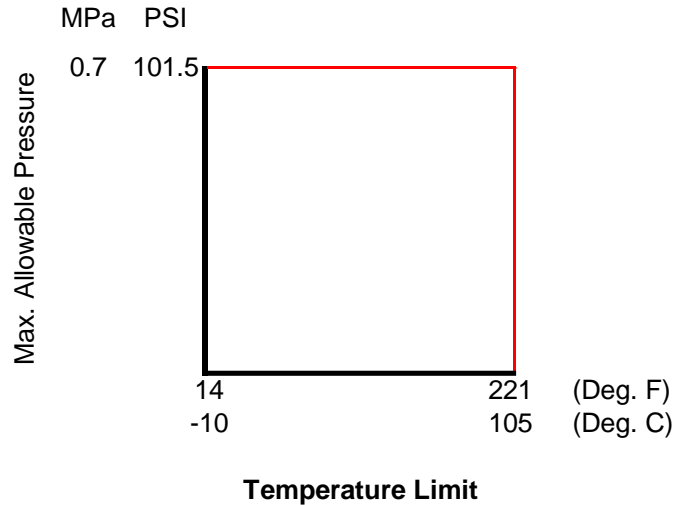

Figure 1

### 3. Maximum system pressure rating

The chart above shows the maximum system pressure rating of each model. Take care that the system pressure does not exceed the maximum pressure rating.

NOTE: Allowable liquid temperature range is 50 - 221° F (10 - 105° C) with Aflas® O-ring.

Ambient Temperature: 32 - 104° F (0 - 40° C)

Ambient Humidity: 35- 85% RH

### 4. Handling of slurry liquid

In general, slurries should not be handled. However, a pump with silicon carbide bearing system (KK material code) can handle slurries if the hardness is 80 Hs or below, with a maximum grain size of 2 MIL (50 microns) and the maximum density 5% wt. Contact Iwaki America or your distributor for details.

### 5. Influence of specific gravity on pump performance

The performance of the MXM pump does not change when pumping fluids of high specific gravity. However, the effect of specific gravity on shaft power and magnet coupling torque requirements must be considered in the selection of the appropriate model for your application.

### 6. Influence of liquid viscosity on pump performance

When pumping a high viscosity liquid, the discharge head and capacity of the pump may be lower than in the case of pure water. The required driving power may also vary and should be verified.

### 7. Allowable liquid viscosity with FF material code

Liquid viscosity should be 1 mPa•S (cP) or more.

### 8. Intermittent operation

Frequent start/stop switching shortens the service life of the pump. Limit the frequency of switching on or off to six times or less per hour.

### 9. Effects of temperature

The pump itself may not suffer a change in performance due to temperature fluctuation. However, the liquid may change in terms of viscosity, vapor pressure, and corrosive properties. Pay special attention to changes in liquid characteristics as a result of temperature fluctuation.

Liquid temperature range: 14 - 221° F (-10 - 105°C)  
Ambient temperature range: 32 - 104° F (0 - 40°C)

Refer to corrosion resistance tables for the recommended temperature range for various types of liquids. In case of any questions, contact Iwaki America or your distributor to determine if operation is feasible.

NOTE: Allowable liquid temperature range is 50 - 221° F (10 - 105° C) with Aflas® O-ring.

**10. Separation of magnet coupling (decoupling)**

If the magnet coupling should disconnect, stop the pump immediately. If operation is continued, the torque rating of the coupling will be permanently reduced.

**11. Operation within range of bell-shaped head/capacity curve**

In the case of a pump which generates a bell-shaped capacity curve in a low-flow range, do not operate the pump in the section where the line ascends. (Refer to the standard performance curve to verify the head/capacity). If the rightward ascending section of the head/capacity curve is part of the pump operation specifications, design the piping by observing the following points:

1. The discharge piping should have no water tank or air trap,
2. The discharge quantity must be adjusted by a valve that is installed close to the discharge port of the pump.

## 8 Installation, Piping, and Wiring

---

### ■ *Installation Position*

1. Install the pump as close to the suction tank as possible (flooded suction). If the suction port of the pump is positioned higher than the suction tank (suction lift), be sure to arrange a foot valve in the suction pipe. The lifting capability depends upon the liquid properties, temperature, and length of suction piping. For details, consult Iwaki America or your distributor.
2. The pump can be installed indoors or outdoors. However, there should be sufficient space around the pump to enable efficient and easy maintenance.

### ■ *Installation*

1. The pump anchoring area must be greater than the area of the pump baseplate. If the anchoring area is not large enough, the baseplate may be damaged due to the concentration of loads placed on it.
2. Set the pump baseplate on a concrete foundation and fasten the anchor bolts tightly to prevent the pump from vibrating during operation. A sturdy metal (or reinforced) skid or platform is also an acceptable mounting surface.
3. Insert a spacer between the concrete surface and the bottom of the base to level the pump horizontally. Next put a level on the discharge flange surface to adjust the pump horizontally in the direction of the pump shaft. Also adjust the direction vertical to the pump shaft at the same time by placing a level on the suction flange surface. Pour cement mortar into the anchor bolt holes after leveling has been completed. When the cement mortar is hardened, fasten the anchor bolt nuts firmly. [Fig. 2]
4. In case there is influence of motor vibration during operation (e.g. sympathetic vibration with piping), an expansion joint should be provided between the pump and the piping before installation. Otherwise, pipes and gauges may be damaged.

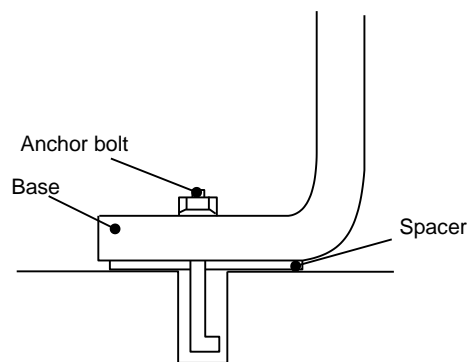

Figure 2

## ■ **Piping**

1. Discharge pipe (use a support  
To keep the pump free from the  
load of the pipe)
  2. Gate valve
  3. Check valve
  4. Pressure gauge
  5. Motor
  6. Pump
  7. Priming pump
  8. Gate valve
  9. Drain valve
  10. Compound gauge
  11. Suction pipe (shortest horizontal  
section with an ascending gradient  
toward the pump)
  12. Pipe support
  13. Pump drain
  14. Suction pipe
  15. Suction pipe stabilizer brace  
(used if suction pipe is particularly  
long)
  16. Foot valve
  17. 1.5D\* or more
  18. 18 inches or more
  19. 1-1.5D\* or more (if sediment  
accumulates easily)
  20. Suction tank
  21. Screen
  22. Short pipe
- \* Pipe diameter

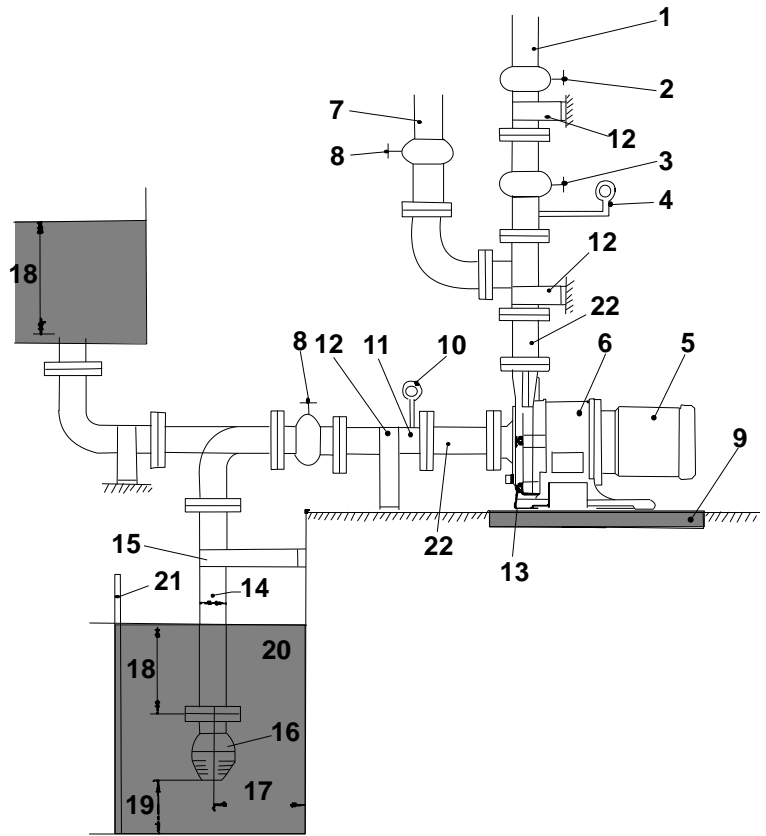

Figure 3

## ■ **Suction Piping**

1. The suction pipe should employ the flooded suction method if possible. The shortest pipe possible, with the minimum number of bends, should be designed. Arrange a proper support on the suction pipe so that the load and the thermal stress of the pipe itself are not applied to the pump.
2. Attach the coupling on the suction pipe carefully, so that no air enters the line. The presence of air in the suction pipe may prevent priming of the pump.
3. Avoid installations with poor suction conditions (e.g. vacuum in suction tank, large suction head or long suction piping). NPSHa should always be at least 2 feet greater than NPSHr. For NPSHr values, refer to the standard performance curve for your pump model or contact Iwaki America or your distributor.
4. When using a bend on the suction side, install a straight pipe which is more than 20 inches long or 10 times as long as the suction port diameter before the suction port of the pump. Use the largest possible radius of curvature for the bend.

5. Do not allow any projection where air may be trapped along the suction pipe. The suction pipe should have an ascending gradient toward the pump.
6. If the diameters of the pump suction port and the suction pipe are different, use an eccentric reducer pipe. Connect the eccentric reducer pipe such that the upper part of it is level. **Never use a suction pipe with a diameter smaller than that of the pump's suction port.**
7. When using the flooded suction method, the suction pipe should be given a slight ascending gradient toward the pump so that no air pocket is created on the suction side.
8. The end of the suction pipe should be located 18 inches or more below the surface of the liquid.
9. A screen should be provided at the inlet of the suction tank to prevent the entrance of foreign matter into the suction pipe. Foreign matter may cause malfunctioning of and/or damage to the pump. The end of the suction pipe should be a least 1- 1.5D from the bottom of the suction tank. (D=Diameter of suction pipe).
10. When employing the suction lift method, install a foot valve on the suction pipe.
11. When using the flooded suction method, it is recommended that a gate valve be installed on the suction pipe for easier overhaul inspection of the pump. Since this valve is used only in the overhaul inspection of the pump, keep it fully opened during normal pump operation.
12. Pay close attention to the lowest level of the liquid in the suction tank to avoid vortexing, air entrapment and associated suction piping concerns.

The inflow pipe into the suction tank should be distanced from the suction pipe and positioned below the liquid surface as a means of preventing air entrainment to the suction pipe. If air bubbles are generated in the suction tank, install a baffle.

13. It is recommended that a vacuum/pressure gauge be installed on the suction piping approximately 6 pipe diameters from the pump suction port.

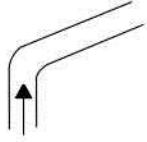
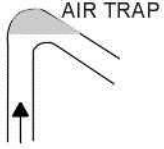
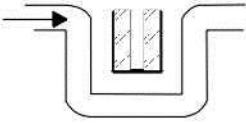
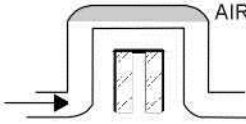
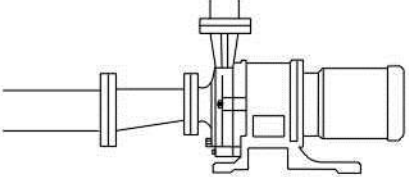
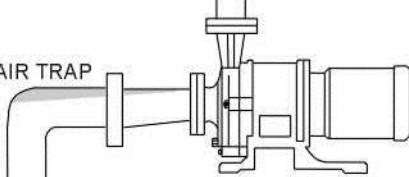
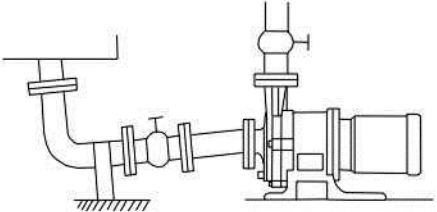
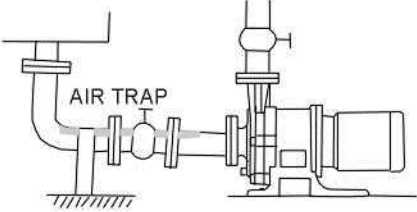
GOOD CONDITIONS	UNACCEPTABLE CONDITIONS
	
	
	
	

■ **Discharge Piping**

1. Use proper pipe supports so that the weight of the piping does not load the pump nozzle.
2. If a method other than flooded suction is used, install a special pipe for priming.
3. If the piping is very long, its diameter should be determined by calculating the piping resistance. Otherwise, the specified performance may not be obtained due to increased piping resistance.
4. A check valve should be installed if any of the following conditions exists in the piping:
  - The discharge piping is very long.
  - The discharge head is 50 feet or more.
  - The end of the discharge pipe is located 30 feet higher than the surface of the suction tank.
  - Several pumps are connected in parallel with the same piping.
5. The installation of a gate valve on the discharge pipe is recommended for the adjustment of discharge quantity and for the prevention of motor overload. When installing both a check valve and a gate valve, the check valve should be positioned between the pump and the gate valve.

6. A pressure gauge must be installed on the discharge piping, prior to the gate valve.
7. An air bleeding valve should be installed if the discharge pipe is very long in the horizontal direction.
8. A drain valve should be installed for the drainage of liquid if there is a chance that the liquid in the discharge pipe will freeze.

■ **Wiring**

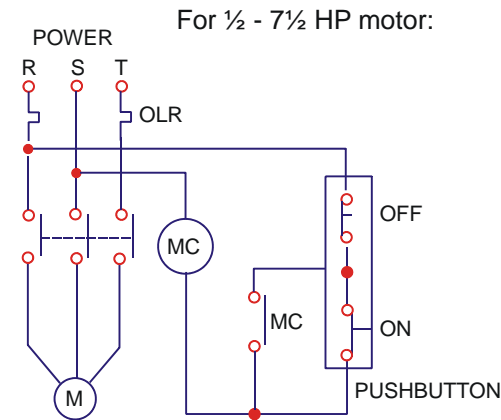

M     MOTOR  
 MC    ELECTROMAGNETIC SWITCH  
 ON    ] PUSH BUTTON  
 OFF   ]  
 OLR   OVERLOAD RELAY

Figure 5

Use appropriate wiring materials, follow the instruction manual for the motor and abide by the local and national electrical codes. In addition, follow the instructions given below:

1. Use a motor contactor that conforms to the specifications (voltage, current, etc.) of the pump motor.
2. If the pump is installed outdoors, use waterproof wiring to protect the switches from rainwater and moisture.
3. The motor contactor and push button should be installed a reasonable distance from the pump. Refer to the wiring examples shown above. (These examples do not include the installation of a dry run prevention device. Follow the instruction manual of the dry run prevention device when installing it.)



## 9 Operation

---

### ■ **Notes on Operation**

1. Never operate the pump with the suction valve (gate valve) closed. Otherwise, the internal bushing of the pump will be damaged.
2. In the event of cavitation, stop the pump immediately.
3. If the magnet coupling disconnects, stop the pump immediately. The torque rating of the magnet coupling will be reduced if operation is continued with the coupling disconnected.
4. Liquid temperature fluctuation should not exceed 144<sup>o</sup> F (62°C) when starting, stopping, and operating the pump.
5. Be sure to close the discharge valve completely prior to start-up in order to prevent water hammer.
6. The pump should never be operated with the discharge valve closed for longer than one minute. A resulting rise in temperature of liquid within the pump may cause damage.

In the event of a service power failure, turn off the power switch immediately and close the discharge valve.

### ■ **Start-Up Preparation**

When operating the pump for the first time after installation, and when restarting operation after a long interval, prepare for operation as described below.

1. Thoroughly clean the inside of the piping and pump.
2. Tighten the union fittings or flange connecting bolts and base plate installation bolts. Check the torque of the bolts that couple the front casing and the bracket together. Proper torque is 18 Ft-lbs (24.5 N·m).
3. Close the cocks of any pressure or vacuum gauges to prevent damage from sudden pressure changes. Open only when taking measurements.
4. Fully open the suction gate valve and partly open the discharge valve. Discharge valve may be adjusted after completion of priming and start-up process.
5. Use a screwdriver to rotate the motor fan and check that the fan rotates smoothly. This also purges any residual air from in and around the impeller.
6. If using flooded suction, measure the pressure in the suction pipe to verify that the pump is filled with liquid.
7. Run the motor momentarily to check the direction of motor rotation. The motor should run in the direction indicated by the arrow cast on the pump casing. If the direction is reversed, exchange two wires of the three-phase power wires.

Note: All Iwaki America MXM Series pumps rotate counter-clockwise when looking at the suction port of the pump. Naturally, from the motor fan side, this would be viewed as clockwise.

■ **Starting Operation Steps**

Pump operation is detailed below.

Operation Step	Notes
1. Verify valve position	Suction valve should be fully open, discharge valve fully closed.
2. Check that the pump is filled with liquid.	If the pump is not full of liquid, fill it according to steps 5 & 6 of “Startup Preparation.”
3. Turn motor switch ON momentarily to check for correct direction of pump rotation	Note the arrow direction on the casing to confirm the direction of rotation (clockwise when viewed from the motor fan side).
Flow rate adjustment: Once total discharge pressure is increased to shut off pressure, open discharge valve gradually to set discharge pressure to desired specification.	Open valve slowly, paying attention to the motor current draw to prevent it from being overloaded through excessive opening of the valve.
Pump should be operated at a minimum flow rate of:	
Model: MXM-22/44	2.5 GPM (10 LPM)
Model: MXM-542	5.3 GPM (20 LPM)
Model: MXM-543	5.3 GPM (20 LPM)
Model: MXM-545	13.2 GPM (50 LPM)
In case of automatic control, close discharge valve when starting pump and gradually open the discharge valve thereafter. Do not operate the pump with the discharge valve closed for more than one minute.	
Points to be observed during operation: If the pump enters continuous operation condition, check flow meter and confirm that pump operation meets specifications. If flow meter is unavailable, check values of discharge pressure, suction pressure and current in relation to piping resistance.	

■ **Stopping Operation Steps**

Operation Step	Notes
1. Close discharge valve gradually.	 Caution! Do not cause sudden closure by using solenoid valve, etc. Pump may be damaged by water hammer.
2. Stop motor.	Observe that the motor stops rotating slowly and smoothly. If not, check inside of pump.
Points to be observed when stopping: If pump operation is stopped in cold weather, liquid inside the pump cavity may freeze and damage the pump. Be sure to drain liquid completely. In case of short term shut down, that does not allow removal of liquid, use band heater to prevent liquid from freezing. In case of service power failure, turn power switch OFF and close discharge valve.	

## 10 Maintenance and Inspection

---

■ **Daily Inspection**

1. Check that the pump operates smoothly, without generating abnormal sounds or vibration.
2. Check the level of the liquid in the suction tank, and the suction pressure.
3. Compare the discharge pressure and current measured during operation with the specifications indicated on the motor and pump nameplates to verify normal pump load.

Note that the indicated value of the pressure gauge varies in proportion to the specific gravity of the liquid.

Note: The valve of the pressure gauge or vacuum gauge should be opened only when measurements are recorded. It must be closed after completion of each measurement. If the valve remains open during operation, the gauge mechanism may be affected by abnormal pressure caused by water hammer.

4. If a spare pump is included in the installation, keep it ready for use by operating it from time to time.

■ **Periodic Inspection**

1. To ensure efficient, smooth operation of the pump, carry out periodic inspection by following the procedure described below. Inspection records should be maintained.
2. When carrying out an overhaul inspection, handle the internal bushings and plastic components most carefully. Since the outer drive magnet and inner magnet capsule are very powerful, handle these components with caution. Take care not to trap hands and fingers between the magnets and metal objects. Also avoid positioning the magnets near any electronic device that could be affected by a strong magnetic field (i.e.. ATM cards or computer disks).

Inspection Interval	Part	Inspection Points	Operator Action
Every 6 months	Outer magnet assembly	<ul style="list-style-type: none"> <li>▪ Check for scoring</li> <li>▪ Is magnet mounted normally? Is hexagonal socket set screw loose?</li> <li>▪ Is inner perimeter of magnet &amp; motor shaft concentric?</li> </ul>	<ul style="list-style-type: none"> <li>▪ Contact distributor if any abnormality is found.</li> <li>▪ Reinstall magnet on motor shaft and fasten hexagonal socket set screws.</li> <li>▪ Re-tighten or replace hexagonal socket set screws.</li> </ul>
Every 3 months	Containment shell	<ul style="list-style-type: none"> <li>▪ Check for scoring on inner diameter.</li> <li>▪ Are there any cracks in liquid-containing section?</li> <li>▪ Wear of thrust collar?</li> <li>▪ Stain in containment shell?</li> </ul>	<ul style="list-style-type: none"> <li>▪ Contact distributor if abnormality is observed.</li> <li>▪ Replace if abnormality is observed.</li> <li>▪ Replace if abnormality is observed</li> <li>▪ Clean.</li> </ul>

Inspection Interval	Part		Inspection Points	Operator Action
Every 3 months	Impeller	Inner magnet assy	<ul style="list-style-type: none"> <li>▪ Is there scoring on rear face or cylindrical body?</li> <li>▪ Are there any cracks in the plastic of the rear section or cylindrical body?</li> <li>▪ Bushing wear.</li> </ul>	<ul style="list-style-type: none"> <li>▪ Contact distributor if any abnormality is observed.</li> <li>▪ Contact distributor if any abnormality is observed</li> <li>▪ Replace if abnormality is observed. (See Tolerance chart)</li> </ul>
		Impeller	<ul style="list-style-type: none"> <li>▪ Are there any cracks?</li> <li>▪ Are there any cavitation marks?</li> <li>▪ Stain or clogging inside impeller?</li> <li>▪ Dimensional change of impeller?</li> </ul>	<ul style="list-style-type: none"> <li>▪ Replace if abnormality is observed.</li> <li>▪ Eliminate cause.</li> <li>▪ Clean.</li> <li>▪ Replace if abnormality is observed.</li> </ul>
Every 3 months	Front casing liner		<ul style="list-style-type: none"> <li>▪ Stain in liquid-contacting section?</li> <li>▪ Are there any cracks?</li> <li>▪ Wear or crack on inboard thrust collar?</li> <li>▪ Expansion or wear of O-ring?</li> <li>▪ Scoring on inner surface?</li> </ul>	<ul style="list-style-type: none"> <li>▪ Clean</li> <li>▪ Replace if abnormality is observed.</li> <li>▪ Contact distributor if abnormality is observed.</li> <li>▪ Replace if part is damaged.</li> <li>▪ Contact distributor if abnormality is observed.</li> </ul>
	Shaft		<ul style="list-style-type: none"> <li>▪ Are there any cracks?</li> <li>▪ Wear on surface?</li> </ul>	<ul style="list-style-type: none"> <li>▪ Replace if abnormality is observed.</li> <li>▪ Replace if wear limit is exceeded.</li> </ul>

## ■ Replacement Tolerance Chart

Dimensions in inches (mm)

Model		MXM-542, 543, 545		MXM-220, 221, 441, 442	
(N)= New	(W) = Worn	N	W	N	W
(A) Bushing ID *		0.944 in. 24 mm	0.984 in. 25 mm	0.709 in. 18 mm	0.748 in. 19 mm
(B) Shaft OD*		0.944 in. 24 mm	0.905 in. 23 mm	0.709 in. 18 mm	0.669 in. 17 mm
(C) Thickness of mouth ring **		0.295 in. 7.5 mm	0.216 in. 5.5 mm	0.295 in. 7.5 mm	0.216 in. 5.5 mm

- \* If the difference between Bushing ID and shaft OD exceeds 0.039 in. (1mm), either the bushing or the shaft, whichever has greater wear, should be replaced regardless of the values in the above table. In case of a ceramic bushing type pump (FF material code), the shaft and the bushing should be replaced simultaneously.

Initial wear may appear in the sliding part in the first stages of operation. This should not be mistaken for an abnormal condition.

- \*\* The step between the surfaces of the mouth ring and the impeller upon shipment is 0.079 in. (2mm). Replacing the mouth ring is recommended before this step is reduced to 0 in. [Fig. 6]

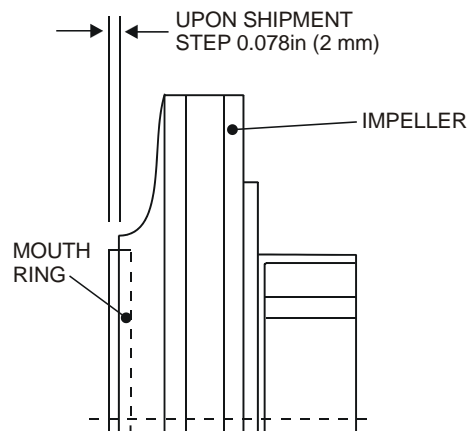

Figure 6

# 11 Troubleshooting

Problem	Symptom on Pump		Cause	Inspection & Countermeasures	
	Discharge valve closed	Discharge valve open			
Liquid is not pumped		Pressure gauge & vacuum gauge indicate zero	<ul style="list-style-type: none"> <li>▪ Insufficient priming</li> <li>▪ Dry run operation</li> </ul>	<ul style="list-style-type: none"> <li><input type="checkbox"/> Stop pump, feed priming liquid &amp; restart</li> <li><input type="checkbox"/> Replace strainer</li> </ul>	
	Liquid level drops immediately when priming		<ul style="list-style-type: none"> <li>▪ Foot valve clogged with foreign matter</li> </ul>	<ul style="list-style-type: none"> <li><input type="checkbox"/> Check whether seat is clogged</li> <li><input type="checkbox"/> Check that connection flange in suction piping is sealed airtight</li> </ul>	
	Liquid level drops if discharge valve is opened after starting operation		Pressure & vacuum gauge needles swing but return to zero immediately	<ul style="list-style-type: none"> <li>▪ Air enters thru suction pipe or gasket section</li> </ul>	<ul style="list-style-type: none"> <li><input type="checkbox"/> Check whether suction liquid level is abnormally low</li> <li><input type="checkbox"/> Stop pump &amp; use a screwdriver to check for easy &amp; smooth rotation of motor fan.</li> </ul>
				<ul style="list-style-type: none"> <li>▪ Magnet coupling is disconnected (de-coupled)</li> </ul>	<ul style="list-style-type: none"> <li><input type="checkbox"/> Measure current level to check for low reading</li> <li><input type="checkbox"/> Check for foreign matter inside pump cavity</li> <li><input type="checkbox"/> Check whether voltage level is normal</li> <li><input type="checkbox"/> Replace outer magnet and/or inner magnet assembly</li> <li><input type="checkbox"/> Confirm fluid specific gravity &amp; magnet rating, determine if S.G. exceeds magnet rating</li> </ul>
				<ul style="list-style-type: none"> <li>▪ RPM of pump is insufficient</li> <li>▪ Pump rotation is reversed</li> </ul>	<ul style="list-style-type: none"> <li><input type="checkbox"/> Check wiring &amp; motor and fix as necessary</li> <li><input type="checkbox"/> Correct motor wiring</li> </ul>
Discharge quantity is small.	Needles of pressure & vacuum gauges indicate normal values.	Vacuum gauge indicates high value.	<ul style="list-style-type: none"> <li>▪ Strainer is clogged with foreign matter &amp; liquid passage is blocked.</li> </ul>	<ul style="list-style-type: none"> <li><input type="checkbox"/> Remove foreign matter in strainer.</li> </ul>	
		Vacuum gauge indicates abnormally high value.	<ul style="list-style-type: none"> <li>▪ Air is trapped in suction pipe.</li> <li>▪ Inlet section of impeller unit is clogged with foreign matter.</li> </ul>	<ul style="list-style-type: none"> <li><input type="checkbox"/> Inspect installation of suction pipe &amp; modify as necessary.</li> <li><input type="checkbox"/> Partially disassemble unit &amp; remove foreign matter.</li> </ul>	
		Pressure & vacuum gauges fluctuate.	<ul style="list-style-type: none"> <li>▪ Air enters via suction pipe or gasket section.</li> <li>▪ Discharge side of pump is clogged with foreign matter.</li> </ul>	<ul style="list-style-type: none"> <li><input type="checkbox"/> Check flange gaskets of suction pipe &amp; tighten.</li> <li><input type="checkbox"/> Remove foreign matter or scale inside of piping.</li> </ul>	
		Vacuum gauge reads high while pressure gauge indicates normal value.	<ul style="list-style-type: none"> <li>▪ Air pocket or resistance in suction pipe.</li> </ul>	<ul style="list-style-type: none"> <li><input type="checkbox"/> Inspect suction piping installation &amp; make corrective adjustments.</li> </ul>	
		Pressure gauge reads high while vacuum gauge indicates normal value.	<ul style="list-style-type: none"> <li>▪ Discharge piping section causing high resistance or actual head &amp; loss of head is too high.</li> </ul>	<ul style="list-style-type: none"> <li><input type="checkbox"/> Check actual head &amp; piping loss of discharge pipe &amp; take necessary measures.</li> </ul>	

Problem	Symptom on Pump		Cause	Inspection & Countermeasures
	Discharge valve closed	Discharge valve open		
Discharge quantity is small	Pressure gauge reads low & vacuum gauge reads very low	Pressure & vacuum gauges indicate low values	<ul style="list-style-type: none"> <li>▪ Rotating direction of pump/motor is reversed.</li> </ul>	<ul style="list-style-type: none"> <li><input type="checkbox"/> Correct motor wiring to reverse rotation (clockwise when viewed from motor side)</li> </ul>
Motor overheats			<ul style="list-style-type: none"> <li>▪ Insufficient voltage</li> <li>▪ Overload</li> <li>▪ Ambient temperature is high.</li> </ul>	<ul style="list-style-type: none"> <li><input type="checkbox"/> Check whether voltage &amp; frequency levels are adequate.</li> <li><input type="checkbox"/> Check whether specific gravity &amp; viscosity of liquid are above spec. Stop pump &amp; use screwdriver to check whether motor fan rotates easily &amp; smoothly.</li> <li><input type="checkbox"/> Improve air ventiation.</li> </ul>
Discharge quantity is suddenly lowered.		Vacuum gauge reads high	<ul style="list-style-type: none"> <li>▪ Strainer is clogged with foreign matter</li> </ul>	<ul style="list-style-type: none"> <li><input type="checkbox"/> Remove foreign matter.</li> </ul>



## 12 Parts Description and Exploded View

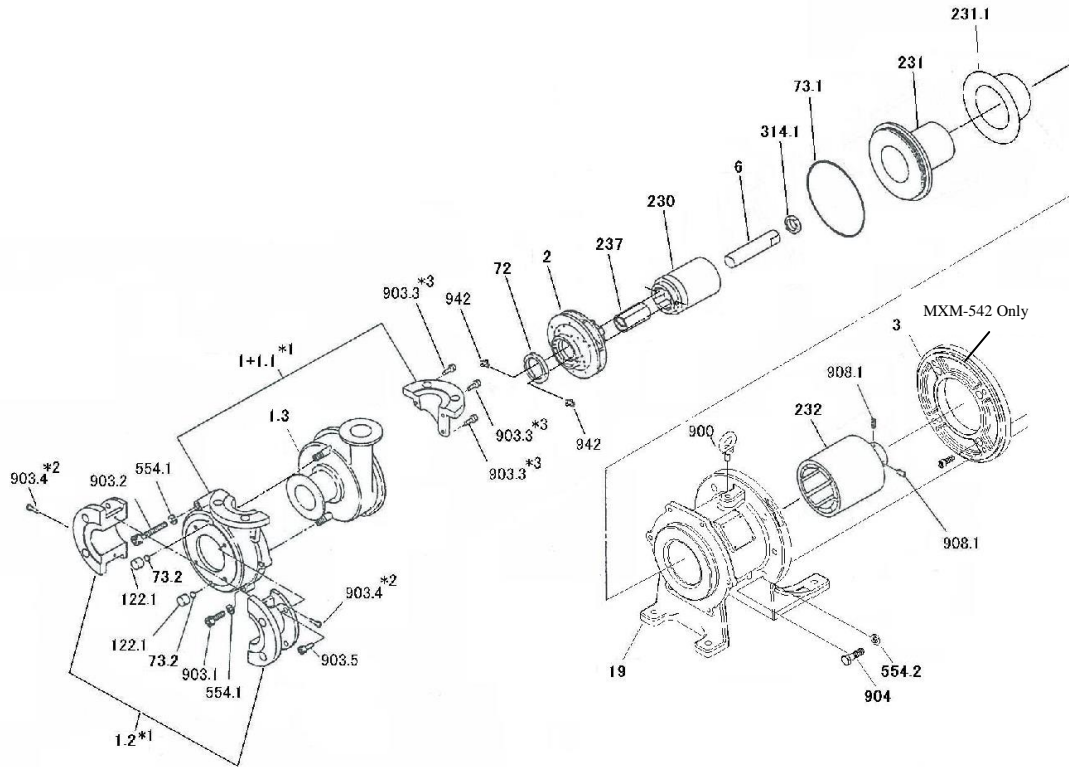

No.	Description	Qty	No.	Description		Qty
1 + 1.1	Cover A/B <sup>1</sup>	1	314.1	Rear Thrust Collar		1
1.2	Cover C <sup>2</sup>	1	554.1	Spring Washer	M10	6
1.3	Front Casing Liner	1	900	Eye Bolt	M10	1
2	Impeller	1	903.1	Hex Socket Bolt	M10 x 40	5
6	Spindle	1	903.2	Hex Socket Bolt	M10 x 80	1
19	Frame	1	903.3	Hex Socket Bolt <sup>3</sup>	M6 x 18	3
72	Mouth Ring	1	903.4	Hex Socket Bolt <sup>3</sup>	M8 x 20	2
73.1	O-ring	1	903.5	Hex Socket Bolt	M8 x 15	4
73.2	Gasket	2	908.1	Hex Socket Set Screw <sup>4</sup>	M8 x 10	2
122.1	Drain Cap	2	942	Locking Pins		2
230	Magnet Capsule Assy.	1	330	Motor Adaptor, MXM-542 Only		1
231	Rear Casing	1	904	Hex Head Bolt	M12 x 40	4
231.1	Rear Casing Cover	1		MXM-542 Only		
232	Drive Magnet	1	554.2	Spring Washer	M12	4
237	Bearing	1		MXM-542 Only		

1. The two pieces make a single set.
2. Cover C is divided into right & left parts. The two make a single set.
3. Hex socket bolts included with cover sets.
4. Hex socket bolts Included with Item# 232, drive magnet.

## 13 Disassembly and Assembly of Pump



### Caution!

Since the magnets used in the pump are powerful, be careful not to catch your fingers or hand between them during disassembly or assembly. Also, keep the magnet unit away from any electronic device that could be affected by a strong magnetic field.

Prior to servicing, the suction and discharge valves must be closed. The piping and the pump often retain some liquid. It is recommended the piping and pump cavity be drained prior to servicing.

If dangerous liquid is used, wear protection and flush pump with clean water or decontaminant prior to service.

Make sure power to motor is OFF.

### ■ Disassembly

1. Remove the drain and vent caps (122.1) to discharge the liquid from the pump. Flush the inside of the pump with a neutralizing fluid. [Fig. 7]
2. Remove the hex head or socket bolts (903.1 & 903.2) and pull the front casing straight forward to detach from the frame (19). [Fig. 8 & 9] Be careful not to damage the spindle when removing the front casing. The spindle may come off with the front casing. If this happens, take care to no lose the rear thrust collar (314.1).

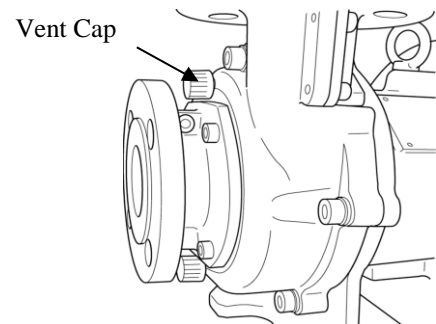

Figure 7



**Caution!** Strong impacts may crack the shaft or liner. Do not hit them with a tool.

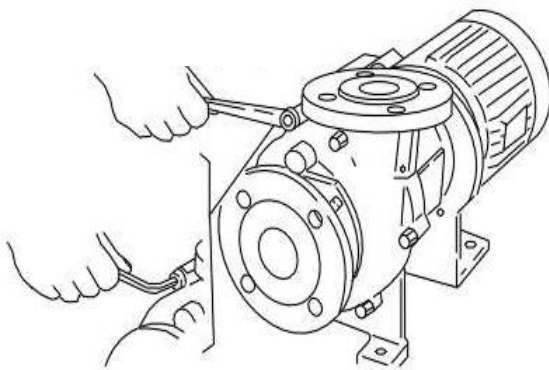

Figure 8

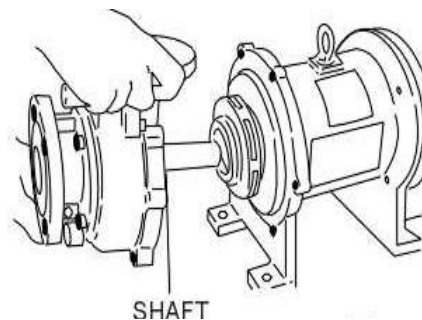

Figure 9

- Remove impeller (2) and inner magnet assembly (230) from the containment shell (231) by drawing it forward. Be careful not to scratch the surface of each part. Since the inner magnet assembly is strongly magnetized, store it in a place free of metal pieces. Handle the front casing liner (1.3), inner magnet assembly and impeller with extra care so as not to scratch the bushing and sealing surfaces. [Fig. 10]

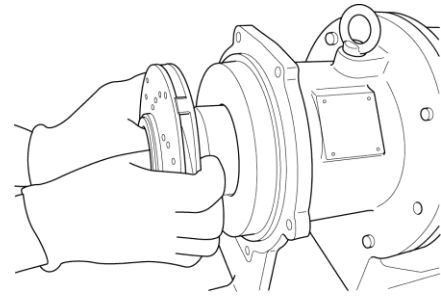

Figure 10

- To remove rear casing, insert a flat head screw driver into the periphery of the rear casing and slightly twist the screw driver. If the spindle remains in the front casing liner, remove it from the front casing. [Fig. 11]
- Remove spindle from rear casing, while firmly grabbing spindle, simultaneously pull and wiggle the spindle. If necessary, submerge spindle where fixed to casing in hot water (194° F / 90° C) for approx. 5 minutes.

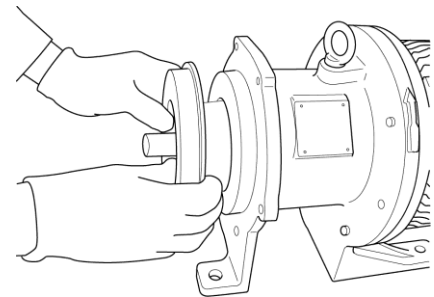

Figure 11

- To disassemble impeller and magnet capsule assembly, turn the locking pins counter clockwise 90 degrees using a slotted screw driver and then push it towards the inside of the impeller. [Fig. 12] If it is hard to push it out, slightly tap the end of the screwdriver handle.

If the screw- driver cannot be used because the groove of the pin was crushed, turn the pin from inside of magnet capsule using hex wrench. [Fig. 13] When doing so, turn the wrench clockwise. After turning the pin, push it in from the outside using a screwdriver or drive pin.

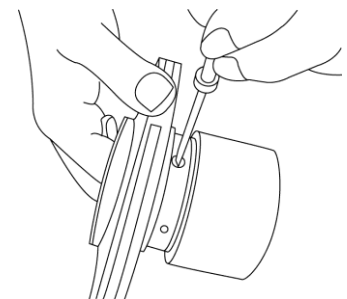

Figure 12

After the two locking pins are removed, remove the impeller from the magnet capsule by slightly tapping the periphery of the impeller with a plastic hammer. If it is hard to remove, warm it with hot water (approx. 194° F / 90° C) for five minutes and remove it by slightly tapping the impeller as described above. Pay attention to not burn yourself. If impeller is forced from magnet capsule before the locking pins are removed, the impeller and magnet capsule may be damaged.

- Remove the drive magnet assembly (232). Stand the motor up and remove two M8 hex head socket set screws (908.1) from the access hole in the frame (19). Insert a screwdriver and apply it to the boss (lower portion) of the outer magnet assembly and pull or lever the unit upwards. [Fig. 14] Store the magnet assembly in a proper place so that metal pieces, etc. are attracted to it.



**Caution!** Do not strike outer magnet assembly. Direct impact may loosen magnet strips or damage the motor bearings.

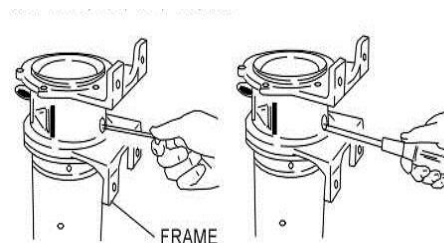

Figure 14

the  
the

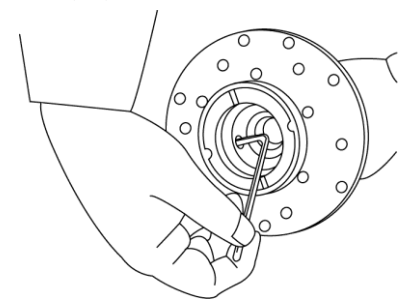

Figure 13

## 8. Replacement of Bushing, Mouth Ring

### Bushing

1. Warm the inner magnet assembly (230) in hot water at 194° F (90° C) for approximately 5 minutes. Then using a hand (arbor) press, remove the bushing (237) by pressing the replacement jig from the front end of the inner magnet assembly. [ Fig. 15] (Consult Iwaki America for jig specifications).

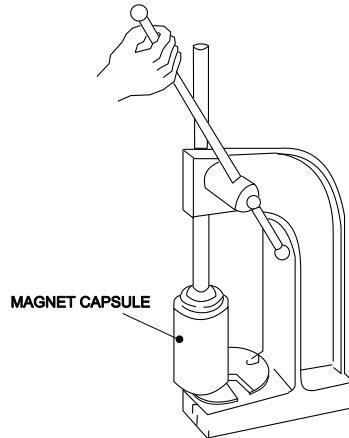

Figure 15

\* Bearing is pressed in from far end of magnet capsule.

2. Align the new bushing to the back end of the inner magnet assembly.\* Use the replacement jig to press the bushing into the inner magnet with the hand (arbor) press. (If the inner magnet is cold, warm it as in step 1 above prior to pressing in the bushing).
3. After pressing in the new bushing, ensure that it is seated at the top and protrudes from the bottom of the inner magnet assembly.

### Mouth Ring:

1. Heat weld tabs that are folded over mouth ring on impeller (2).
2. Remove the outboard thrust collar by applying a screwdriver to the bottom of it and lift upwards.
3. Place a new outboard thrust collar into the impeller by aligning the recessed areas of the outboard thrust collar with the mating surfaces of the impeller and press using the hand (arbor) press. Ensure that the outboard thrust collar is completely seated against the recess in the impeller.

### Front Casing Liner:

1. Remove the drain and vent caps (121.1).
2. Remove the four hex socket bolts (903.5).
3. Remove the two hex socket bolts (90.4) and separate Cover C (1.2) [ Fig. 16].  
\* Note: Cover C is divided into two halves. The two make a single set.
4. Remove the three hex socket bolts (903.3) and separate Cover A (1+1.1).  
\*Note: Cover A is divided into two halves. The two pieces make a single set.

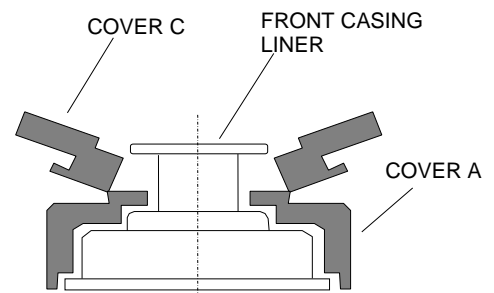

Figure 16

Detach the front casing liner from Cover A. If this is difficult due to corrosion or rust on the cover, use a resin hammer and gently tap the suction port of the front casing. (This step completes disassembly of the front casing liner).

\*Note: Cover A should always be stored as a single unit.

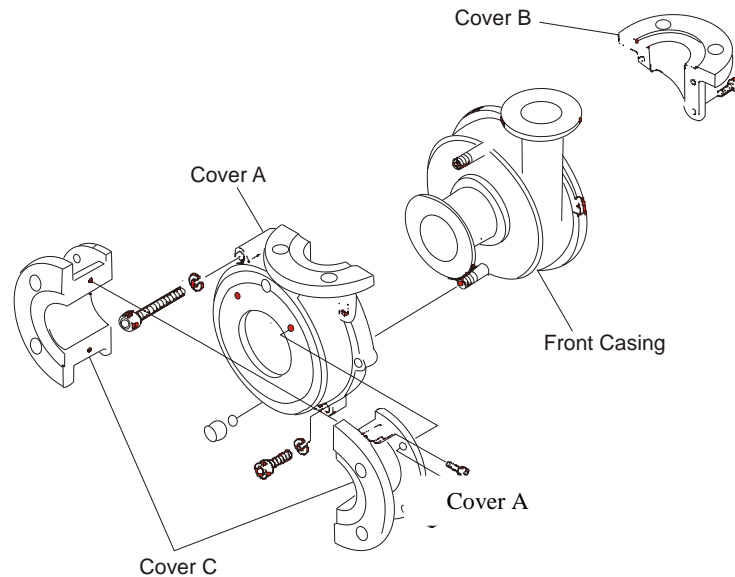

Figure 17

5. Align and install a new front casing liner into cover A, paying attention to the drain port and locating tabs. [Fig. 17] If the front casing liner is difficult to attach, tap it gently with a resin hammer. \*Note: Tapping the back portion of the front casing liner may cause sealing difficulty during reassembly.
6. Attach and temporarily secure both halves of Cover A with the hex socket bolts (903.3).
7. Attach and temporarily secure the two halves of Cover C (1.2) to Cover A (1 + 1.1) with the hex socket bolts (17). Tap the two parts gently in a slanted direction from the front casing liner suction port. [Fig. 16]
8. Align Covers A and C and secure all hex socket bolts tightly.
9. Insert gasket (73.2) into the vent and drain caps (122.1) prior to installing them.

## ■ Reassembly

Reassemble the pump by reversing the order of disassembly. Refer to the exploded view diagram on page 23 for parts and locations. Pay attention to the following points:

1. Replacement of o-ring and gasket  
When reassembling pump, always replace the o-ring and gaskets. In addition, confirm that the o-ring and gaskets are not twisted or pinched by another part.  
The sealing section should be cleaned free of dust or scratches before installation.
2. Fastening of bolts  
Fasten the front casing bolts in a diagonal order, applying an equal torque to each.

Model	Type	Fastening Torque			Size of Bolt
		Nm	Kgf/cm	Lbf/in	
220, 221	Hex socket head bolt	12.5	127	111	M8
441, 442, 542, 543, 545		24.5	250	217	M10 x 80, M10 x 40

3. Ceramic type  
For pumps containing a ceramic bushing (FF), apply a small film of fluorocarbon grease on the inside diameter of the bearing and spindle. This will prevent premature wear during initial start-up.
4. Use the following table [Fig. 18] for correct placement of the drive magnet.

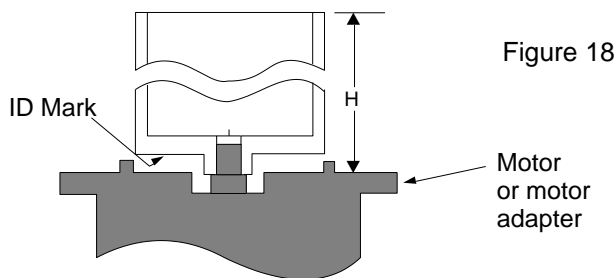

Figure 18

Model	Height - H in (mm)
MXM-221/222	4.69" (119)
MXM-441	4.55" (116)
MXM-442	4.09" (104)
MXM-542	5.98" (152)
MXM-543 & 545	6.17" (157)

5. Mount and bolt the frame (19) to the motor. . (Check orientation/label)
6. Mount and secure the drive magnet (232) to the motor shaft. [Fig. 18] \*Note: Use Loctite 242 (thread locker) and torque the set screws to 8.9 ft-lbs (12 Nm).
7. Mount the impeller to the magnet capsule.  
The mating part of the magnet capsule has two holes. The larger hole is for the lock pin (stepped hole on the outside is 6 mm dia and the inside is 12mm dia) and a smaller hole (3mm dia.) is for cooling purposes. The U-shaped hole of the impeller and smaller hole (3 mm dia) of magnet capsule are also for cooling purposes. Insert the impeller into the magnet capsule slowly by positioning the two holes together. If it is hard to insert them, warm the magnet capsule only with hot water (176° F 90 deg. C) for five minutes. [Fig. 19]

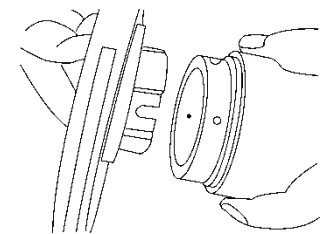

Figure 19

After the impeller is inserted (press-fit), insert the lock pins from the inside and then tighten the pin by turning it clockwise 90 degrees from outside with a slotted screwdriver. You will feel a snap when it is fixed securely.

If the groove for a slotted screwdriver is deformed, the pin can be locked from the inside with a 4mm hex wrench. Turn the wrench counter clockwise. [Fig. 20]

- Place rear thrust collar (314.1) on shaft (6) and press shaft into rear casing. Make sure the anti-rotational flat on the spindle aligns with the flat edge in rear casing. Place rear casing (231) with spindle (6) and rear thrust collar (231) on pump frame (19).
- Place assembled impeller (2) and magnet capsule assembly (230) in rear casing (231).



**Caution**

Magnet force is very strong. Apply plastic or wooden spacers between the rear casing and frame to absorb any slack. [Fig. 21] Be careful not to pinch your fingers.

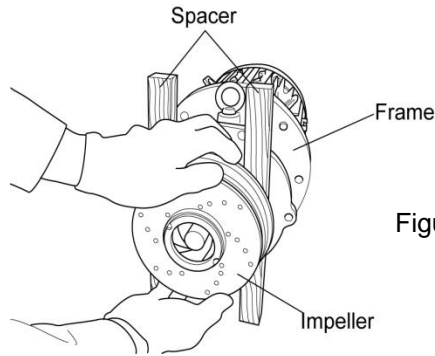

Figure 21

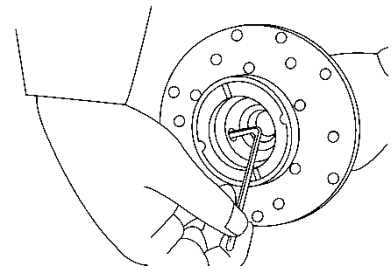
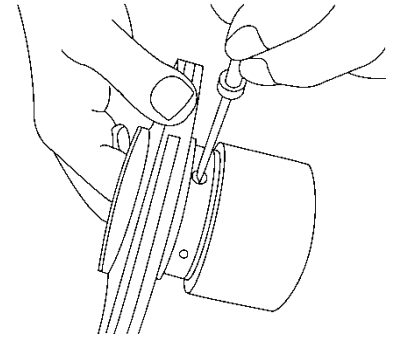
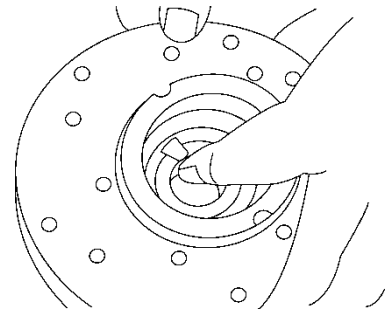

Figure 20

- Verify that there are no scratches or foreign material on the sealing surface of the front casing liner (1.3). Install the o-ring (73.1) into the recess in the front casing liner. Place front casing with liner (1.1 & 1.3) on rear casing (231). Make sure the spindle fits in front casing liner spindle support.
- Fasten the hex socket bolts (903.1 & 903.2 & 23) in a diagonal order applying equal torque to each. Required torque is 18.0 ft-lbs. Use a screwdriver to verify that the motor fan rotates smoothly.

## 14 Spare Parts

Appropriate spare parts are necessary to ensure continued pump operation. Expendable parts should always be kept on hand.

No.	Description	Material	Material Code	Pump Model					
				542/543	545	220	221	441	442
				Part#					
6	Spindle	High Purity Alumina Ceramic	CF/FF	MXM0151		MXM0174			
		SiC	KK	MXM0002		MXM0175			
72	Mouth Ring	PTFE with filler	CF/FF	MXM0063		MXM0204			
		SiC	KK	MXM0064		MXM0205			
314.1	Rear Thrust Collar	CFRPFA	CF/FF/KK	MXM0003		MXM0176			
230 + 237	Magnet Cap. Assy.	CFRETFE + HD Carbon	CF	MXM0004	MXM0012	MXM0177	MXM0178	MXM0267	
		CFRETFE + High purity AL. Cer.	FF	MXM0153	MXM0154	MXM0179	MXM0180	MXM0268	
		CFRETFE + SiC	KK	MXM0005	MXM0013	MXM0181	MXM0182	MXM0269	
73.1	O-ring	FKM	V	MXM0006		MXM0218		MXM0305	
		EPDM	E	MXM0007		MXM0220		MXM0306	
		Aflas®	A	MXM0008		MXM0221		MXM0307	
		Dai-El Perfluor®	P	MXM0014		MXM0217		MXM0308	
73.21	Gasket	FKM	V	MXM0009					
		EPDM	E	MXM0010					
		Aflas®	A	MXM0011					
		Dai-El Perfluor®	P	MXM0015					

1. Two gaskets are required per pump.



## 15 Dimensions and Weights

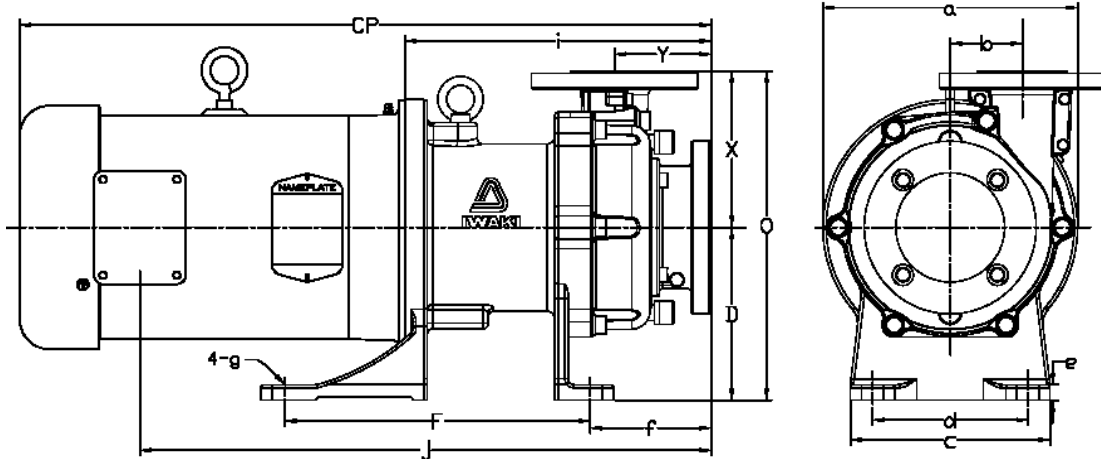

Dimensions in inches (mm)

Model	a	b	c	d	D	e	f	F	g	i	J	O	X	Y	CP*
MXM 22	7.87 (199.9)	2.01 (51.1)	5.91 (150.1)	4.33 (109.9)	4.53 (115.0)	0.39 (9.9)	3.74 (95.0)	6.50 (165.1)	0.47 (11.9)	9.98 (253.5)	15.80 (401.3)	9.33 (237.0)	4.80 (121.9)	3.46 (87.9)	19.27 (489.5)
MXM 441	8.54 (216.9)	2.26 (57.4)	6.69 (169.9)	5.12 (130.0)	5.31 (134.9)	0.55 (14.0)	4.43 (112.5)	9.84 (249.9)	0.55 (14.0)	10.55 (268.0)	17.0 (431.8)	10.83 (275.1)	5.51 (140.0)	4.17 (105.9)	19.84 (503.9)
MXM-442											18.0 (457.2)				21.73 (551.9)
MXM-542	9.04 (229.6)	2.56 (65.0)	7.09 (180.1)	5.51 (140.0)	6.10 (154.9)	0.55 (14.0)	4.29 (109.0)	10.83 (275.1)	0.55 (14.0)	11.46 (291.8)	17.92 (455.2)	11.61 (274.9)	5.51 (140.0)	3.43 (87.1)	21.90 (556.3)
MXM-543										10.87 (276.1)	20.27 (514.9)				24.70 (627.4)
MXM-545															

\* Varies according to motor manufacturer.

Iwaki America Corporation  
5 Boynton Road Hopping Brook Park Holliston MA 01746-1446 USA  
TEL: 508-429-1440 FAX: 508-429-1386 Website: [www.iwakamerica.com](http://www.iwakamerica.com)