



**HYPRO®**

## Series 9307 Hydraulically-Driven Centrifugal Pumps

Form L-1492  
Rev. B

---

### Original Instruction Manual

---



**SERIES 9307C**  
Hydraulically-Driven  
Centrifugal Pumps



**SERIES 9307CWS**  
Hydraulically-Driven  
Centrifugal Pumps with  
ForceField™ Technology

#### **Pentair**

375 5th Ave., New Brighton, MN 55112

Phone: (651) 766-6300 -OR- 800-424-9776 Fax: 800-323-6496

[www.hypropumps.com](http://www.hypropumps.com)

# Contents

Introduction .....	3
Description .....	3
Intended Use(s) .....	3
Misuses .....	3
Pump Technical Data .....	4-5
Fluid Pumping Applications .....	5
Tools .....	5
Lifting, Transport, and Intermediate Storage .....	6
Assembly and Installation .....	6
Assembly .....	6
Installation .....	6-8
Installation of Plumbing .....	8
Commissioning Start-Up, Operation, Shutdown .....	9
Information .....	9
Start-Up, Operation, Shutdown .....	9
Maintenance and Servicing .....	10
Information .....	10
Cleaning .....	10
Disposal .....	10
Parts Illustration .....	11-12
Troubleshooting .....	13
Repair Instructions .....	14-19
Limited Warranty on Hypro/SHURflo Agricultural Pumps and Accessories .....	back cover

# Introduction

## Description

Hypro centrifugal pumps are designed for agricultural and industrial spraying and transfer of a variety of fluids: water, insecticides, herbicides, wettable powders, emulsives, liquid fertilizers, etc. Hypro Series 9307 hydraulic motor-driven centrifugal pumps provide smooth performance. They can be conveniently mounted on the tractor or sprayer, becoming part of the vehicle's hydraulic system and freeing the PTO for other uses.

## Purpose of Manual

Hypro has provided this manual to provide instructions and requirements that must be met when installing, using and maintaining the product(s) identified on the cover.

If the product is sold, the seller must pass this manual on to the new owner.

The following special attention notices are used to notify and advise the user of this product of procedures that may be dangerous to the user or result in damage to the product.

### **ATTENTION**

Attention is used to notify of installation, operation, or maintenance information that is important but not safety related.



This symbol is used to denote the presence of an electrical hazard that will result in personal injury, death, or property damage.



This symbol is used to denote the presence of a hazard that will result in personal injury, death, or property damage.



**California Proposition 65 Warning** -- This product and related accessories contain chemicals known to the State of California to cause cancer, birth defects or other reproductive harm.

## Intended Use(s)

Hypro 9307 centrifugal pumps can be used in chemical spraying and transfer applications where high flow (370 GPM) and high pressure (135 PSI) capabilities are desired. They are designed to provide resistance to strong chemical attack. Stainless steel pumps are ideal for use with acid herbicide applications. Polypropylene pumps provide excellent resistance to corrosive chemicals. Pumps can operate in a variety of environments, but should never be used to pump fluids above 140°F (60°C) or below 32°F (0°C). Other common misuses are listed in the Misuses section of this manual. Contact Hypro technical services about any questions regarding specific uses.

## Misuses

Hypro centrifugal pumps are designed to operate effectively within the specified speed, pressure and environmental ranges specified in this manual. Operating a pump outside of these ranges will void the warranty and could cause damage to property, serious injury or death. Some common misuses of Hypro centrifugal pumps are:

- DO NOT run the pump faster than the maximum recommended speed.
- DO NOT run the pump higher than the maximum recommended pressure.
- DO NOT use pumps in explosive environments.
- DO NOT operate a pump with a gasoline engine in an enclosed area.
- DO NOT run pumps when the liquid has exceeded the maximum or minimum temperature limit (See Intended Uses).
- DO NOT pump non-approved liquids (See Fluid Pumping Applications).
- DO NOT pump water or other liquids for human consumption.
- DO NOT operate any Hypro pump under the influence of drugs or alcohol.
- DO NOT run pump in reverse of its intended rotation.
- DO NOT attach a pipe, hose or fittings to the pump that is not rated for the maximum pressure of the pump (outlet) or vacuum of the pump (inlet).
- DO NOT run the pump dry.

# Pump Technical Data

## Series 9307C/CWS Pump Specifications

Model No.	Max. Flow	Max. Pressure Rate (PSI)	Max. Hyd. (GPM)	Ports GPM	Hydraulic Ports	Max. Fluid Temp.	Max. Motor PSI	Dry Weight
9307C	370	135	23	3" NPT or 300 Universal Inlet 2" NPT or 220 Universal Outlet	7/8" SAE Inlet 1-1/16" SAE Outlet	140°F (60°C)	3000	86 lbs. (39 Kg)
9307CWS	370	135	23	300 Universal Inlet 220 Universal Outlet	7/8" SAE Inlet 1-1/16" SAE Outlet 7/16" SAE Case Drain	140°F (60°C)	3000	92 lbs. (42 Kg)

## Series 9307C/CWS Performance Data

### 9307C-GM10, 9307C-GM10-U: Performance in Water U.S. Units

Hyd. Flow GPM	GPM at 30 PSI	GPM at 40 PSI	GPM at 50 PSI	GPM at 60 PSI	GPM at 70 PSI	GPM at 80 PSI	GPM at 90 PSI	GPM at 100 PSI	GPM at 110 PSI
16	282	253	219	168	73				
17	318	288	258	222	174	95			
18	346	318	291	258	222	166	90		
19		361	338	311	281	250	201	137	
20		370	351	328	301	275	241	184	106

### 9307C-GM10, 9307C-GM10-U: Performance in Water Metric Units

Hyd. Flow LPM	LPM at 2.1 Bar	LPM at 2.8 Bar	LPM at 3.5 Bar	LPM at 4.1 Bar	LPM at 4.8 Bar	LPM at 5.5 Bar	LPM at 6.2 Bar	LPM at 6.9 Bar	LPM at 7.6 Bar
60.6	1067	958	829	636	276				
64.4	1204	1090	977	840	659	360			
68.1	1310	1204	1101	977	840	628	341		
71.9		1366	1279	1177	1064	946	761	519	
75.7		1400	1329	1241	1139	1041	912	696	401

### 9307C-GM10, 9307C-GM10-U: Performance in 28% Liquid Fertilizer U.S. Units

Hyd. Flow GPM	GPM at 50 PSI	GPM at 60 PSI	GPM at 70 PSI	GPM at 80 PSI	GPM at 90 PSI	GPM at 100 PSI	GPM at 110 PSI	GPM at 120 PSI	GPM at 130 PSI
16	254	227	189	133					
17	261	256	243	213	172				
18	262	256	252	250	242	209	163	70	
19		262	257	250	249	239	217	191	
20		262	257	252	249	249	245	227	195

### 9307C-GM10, 9307C-GM10-U: Performance in 28% Liquid Fertilizer Metric Units

Hyd. Flow LPM	LPM at 3.5 Bar	LPM at 4.1 Bar	LPM at 4.8 Bar	LPM at 5.5 Bar	LPM at 6.2 Bar	LPM at 6.9 Bar	LPM at 7.6 Bar	LPM at 8.3 Bar	LPM at 9.0 Bar
60.6	961	859	715	503					
64.4	988	969	920	806	651				
68.1	992	969	954	946	916	791	617	265	
71.9		992	973	946	942	905	821	723	
75.7		992	973	954	942	942	927	859	738

### 9307C-GM12, 9307C-GM12-U, 9307CWS-GM12: Performance in Water U.S. Units

Hyd. Flow GPM	GPM at 30 PSI	GPM at 40 PSI	GPM at 50 PSI	GPM at 60 PSI	GPM at 70 PSI	GPM at 80 PSI	GPM at 90 PSI	GPM at 100 PSI	GPM at 110 PSI
16	222	180	115						
17	246	212	166	92					
18	274	245	209	157	58				
19	302	272	242	203	150				
20	326	298	271	240	196	142			
21	345	324	297	269	238	194	140		
22		345	322	297	270	236	193	138	
23		370	344	323	299	273	235	194	137

### 9307C-GM12, 9307C-GM12-U, 9307CWS-GM12: Performance in Water Metric Units

Hyd. Flow LPM	LPM at 2.1 Bar	LPM at 2.8 Bar	LPM at 3.5 Bar	LPM at 4.1 Bar	LPM at 4.8 Bar	LPM at 5.5 Bar	LPM at 6.2 Bar	LPM at 6.9 Bar	LPM at 7.6 Bar
60.6	840	681	435						
64.4	931	802	628	348					
68.1	1037	927	791	594	220				
71.9	1143	1030	916	768	568				
75.7	1234	1128	1026	908	742	537			
79.5	1306	1226	1124	1018	901	734	530		
83.3		1306	1219	1124	1022	893	731	522	
87.1		1400	1302	1223	1132	1033	889	734	519

## Series 9307C/CWS Performance Data - cont'd.

**9307C-GM12, 9307C-GM12-U, 9307CWS-GM12: Performance in 28% Liquid Fertilizer U.S. Units**

Hyd. Flow GPM	GPM at 40 PSI	GPM at 50 PSI	GPM at 60 PSI	GPM at 70 PSI	GPM at 80 PSI	GPM at 90 PSI	GPM at 100 PSI	GPM at 110 PSI	GPM at 120 PSI	GPM at 130 PSI	GPM at 140 PSI
16	228	204	159	100							
17	234	219	190	147	49						
18		247	223	194	146	49					
19		255	239	221	191	151	55				
20		260	252	240	220	191	150	63			
21		260	254	248	237	224	196	159	87		
22		260	254	248	240	230	214	194	159	101	
23		260	254	249	249	242	237	227	211	174	133

**9307C-GM12, 9307C-GM12-U, 9307CWS-GM12: Performance in 28% Liquid Fertilizer Metric Units**

Hyd. Flow LPM	LPM at 2.8 Bar	LPM at 3.5 Bar	LPM at 4.1 Bar	LPM at 4.8 Bar	LPM at 5.5 Bar	LPM at 6.2 Bar	LPM at 6.9 Bar	LPM at 7.6 Bar	LPM at 8.3 Bar	LPM at 9.0 Bar	LPM at 9.7 Bar
60.6	863	772	602	379							
64.4	886	829	719	556	185						
68.1		935	844	734	553	185					
71.9		965	905	836	723	572	208				
75.7		984	954	908	833	723	568	238			
79.5		984	961	939	897	848	742	602	329		
83.3		984	961	939	908	871	810	734	602	382	
87.1		984	961	942	942	916	897	859	799	659	503

## Fluid Pumping Applications

Application	Pump Materials Compatibility		Comments
	YES	NO	
WEED CONTROL CHEMICALS	X		
INSECT CONTROL	X		
BRUSH CONTROL	X		
PEST CONTROL CHEMICALS AND FUMIGANTS	X		
LIQUID FERTILIZERS	X		
POWDERED FERTILIZERS	X		
FLUID TRANSFER	X		
BLEACH	X		
MILD ACIDS	X		
STRONG ACIDS		X	NOT FOR ACIDS WITH pH < 3

The following chemicals should never be put through any Hypro pump:

- Gasoline (petrol)
- Kerosene/Kerosine (paraffin)
- Diesel fuel
- Ceramic slurries
- Sewage
- Potable water
- Abrasive fluids
- Anhydrous ammonia
- Any other chemicals not compatible with the pump materials

## Tools

Hypro centrifugal pumps and mounting assemblies are designed with Imperial (inch) bolts. However, there are many metric (mm) sizes which will also work with these bolts. In most cases, an adjustable spanner (crescent) wrench can be used. For other cases, refer to an Imperial-to-metric conversion chart.

## Lifting, Transport and Intermediate Storage

### Lifting Instructions

- Before attempting to lift a Hypro pump, ensure that the surrounding working area is free of hazards which could cause injury or damage to property.
- During lifting operations, any personnel not involved in the lift should not enter the working area.
- If lifting hooks, rope or chains are being used for a lift, they must be free of damage and be rated to carry 150% of the weight of the load to be lifted.
- Always wear steel-toed shoes and cut-resistant gloves when attempting to lift.
- When lifting and carrying, always keep the pump close to your body. (See Figure 1.)
- When starting the lift, bend your knees and keep your back straight. (See Figure 1.) Tightening the stomach muscles will help hold one's back straight.
- During the lift, use one's legs to do the work. Never use your back and make sure your legs are at least shoulder-width apart. (See Figure 1.)



Figure 1

### Packaging Descriptions and Unpacking Instructions

- Hypro plunger pumps are shipped in cardboard boxes for safe transporting.
- When pumps are shipped in large quantities, they may be put on a pallet to allow for easy storage, lifting and handling.
- Before lifting any pump or pallet, determine the weight via the attached packing slips to establish what lifting equipment or method should be used.
- Once the pump is unpacked, dispose of all the packaging in a manner which follows local and national regulations.

### Transport

- All Hypro pumps are capable of being transported by air, sea, rail or motor vehicle. When the pump is shipped, ensure that the pump is moved in accordance with local and national laws, and ensure the pump is secured to the vehicle to prevent unwanted movement which could cause damage to person or property. Prior to shipping, all fluids should be removed from the pump.

### Storage

- New pumps in their boxes can be stored years as long as the port plugs are not removed. Once the plugs have been removed, if the pump is not to be used for an extended period of time (i.e. more than 30 days), the pump must be winterized as described in the Cleaning section of this manual.

## Assembly and Installation

### Assembly

This pump comes completely assembled.

### Installation

**⚠ ATTENTION** Pumps must be installed in accordance with Hypro's installation instructions. Failure to follow instructions will automatically void the Limited Warranty.

#### Preliminary to Mounting

Consult the owners manual to determine the type and capacity of the hydraulic system. Make sure the hydraulic system is recommended to operate with a continuous load. Refer to the Pump Selection Guide to confirm you have the proper pump for your hydraulic system.

## Installation Instructions - cont'd.

Check to see that the pump impeller can be turned by hand. (Turn the shaft clockwise using a deep socket wrench on the impeller nut.) If it cannot be turned, open the pump casing to look for obstructions. Clean out any corrosion build up where the casing fits over the eye of the impeller.

### Pump Inlet Line

To achieve full capacity from the pump, the inlet line should be at least the same size as the inlet port on the pump. Reducing this line size will restrict the capabilities of the pump. The line must also be free of air leaks. Check all fittings and connections in the suction line for tightness. The introduction of air may affect the priming and pumping capabilities of the pump. Use good quality suction hose that will not be collapsed by suction.

For non self-priming models, the centrifugal pump should be mounted below the liquid level and as near to the liquid source as possible to allow for the shortest suction line practical. To achieve optimal performance, the suction line should slope down into the pump. Avoid rises and humps that could trap air in the line to the pump. The suction line and pump should be filled with liquid prior to starting the pump, and all discharge lines should be open.

### Pump Outlet Line

The recommended orientation for the outlet port is pointing straight up. This allows liquid to stay in the pump while it is priming. The outlet line should be the same size as the pressure port on the pump to give the optimal flow. The line should have as few restrictions and elbows as possible to optimize the pump performance and reduce pressure drop from the pump to the spray tips.

### Priming the Pump

**▲ ATTENTION** The 9307C Series pump must not be run dry.

Before starting the pump, the inlet line and pump must be filled with liquid and all discharge lines must be open. Standard, non-wet seal pumps must not be run unless they are completely filled with liquid because there is a danger of damaging the mechanical seal, which depends on the liquid for its lubrication. On pumps with ForceField™ Technology (wet seal), dry run cannot exceed 15 minutes in one single event, or there is a risk of damage to the seal.

Non-self-priming models should be mounted below the level of the liquid. The suction line should slope down to the pump and be free of dips and bends. If this cannot be done, a foot valve should be installed in the end of the inlet line so that the line can be completely filled with liquid before starting the pump.

For best priming results, the top vent plug should be removed from the pump casing, and a vent line (1/4" [6.35 mm] tubing is sufficient) should be installed running back to the top of the tank. This line prevents air lock and allows the pump to prime itself by bleeding off trapped air. The small stream of liquid that returns to the tank during operation is negligible. The discharge from this line should be positioned in the tank above the high liquid level. Self-priming models can be primed by removing the top vent plug and filling the priming chamber. The priming chamber will fill to the level of the inlet port. After use, the priming chamber should be flushed and drained to avoid chemical corrosion and damage from freezing. Drain by removing the lower drain plug.

### Controlling the Pump Flow

The best way to control the flow is by incorporating two control valves in a pipe tee immediately after the strainer in the discharge line. This permits controlling agitation flow independently of nozzle flow.

In any centrifugal pump, it is the large volume of liquid which puts load on the drive. Use only the flow needed to develop the pressure required at the boom and to maintain adequate agitation. Hydraulic motor-driven centrifugal pumps are easily adjusted to the exact flow required, as explained in the Operating Instructions of this manual.

### Centrifugal Pump Control

Hypro now offers many different components for spraying systems. The Hypro centrifugal pump control incorporates the electric flow control valve, a self-cleaning line strainer, a visual pressure gauge and a manual agitation control valve.

### Flow Control Valve

A high-flow electric proportional valve allows for maximum flow control to the boom valves. It provides smooth, rapid control that can be controlled from either an electronic rate controller or switch box.

### Strainers

The recommended placement of the strainer for a centrifugal pump is in the pump outlet line. This will eliminate any possible restriction that the strainer could create if it were installed in the inlet line. Ensure that the proper strainer size and screen mesh are used to limit the pressure drop and achieve the best filtration. Line strainers can also be installed in the tank fill line to filter liquid as it is loaded into the tank as well as in the boom lines to further filter the solution prior to the spray tips. Tank baskets can also be used to filter material added through the tank lid.

## Installation Instructions - cont'd.

### Agitation

The centrifugal pump control contains a manual agitation control valve that can be adjusted to provide the right amount of flow to the jet agitators in the tank to ensure proper mixing within the tank.

### Flowmeter

To eliminate the mechanical problems of a turbine flowmeter, we recommend that an electromagnetic flowmeter be used. These flowmeters have no moving parts to wear out and will provide a more consistent and accurate flow reading. They can be input into just about any electronic rate controller or switch box.

## Installation of Plumbing

### Boom Section Valves

For rapid response and reliability, we recommend electric plunger valves be used for boom control. The valves should be sized accordingly to minimize the pressure drop and maximize the flow rate. The boom tubing or hose should be sized accordingly to ensure that a pressure drop in the lines does not occur, causing inconsistent pressures at the nozzles.

### Nozzle Bodies

Nozzle bodies with shut-off check valves are recommended to eliminate dripping from the spray tips when the boom valves are shut down.

### Hooking Up the Hydraulic Motor to the Tractor Hydraulic System

Hypro Series 9307 hydraulic motor-driven pumps can be mounted on either the tractor or sprayer. When hooking up, make sure that no dirt or liquid gets into the hydraulic motor. **Keep all hydraulic connections clean.** Be sure to connect the hydraulic motor into the system correctly by putting the pressure line to the (IN) Port and return line to the (OUT) Port. For maximum performance, the hydraulic lines should also be at least 3/4" [19 mm] in size.

Standard spool valves, which are found on all tractor hydraulic systems, may cause potentially damaging high peak pressures in the hydraulic system when closed because of abrupt shut-off of oil flow in both the supply and return lines. When shutting off the pump, move the selector to the **FLOAT** position to allow the centrifugal pump to come to a stop gradually.

**⚠ ATTENTION** The 9307CWS Series case drain line should be used from hydraulic motor to tank.

**For further information regarding Hypro products, contact your local dealer or Hypro directly at [www.hypropumps.com](http://www.hypropumps.com) or by calling 1-800-424-9776.**

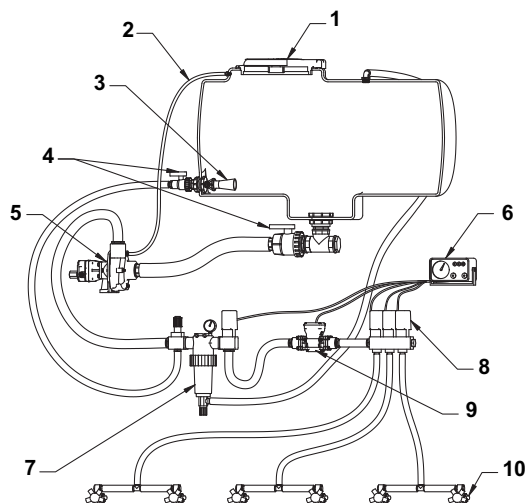

**Centrifugal Plumbing Hook-up**

REF. NO.	DESCRIPTION
1	Tank Lid
2	Vent Line #3430-0456
3	Jet Agitator
4	Shut-off Ball Valves
5	Centrifugal Pump
6	Spray Control Console
7	Centrifugal Pump Control
8	Manifold Boom Valve
9	Electromagnetic Flowmeter
10	Compact Jet Turret Nozzle Body



# Commissioning Start-Up, Operation, Shutdown

## Start-Up, Operation, and Shutdown

### Before Starting the Pump:

 Secure the outlet lines before starting the pump. An unsecured line may whip, causing personal injury and/or property damage.

 Check hose for weak or worn condition before each use. Make certain that all connections are tightly secured.

The sound pressure level of the pump is 80 dBA. Observe all safety precautions when operating the pump within close proximity for extended periods of time by wearing hearing protectors. Extended exposure to elevated sound levels will result in permanent loss of hearing acuteness, tinnitus, tiredness, stress, and other effects such as loss of balance and awareness.

### Start-Up and Operation:

#### Open Center Systems - All Models Adjusting Centrifugal Pump Output

#### ATTENTION

1. Start the tractor. Leave the directional valve in the neutral position and allow hydraulic oil to circulate for approximately 10 to 15 minutes or until adequately warmed.
2. Prime the centrifugal pump with all valves open (See the Installation Instructions and System Configuration Diagram).
3. Close the agitation line valve and keep the control valve and the boom shut-off valve open. Note the spray pressure.
4. Open the agitation line valve until you have desired circulation in the tank. Recheck the spray pressure. If it is too low, close down the agitation line valve until the desired spray pressure is reached. If the spray pressure is too high, throttle the centrifugal pump by closing down the control valve.

#### Closed Center (Load Sensing) - All Models

Many tractors are being introduced with load sensing systems (also referred to as flow and pressure- compensated systems) which simplify system setup and eliminate many of the problems associated with using the wrong size pump motors on a given hydraulic system. Usually, any of Hypro's 9300HMC models may be used on this type of system, provided the hydraulic system produces sufficient oil flow for the hydraulic motor being used (Refer to the Pump Selection Guide).

This system maintains a constant flow of hydraulic oil for a given pressure drop. The flow is adjustable with a flow control valve installed in the hydraulic system (such as the Tortoise/Hare control on John Deere tractors). Because this system has adjustable flow, there is no need to bypass hydraulic oil as in an open center system, or to restrict the flow with orifices as in a closed center pressure- compensated system.

#### Adjusting Centrifugal Pump Output

1. Set the tractor hydraulic flow control valve for minimum hydraulic oil flow to the remote outlet (Tortoise position).
2. Start the tractor and allow the hydraulic oil to circulate for approximately 10 to 15 minutes or until adequately warmed.
3. Prime the centrifugal pump with all valves open (See the Installation Instructions and System Configuration Diagram).
4. Close the agitation line valve and open the control valve and the boom shut-off valve.
5. Slowly adjust the tractor hydraulic flow control valve until the desired boom pressure is attained.
6. Open the agitation line valve until sufficient agitation is observed. If spray pressure drops, readjust the tractor hydraulic flow control valve to restore it to the desired pressure.

### Cleaning and Shutdown:

#### Flush Pump After Use

One of the most common causes for faulty pump performance is gumming or corrosion inside the pump. Flush the pump and entire system with a solution that will chemically neutralize the liquid pumped. Mix this solution according to the manufacturer's directions. This will dissolve most residue remaining in the pump, leaving the inside of the pump clean for the next use.

#### To Prevent Corrosion

After cleaning the pump as directed above, flush it with a permanent-type automobile antifreeze (Prestone<sup>®</sup>, Zerex<sup>®</sup>, etc.) containing a rust inhibitor. Use a 50% solution, half antifreeze and half water, or fill the pump with FLUID FILM<sup>®</sup> and then drain it. A protective coating of FLUID FILM<sup>®</sup> will remain on the inner pump surfaces. Save the excess FLUID FILM<sup>®</sup> for the next application. Plug the ports to keep out air during storage. For short periods of idleness, noncorrosive liquids may be left in the pump, but air must be kept out. Plug the ports or the seal port connections.

# Maintenance and Servicing

## Information

When servicing your pump, you should adhere to the following safety guidelines:



1. Disconnect power supply before servicing.
2. Release all pressure within the system before servicing any component. Flush with water.
3. Always drain and flush pump before servicing or disassembling for any reason.
4. Always drain and flush pumps prior to returning unit to Hypro for repair.
5. Before returning pump for service/repair, drain out all liquids and flush unit with neutralizing liquid. Then drain the pump. Attach tag or include written notice certifying that this has been done. It is illegal to ship or transport any hazardous chemicals without United States Environmental Protection Agency Licensing.



6. Never use your hand to check the condition of hydraulic lines or hoses. If hydraulic fluid penetrates the skin, get medical help immediately. Failure to get proper medical help may result in loss of limb or life. The safest way to check hydraulic lines or hoses is by holding a piece of cardboard next to the hydraulic line or hose.

## Cleaning

### Care of Pump

Your pump will last longer and give best performance when properly taken care of. Proper pump care depends on the liquid being pumped and when the pump will be used again. After each use, flush pump with a neutralizing solution for the liquid just pumped. Follow with a clean water rinse. This is especially important for corrosive chemicals. It is good practice to clean the pump after each use to prevent deposits from forming and damaging the pump. Using an antifreeze/rust inhibitor not only coats the interior of the pump, but acts as a lubricant as well, keeping valves from sticking and protecting against any remaining moisture freezing in cold weather. For infrequent use and before long periods of storage, drain pump thoroughly. Open any drain plugs, remove suction hose from liquid, and blow out pump with air. An antifreeze/rust inhibitor should be injected into the pump before both ports are plugged and the pump is stored. Plug all ports to keep out air until pump is used again.

## Disposal

When disposing of a Hypro pump, be sure to remove all fluids from the pump before scrapping. These fluids should be disposed of in a manner which complies with local and national regulations. Never dump fluids onto the ground. Once the pump is free of all fluids, it must be scrapped in accordance with local and national laws.

## Replacement Parts

The parts illustrations on the following pages show the pumps and their replacement parts. Only genuine Hypro replacement parts should be used. Failure to follow this warning can result in damage to property, serious injury or death, and will void your warranty. If the pump malfunctions or is defective, it should be sent back to Hypro for service.

# Models 9307C Parts Illustration and Repair Kits

(Includes Models 9307C-GM10, 9307C-GM12, 9307C-GM10-U, & 9307C-GM12-U)

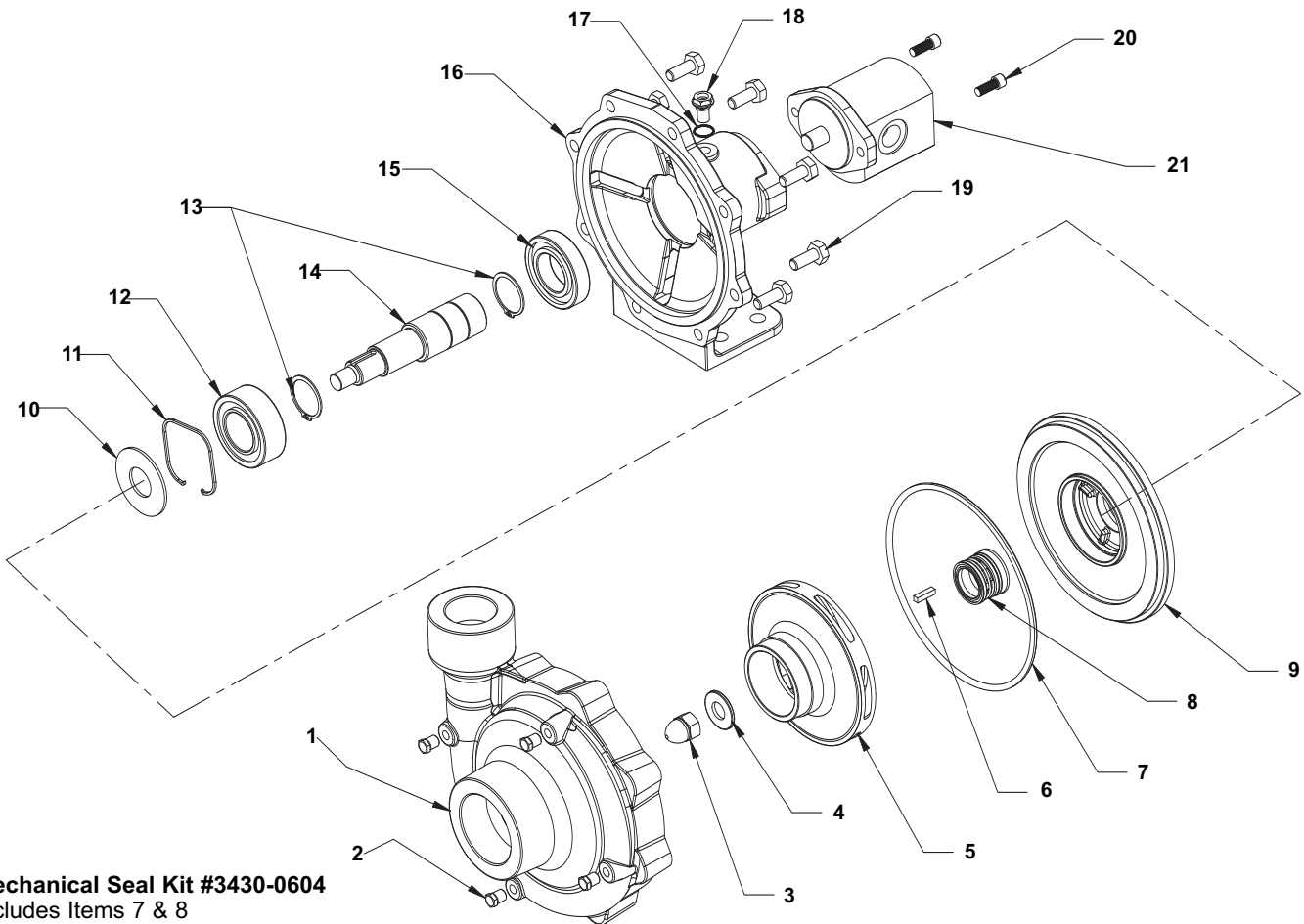

**Mechanical Seal Kit #3430-0604**  
Includes Items 7 & 8

**Bearing Kit #3430-0671**  
Includes Items 10, 11, 12, 13 & 15

**Impeller Hardware Kit #3430-0612**  
Includes Items 3, 4 & 6

**Hydraulic Motor Seal Replacement #3430-0611**  
For seal replacement in Motor #2500-0036 (GM10)

**Hydraulic Motor Seal Replacement #3430-0616**  
For seal replacement in Motor #2500-0046 (GM12)

**NOTE:** When ordering parts, give quantity, part number, description and complete model number. Reference numbers are used ONLY to identify parts in the drawing and are NOT to be used as order numbers.

Ref. No.	Qty. Req'd	Part No.	Description
1*	1	0150-9300C	Pump Casing
1**	1	0151-9300C	Pump Casing (Universal Flange)
2	4	2406-0039	Pipe Plug
3	1	2253-0010	Acorn Nut
4	1	2270-0094	Washer
5	1	0400-9300S	Impeller
6	1	1610-0058	Key
7	1	1721-0208	O-Ring
8	1	2120-0043	Mechanical Seal
9	1	0755-9300C	Seal Flange
10	1	2270-0093	Slinger
11	1	1820-0040	Retaining Ring

Ref. No.	Qty. Req'd	Part No.	Description
12	1	2005-0006	Double Row Ball Bearing
13	2	1810-0001	Retaining Ring
14	1	0500-9305	Shaft Assembly
15	1	2007-0063	Ball Bearing
16	1	0757-9300C	Mounting Flange
17	1	1720-0209	O-Ring
18	1	2300-0040	Plug
19	8	2210-0131	Bolt
20	2	2210-0026	Bolt
21	1	2500-0036	Hydraulic Motor (GM10)
21	1	2500-0046	Hydraulic Motor (GM12)

\*Includes a Stainless Steel Wear Ring and 4 Pipe Plugs (Ref. No. 2)

\*\*Used in -U "Universal Flange" models, includes Stainless Steel Wear Ring and 4 Pipe Plugs (Ref. No. 2)

# Model 9307CWS-GM12 Parts Illustration

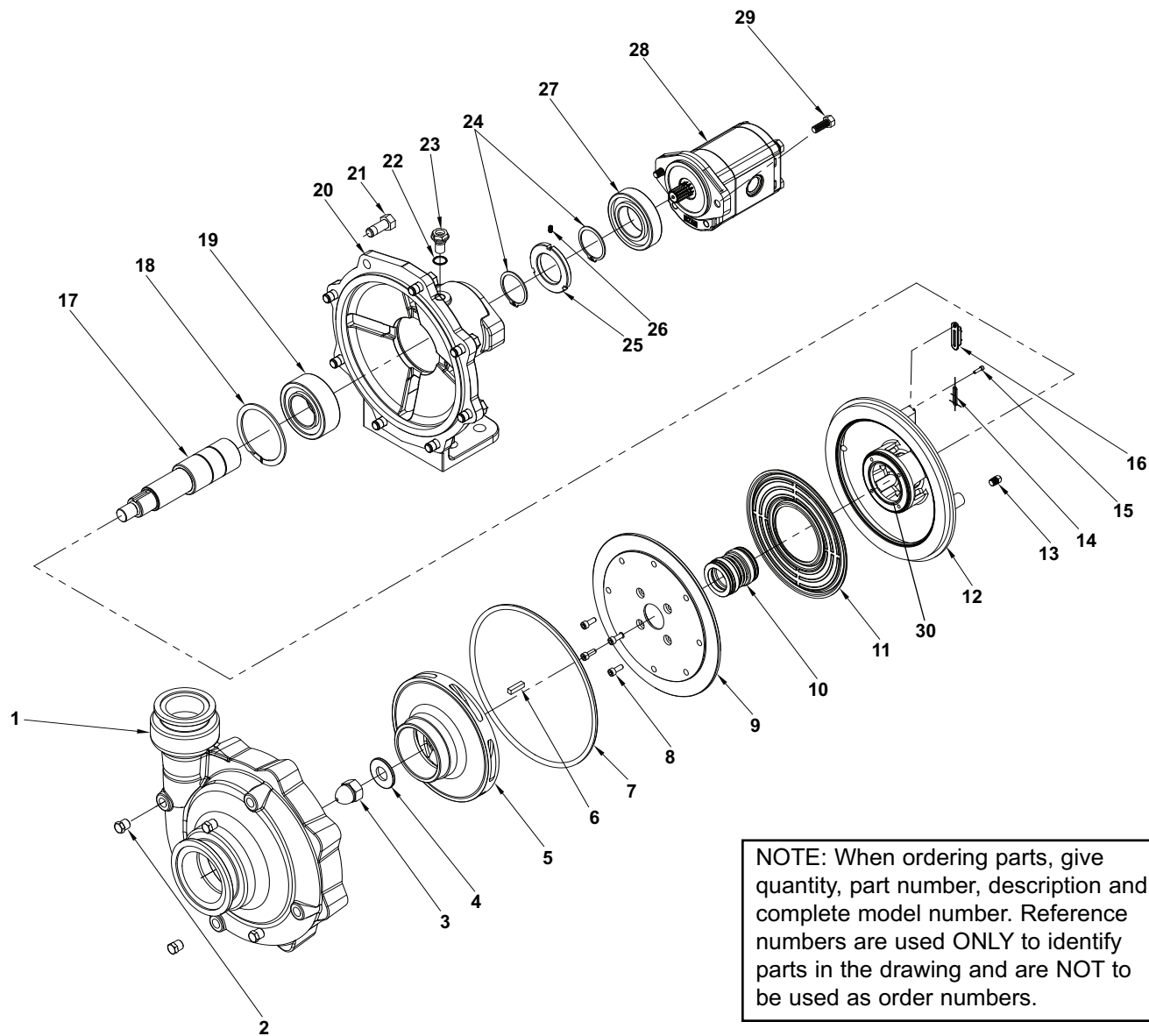

**Impeller Hardware Kit #3430-0612:** Includes Items 3, 4 & 6

**Hydraulic Motor Seal Replacement #3430-0616:** For seal replacement in Motor #2500-0123 (GM12)

**Repair Kit #3430-0813:** Includes Items 7, 10, 11, 14, 16, 19, 27, 30 and (parts not shown) #1410-0134 Wear ring, #2160-0096 Wet seal fluid, #3010-0252 Tool-mech. seal, and #3010-0253 Tool-front plate.

Ref. No.	Qty. Req'd.	Part Number	Description
1	1	0151-9300C	Pump Casing (Universal Flange)
2	4	2406-0039	Pipe Plug
3	1	2253-0010	Acorn Nut
4	1	2270-0094	Washer
5	1	0401-9307S	Impeller
6	1	1610-0058	Key
7	1	1721-0208	O-ring
8	4	2220-0124	Screw
9	1	0751-9307	Front Chamber Plate
10	1	2120-0061	Mechanical Seal
11	1	2535-0012	Membrane
12	1	0752-9307A	Back Chamber Plate
13	2	2406-0016	Pipe Plug
14	1	23358	O-ring
15	1	2220-0128	Socket Head Screw

Ref. No.	Qty. Req'd.	Part Number	Description
16	1	2630-0022	Sight Glass
17	1	0502-9307	Shaft Assembly
18	1	1820-0040	Retaining Ring
19	1	2005-0006	Bearing (dual-layer)
20	1	0757-9300C	Mounting Flange
21	8	2210-0131	Bolt
22	1	1720-0209	O-ring
23	1	2300-0040	Plug
24	2	1810-0001	Retaining Ring
25	1	1420-0031	Tone Wheel
26	1	2230-0047	Set Screw
27	1	2007-0063	Bearing
28	1	2500-0123	Hydraulic Motor
29	2	2210-0026	Bolt
30	1	1721-0228	O-ring

## Troubleshooting

If the proper Hydraulic Pump Unit has been selected according to Hypro recommendations, and the unit has been correctly plumbed into the hydraulic system, operation should be quite satisfactory. If spraying performance is unsatisfactory or hydraulic system heat is excessive etc., check the following troubleshooting guide for possible problems and solutions.

### Troubleshooting Guide

Symptom	Probable Cause(s)	Corrective Action(s)
Low discharge	Pump not primed	Remove topmost vent plug from face of pump and run pump to expel trapped air (See Installation Instructions).
	Air leak in inlet line	Check and reseal inlet fittings.
	Blocked or clogged line strainer	Inspect strainer and clear any debris from screen.
	Impeller plugged	Inspect and clear obstruction.
	Undersize inlet line or collapsed hose	Suction line should be the same diameter as inlet port of pump or larger.
	Improperly sized hydraulic motor	Refer to Pump Selection Guide to determine proper size hydraulic motor for your hydraulic system.
	Eye of impeller rubbing on volute	Remove volute (front cover) and inspect the impeller. If wear detected, sand the impeller eye O.D. with emery cloth.
Hydraulic system overheating	Improper hydraulic motor size	Refer to Pump Selection Guide to determine proper size for your hydraulic system.
	Insufficient hydraulic hose size	Check hydraulic hose size. Hose should be at least 1/2" [12.7 mm]. For large open-center systems, 3/4" [19.05 mm].

## Repair Instructions (9307C Series Only)

### Pump Housing Disassembly

1. Using a 3/4" wrench, remove the eight Hex Head Bolts holding the Pump Casing to the Mounting Flange.

#### **[NOTE]**

Once removed, turn the cover until mounting holes are exposed. Place a screwdriver on each side of the cover and pry away the mounting flange (See Figure 1).

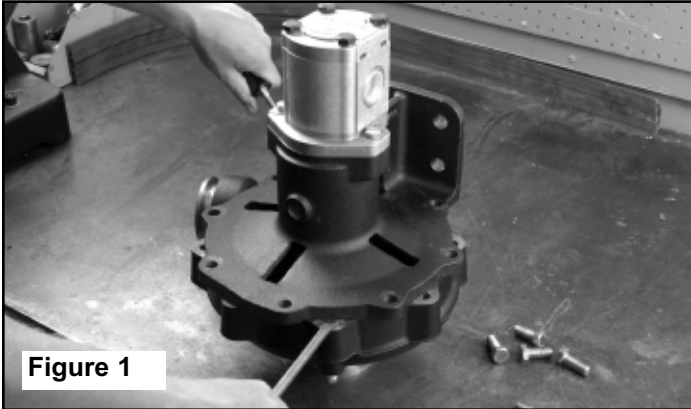

Figure 1

2. To remove the Impeller Nut, insert a large screwdriver or file (at least 10" [254 mm] long) into Impeller Vanes to prevent Impeller from turning when loosening nut. Use a 1-1/16" socket wrench to remove the Impeller Nut by turning it counterclockwise (See Figure 2).



Figure 2

3. Once nut [and washer] is removed, place a screwdriver on each side behind the Impeller and pry away from the Mounting Flange (See Figure 3). Remove Key from the Shaft. Remove O-ring from the Mounting Flange.



Figure 3

### Pump Seal Removal

1. Lightly lubricate the shaft for easier removal of the seal. Using two screwdrivers positioned opposite each other, pry the rotary portion of the seal from the shaft (See Figure 4).

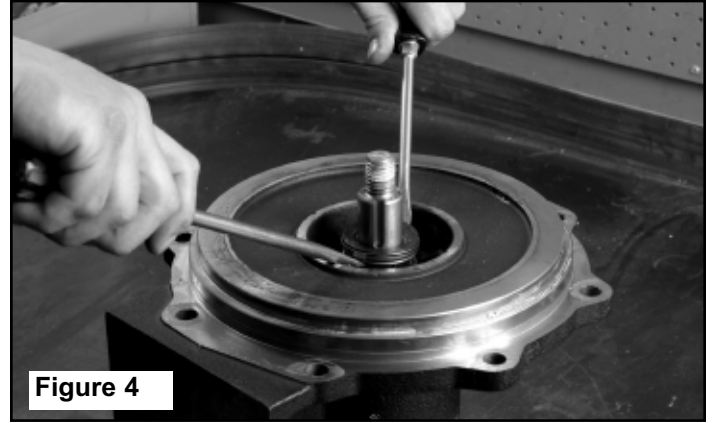

Figure 4

2. Lift the seal flange off of the mounting flange. Use screwdrivers to pry loose, if necessary.
3. Using a screwdriver and hammer, tap out the stationary portion of the mechanical seal from the motor side of the seal flange.

#### **[NOTE]**

The seal will be damaged by removal in this manner. A new seal must be used when pump is reassembled.

In the case of a severe pump seal leak, inspect the shaft/bearing assembly for possible contamination.

### Clean-Up Of Pump Housing

1. Using a circular bottle-type wire brush with air or hand drill, clean the outlet port, inlet port and the sealing areas of the o-ring on the pump casing and seal flange. Using the port brush, clean the seal cavity in the mounting flange.
2. After wire brush cleaning, it is recommended that the pump casing and seal flange be further cleaned in a solvent tank to remove rust and corrosion particles.

### Bearing Removal

1. Using a 9/16" wrench, remove the two motor mounting bolts. Lift the hydraulic motor from the mounting flange.
2. Remove slinger from shaft. Use a screwdriver to pry and guide the snap ring out of the mounting flange (See Figure 5).

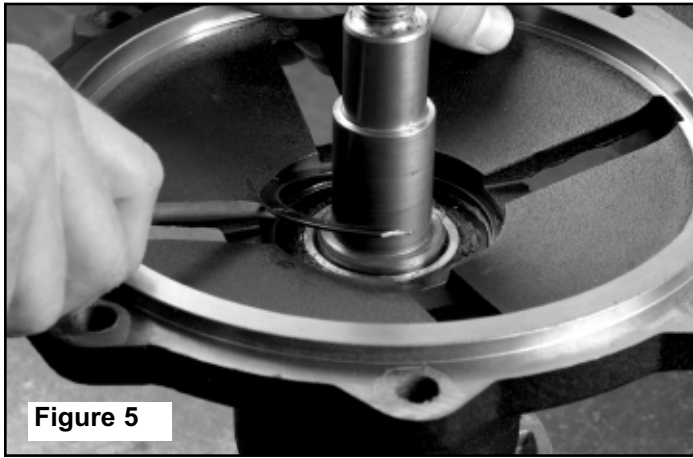

**Figure 5**

3. Set the mounting flange shaft side down in a press to remove the bearing and shaft assembly (See Figure 6).

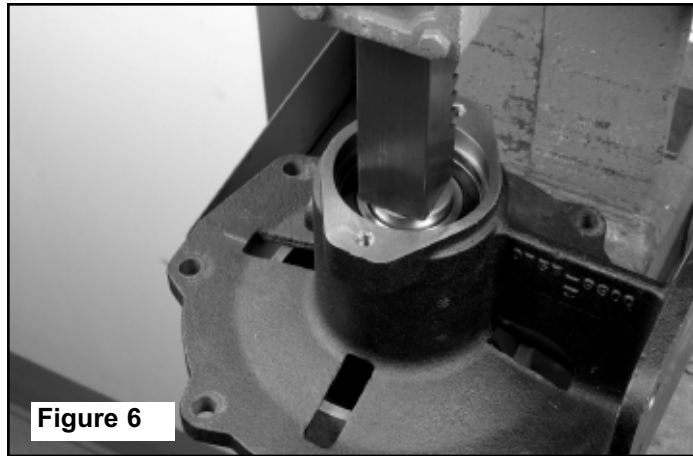

**Figure 6**

4. Support the bearings only in a press to remove from the shaft. Use a snap ring pliers to remove retaining rings, if necessary (See Figure 7).

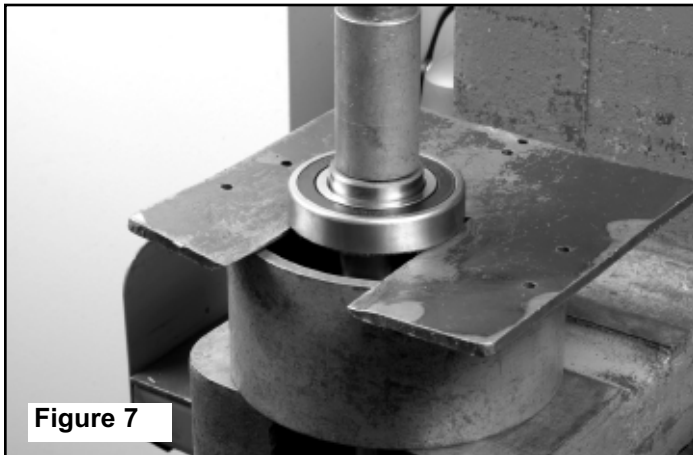

**Figure 7**

### Pump Assembly

1. Assemble the retaining rings to the pump shaft, using a snap ring pliers.
2. Press the bearings onto the pump shaft using a press.
3. Using a press, install the pump shaft and bearing assembly into the mounting flange.

4. Spread the snap ring by grabbing the open ends and pulling them apart, like extending a spring. Guide the retaining ring into the mounting flange using a screwdriver for assistance (See Figure 8).



**Figure 8**

5. Install the slinger onto the pump shaft.
6. Using soap and water as a lubricant, install the stationary half of the mechanical seal into the seal flange. Press it into place using a rag over the seal face and a 1-3/8" plastic guide (See Figure 9). Assemble the seal flange and mechanical seal. Assemble onto the mounting flange, taking care to avoid hitting the mechanical seal on the pump shaft.



**Figure 9**

7. Install the rotary portion of the mechanical seal onto the pump shaft, using soap and water as a lubricant.
8. Place the impeller, washer and a cover nut onto the pump shaft. Use medium strength thread locker on the acorn nut. Torque to 80 ft.-lbs. using a 1-1/16" socket.
9. Install the o-ring in the pump casing, lubricate the o-ring with soap and water. Place the pump casing on the mounting flange. Flip the assembly over onto the inlet part of the pump casing. Install the casing bolts with medium strength thread locker and torque to 75 ft.-lbs. using a 3/4" wrench.
10. Apply anti-seize to the hydraulic motor shaft. Place the hydraulic motor onto the pump assembly. Apply medium strength thread locker to the motor mounting bolts, torque to 25 ft.-lbs. using a 9/16" wrench.

## Hydraulic Motor Seal

### Disassembly Instructions

1. Clamp the motor in a vise with the bolts facing up. Take caution to avoid damaging the machined surfaces of the motor. Remove the bolts using a 17 mm wrench. See Figure 10.
2. Remove the rear cover of the motor. Mark the balancing plate and body to ensure proper reassembly. See Figure 11. Remove the balancing plate for seal replacement. Place the rear cover back on the motor.
3. Remove the motor from the vise and set it on the rear cover. Remove the front cover. Mark the balancing plate and body to ensure proper reassembly. See Figure 11. Remove the balancing plate for seal replacement. Remove the drive and driven gear. Inspect all components for worn parts. If non-seal components are worn, replace motor assembly.
4. Remove snap ring and support ring. Punch shaft seal out using a screwdriver and soft mallet.

### Assembly Instructions

5. Place shaft seal in front cover, spring side down, followed by the support ring and snap ring.
6. Place rear balancing plate in the body, making sure there is proper alignment. Place drive gear and driven gear in the body and rear balancing plate. Set the front balancing plate over the shafts and into the body. Thoroughly grease the splines of the drive shaft before placing the front cover on the body, pressing onto the guide pins.
7. Rotate the pump and reclamp in a vise. Set the rear cover over the guide pins. Install bolts and torque to 44 in.-lbs.



Figure 10

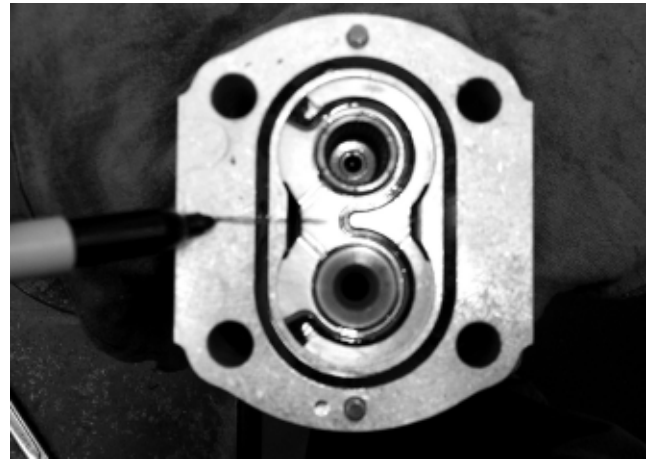
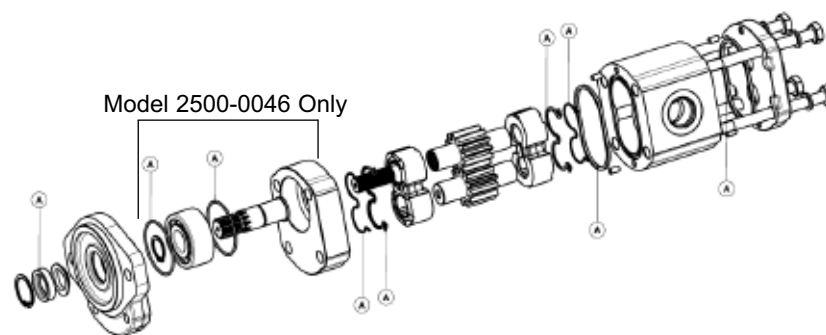

Figure 11





## Repair Instructions (9307CWS Series Only)

### Pump Housing Disassembly

1. Pump housing disassembly is the same as the standard 9307. See the housing disassembly section for the standard pump to see how the pump housing is removed.

### Pump Seal Removal

1. To remove the seal, first unscrew the four Allen bolts holding the front chamber plate in place, then lift the front chamber plate off of the rear chamber plate.
2. After removing the diaphragm, lightly lubricate the shaft for easier removal of the seal. Using two screwdrivers positioned opposite each other, pry the front rotary portion of the seal from the shaft. If the seal can come off of the rubber boot, the boot can be removed by grabbing it with a small nose pliers.
3. Lift the rear chamber plate off of the mounting flange. Use screwdrivers to pry loose, if necessary. The rear portion of the mechanical seal will come off when the rear chamber plate is removed.

#### **NOTE**

When prying off the rear chamber plate with screwdrivers, be sure to pry evenly or the shaft may become scarred, reducing the effectiveness of the new seal.

4. Using a screwdriver and hammer, tap out the stationary portion of the mechanical seal from both the front chamber plate and the motor side of the rear chamber plate.

#### **NOTE**

The seal will be damaged by removal. A new seal must be used when pump is reassembled.

In the case of a severe pump leak, inspect the shaft/bearing assembly for possible contamination

### Clean-Up Of Pump Housing

The process for cleaning up the pump housing is the same as the standard pump. See the "Clean Up of Pump Housing" section for further instructions.

### Bearing Removal

The bearing removal process for wet seal pumps is identical to the standard pump. See the "Bearing Removal" section for the standard pump for detailed instructions.

### Pump Assembly

1. Using water as a lubricant, install the stationary halves of the mechanical seal into the seal flange on the front and rear chamber plates. Press it into place with your fingers (See Figure 1 & 2). Then clean the stationary and rotary portion of the seal.

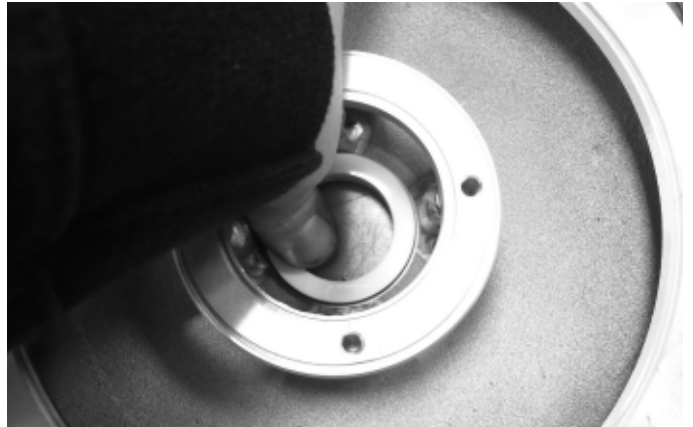

Figure 1

2. Assemble the rear chamber plate onto the pedestal, taking care to avoid hitting the mechanical seal on the pump shaft (Figure 3). The sight glass on the back chamber plate should be oriented so that it is positioned at the top of the pump (Figure 4).

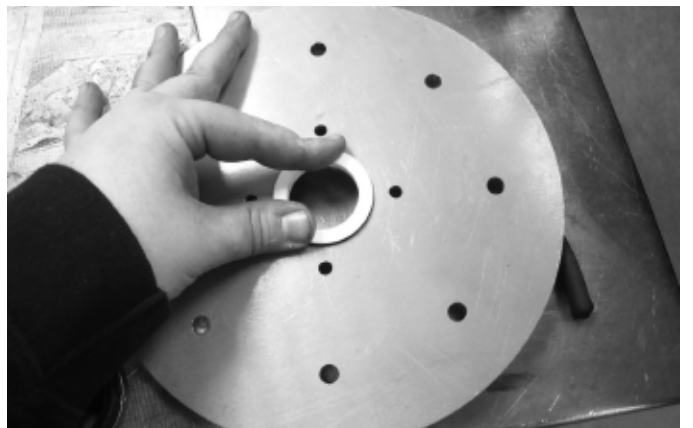

Figure 2



Figure 3

## Repair Instructions (9307CWS Series Only) - cont'd.

3. Install the rear rotary portion of the mechanical seal onto the pump shaft, using the provided seal tool and water as a lubricant (Figure 5).



**Figure 4**

4. Place the seal spring onto the rotary portion of the seal (Figure 6).



**Figure 5**

5. Install the o-ring into the groove on the rear chamber plate (Figure 7).

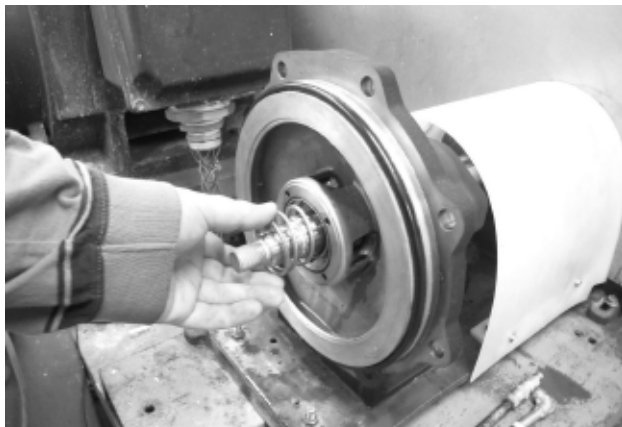

**Figure 6**

6. Place the membrane into the grooves (Figure 8) on the seal flange, then place the front chamber plate onto the shaft. Use the provided tool to push the front chamber plate so that it is up against the rear chamber plate (Figure 9). Screw in four Allen bolts while someone holds the front chamber plate in place with the provided tool. Torque the bolts to 48 in-lbs.

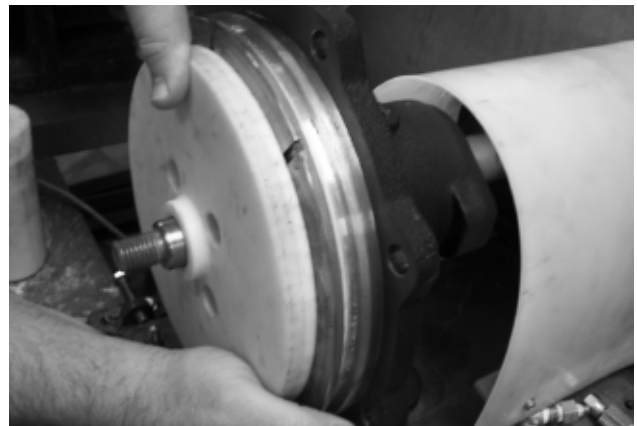

**Figure 7**



**Figure 8**

7. Before installing the impeller, make sure to remove the tool used to push the front chamber plate. Place the impeller, washer and acorn nut onto the pump shaft (Figure 10). Torque to 80 ft-lbs. using a 1-1/16" socket.



**Figure 9**

## Repair Instructions (9307CWS Series Only) - cont'd.

8. Install the o-ring in the pump casing; lubricate the o-ring with soap and water (Figure 11). Place the pump casing on the mounting flange (Figure 12). Torque the 8 bolts (Figure 12), which hold the casing to the mounting flange, to 75 ft-lbs. using a 3/4" wrench.



Figure 10



Figure 11

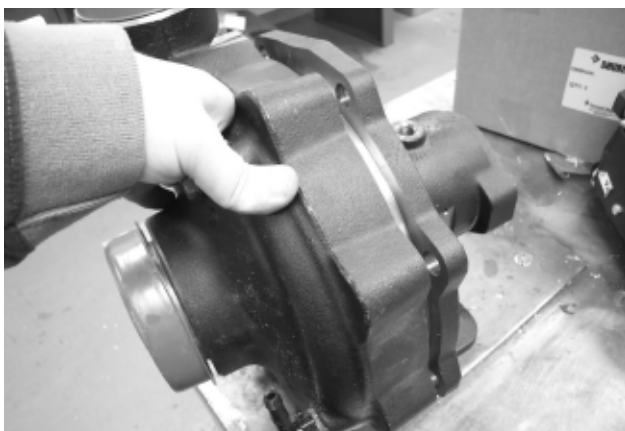

Figure 12



Figure 13

9. Add Hypro wet seal fluid to the chamber until the fluid comes to the top mark on the sight glass. Torque the screw to 45 in-lbs.

## Limited Warranty on Hypro/SHURflo Agricultural Pumps & Accessories

Hypro/SHURflo (hereafter, "Hypro") agricultural products are warranted to be free of defects in material and workmanship under normal use for the time periods listed below, with proof of purchase.

- Pumps: one (1) year from the date of manufacture, or one (1) year of use. This limited warranty will not exceed two (2) years, in any event.
- Pumps with ForceField™ Technology: one (1) year on all components, including seals.
- Accessories: ninety (90) days of use.

This limited warranty will not apply to products that were improperly installed, misapplied, damaged, altered, or incompatible with fluids or components not manufactured by Hypro. All warranty considerations are governed by Hypro's written return policy.

Hypro's obligation under this limited warranty policy is limited to the repair or replacement of the product. All returns will be tested per Hypro's factory criteria. Products found not defective (under the terms of this limited warranty) are subject to charges paid by the returnee for the testing and packaging of "tested good" non-warranty returns.

No credit or labor allowances will be given for products returned as defective. Warranty replacement will be shipped on a freight allowed basis. Hypro reserves the right to choose the method of transportation.

This limited warranty is in lieu of all other warranties, expressed or implied, and no other person is authorized to give any other warranty or assume obligation or liability on Hypro's behalf. Hypro shall not be liable for any labor, damage or other expense, nor shall Hypro be liable for any indirect, incidental or consequential damages of any kind incurred by the reason of the use or sale of any defective product. This limited warranty covers agricultural products distributed within the United States of America. Other world market areas should consult with the actual distributor for any deviation from this document.

### Return Procedures

All products must be flushed of any chemical (ref. OSHA section 1910.1200 (d) (e) (f) (g) (h)) and hazardous chemicals must be labeled/tagged before being shipped\* to Hypro for service or warranty consideration. Hypro reserves the right to request a Material Safety Data Sheet from the returnee for any pump/product it deems necessary. Hypro reserves the right to "disposition as scrap" products returned which contain unknown fluids. Hypro reserves the right to charge the returnee for any and all costs incurred for chemical testing, and proper disposal of components containing unknown fluids. Hypro requests this in order to protect the environment and personnel from the hazards of handling unknown fluids.

Be prepared to give Hypro full details of the problem, including the model number, date of purchase, and from whom you purchased your product. Hypro may request additional information, and may require a sketch to illustrate the problem.

**Contact Hypro Service Department at 800-468-3428 to receive a Return Merchandise Authorization number (RMA#).** Returns are to be shipped with the RMA number clearly marked on the outside of the package. Hypro shall not be liable for freight damage incurred during shipping. Please package all returns carefully. All products returned for warranty work should be sent **shipping charges prepaid** to:

HYPRO / PENTAIR  
Attention: Service Department  
375 Fifth Avenue NW  
New Brighton, MN 55112

For technical or application assistance, call the **Hypro Technical/Application number: 800-445-8360**, or send an email to: **technical@hypropumps.com**. To obtain service or warranty assistance, call the **Hypro Service and Warranty number: 800-468-3428**; or send a fax to the **Hypro Service and Warranty FAX: 651-766-6618**.

\*Carriers, including U.S.P.S., airlines, UPS, ground freight, etc., require specific identification of any hazardous material being shipped. Failure to do so may result in a substantial fine and/or prison term. Check with your shipping company for specific instructions.

