

# Hydra-Cell<sup>®</sup>

## Industrial Pumps

## Oil Cooler & Filter System

- *Ideal for high temperature applications*
- *Reduces pump operating oil temperature by 30° F (16.5° C) or more*
- *Extends oil life reducing the need for oil changes*
- *Extends bearing life*
- *Complete packaged system includes all fittings, hoses and adapters*

**NEW!**

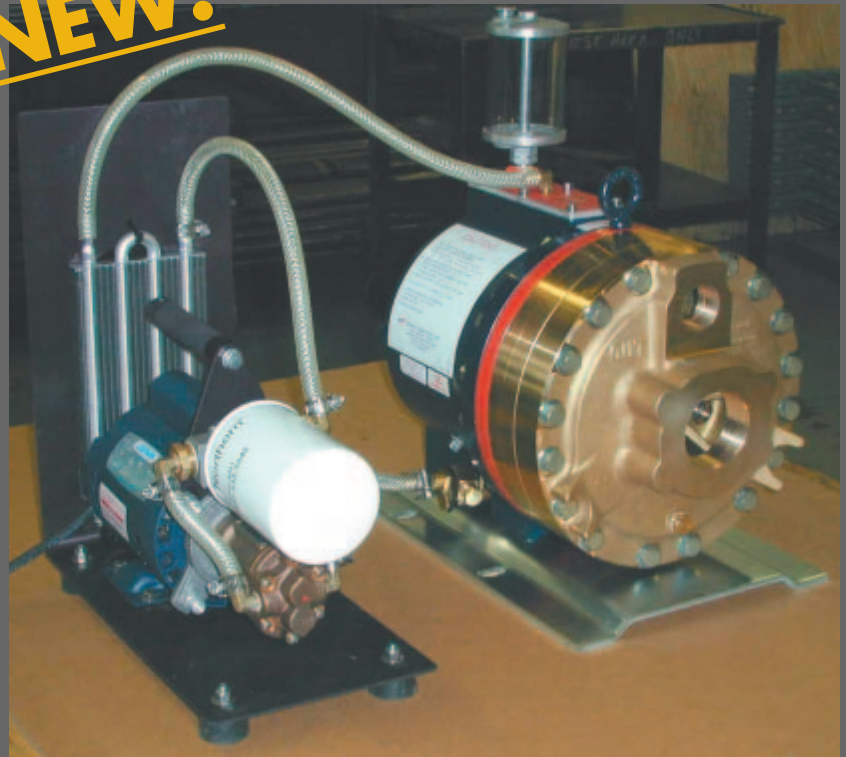

The Hydra-Cell Oil Cooler/Filtering system is designed to help Hydra-Cell pumps operate cooler in order to extend oil life and reduce bearing wear. Designed as a free standing, compact package, the system is easy to install and can be used with Wanner Hydra-Cell pumps including the D-35 pump shown here.



**WANNER ENGINEERING INC**

# Hydra-Cell®

**SIMPLY BUILT TO LAST**

# Oil Cooler & Filter System

When we say "Simply Built to Last", we mean it! Wanner Engineering Hydra-Cell pumps with the Oil Level Monitor Kit provide maximum performance and reliability in some of the toughest industrial equipment and processes:

- Hot fluids
- Reclaim water
- Corrosive fluids
- Slurries
- Abrasives
- Liquid gases
- Wetable powders
- Fertilizers
- Cutting fluids
- Viscous fluids
- Ultrapure fluids
- Chemicals
- Adhesives
- Soap solutions
- Salt water
- and many more...

### Specialized Design.

The Oil Cooler/Filtering System is designed to dramatically reduce the impact of high pumping fluid temperatures. The typical reduction of 30°F (16.5°C) achieved by the system dramatically extends bearing life. Having an oil filtration system built into the cooling loop also reduces wear and extends oil life.

The packaged system includes all necessary fittings, hoses, adapters and hardware and mounting materials to install the oil cooler and filtering system. The system requires 115 VAC, 50/60 Hz power input.

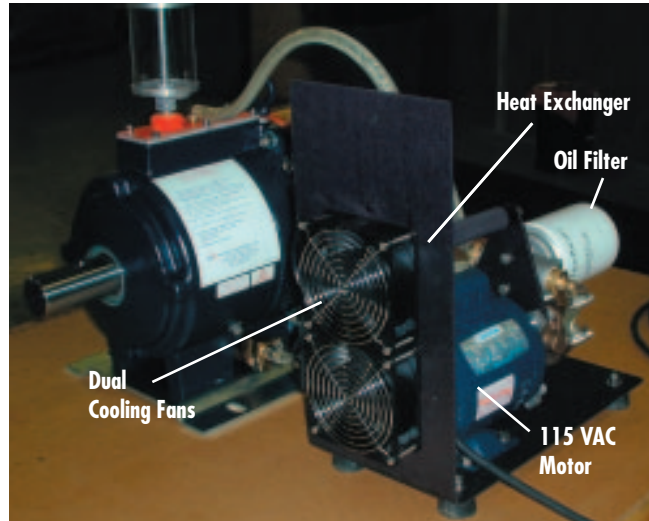

<b>Part Number</b>	103-100
--------------------	---------

### Dimensions in (mm)

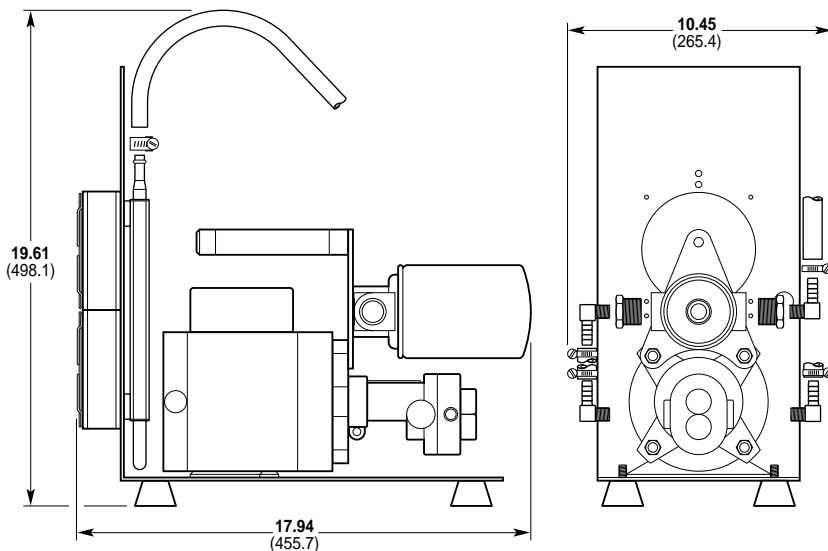

### Wanner Engineering, Inc.

1204 Chestnut Avenue, Minneapolis, MN 55403 USA  
 (612) 332-5681 FAX (612) 332-6937  
 Toll Free FAX (USA only) (800) 332-6812  
 Email: sales@wannereng.com  
 Website: www.hydra-cell.com  
 Document Fax Back System: (510) 745-0440



### Wanner International Ltd.

Grange Court, Grange Road  
 Tongham, Surrey GU10 1DW, England  
 Tel +44 (0) 1252 781234  
 FAX Tel +44 (0) 1252 781235  
 Email: sales@wannerint.com